

KITO

+

ER2 Series Electric Chain Hoist (125kg to 5t)

Owner's Manual

Hook Suspended Type (hoist only) : ER2

Motorized Trolley Type : ER2M

Manual Trolley Type : ER2SP/ER2SG

+

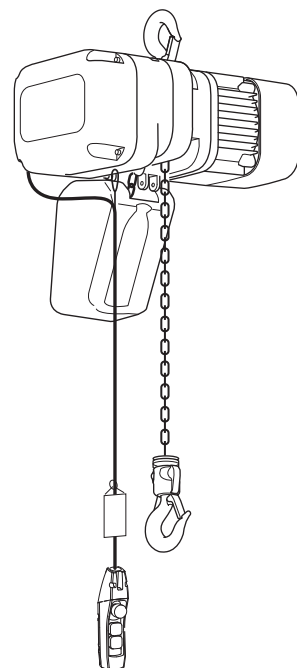

To Customer

+

- Thank you for purchasing KITO Electric Chain Hoist (ER2).
- Operators and maintenance engineers are requested to read this manual.
After reading, please keep this manual at hand for future use.
- This product is designed considering the environment protection. The product contains none of six hazardous substances specified by European RoHS Directives nor asbestos.

Table of Contents

Introduction.....	2
Safety Precautions	4
Chapter 1 Handling the Product.....	7
Chapter 2 Inspection	63
Chapter 3 Troubleshooting.....	95
Appendix	121
Warranty	150

Introduction

This electric chain hoist ER2 is designed and manufactured for the purpose to lift and lower a load within a normal work environment. The motorized trolley MR2 and the manual trolley are designed and manufactured for the purpose to move the lifted load laterally with the combination with the electric chain hoist.

Movement of a load in a 3D direction such as up/down, forward/backward and right/left is also enabled by combining with a crane.

This Owner's Manual is intended for those operating the KITO electric chain hoist ER2 and maintenance engineers (* personnel with expertise).

Other than this manual, Disassembly/Reassembly Manual and Parts List are also available for the maintenance engineers. Assign the maintenance engineers and use these materials for inspection and repair. Please contact the nearest distributor or KITO for these materials.

*Personnel having expertise in the structure and mechanism of electric chain hoists and being determined to be eligible for that by the business entity.

■ Disclaimer

- KITO shall not be liable for any damage incurred thereof due to natural disaster such as fire, earth quake and thunderbolt, conduct by third party, accident, willful conduct or negligence by customer, erroneous use and other use exceeding the operational condition.
- KITO shall not be liable for any incidental damage due to the use or non-use of the product such as the loss of business profit, suspension of business and damage of the lifted load.
- KITO shall not be liable for any damage arising from negligence of the contents in the Owner's Manual and the use of the product exceeding the scope of its specification.
- KITO shall not be liable for any damage arising from the malfunction due to the combination of the product with other devices in which KITO is not concerned.
- KITO shall not be liable to supply the spare parts for the product for which it has passed for 15 years since the discontinue of the product.

■ Restriction on Use

- The product described herein is not designed or manufactured for transporting people. Do not use the product for that purpose.
- The product described herein is designed for the materials handling work such as lifting/lowering and traveling the load under ordinary operational condition. Do not use the product for the work other than materials handling work.
- Do not assemble the product into machinery not for materials handling, as a part of it.

■ Operators

- Read carefully this Owner's Manual and the instruction manuals of related products, fully understand their contents, and the use and operate the product.
- Be sure to wear the proper clothing and protective equipment when using and operating the product.

Safety Precautions

Improper use of electric chain hoist causes danger such as drop of lifted load. Read this Owner's Manual carefully before installation, operation and maintenance. Use the product after understanding the product knowledge, safety information and precautions.

This Owner's Manual classifies the safety information and precautions into three categories of "DANGER" "WARNING" and "CAUTION".

Also read the instruction manual of the device associated with electric chain hoist, and follow the described contents.

Description of Signal Words



DANGER

Indicates an imminently hazardous situation which, if not avoided, will result in death or serious injury.



WARNING

Indicates a potentially hazardous situation which, if not avoided, could result in death or serious injury.



CAUTION

Indicates a potentially hazardous situation which, if not avoided, may result in minor or moderate injury. It may also be used to alert against unsafe practices.

Further, the event described in CAUTION may result in serious accident depending on the situation. All three categories describe important contents. Please follow the instruction.

After reading, please keep this manual at hand for future use by the user.

Description of Safety Symbols



Means "Prohibited" or "You must not do".

Prohibited action is shown in the circle or described near the circle.

Prohibited

This Owner's Manual uses  as the general prohibition.



Means "Mandatory Action" or "You must do".

Required action is shown in the circle or described near the circle.

Mandatory

This Owner's Manual uses  as the general instruction.

General Matters on Handling and Control

DANGER



Prohibited

- **This product shall not be disassembled and repaired by personnel other than maintenance engineers.**
Other than this manual, Disassembly/Assembly Manual and Parts List are provided for the maintenance engineers. Perform the disassembling and repair by the maintenance engineer in accordance with these materials for maintenance.
- **Do not modify the product and its accessories.**
Failure to comply with these instructions may result in death or serious injury.



Mandatory

- **Understand the contents of the Owner's Manual sufficiently. Then operate the Electric chain hoist.**
- **Connect properly according to the "Canadian Electrical Code (CEC) Part 1".**
- **Warning label is affixed to each part of the product. Follow the instruction described in the warning label.**
Failure to comply with these instructions may result in death or serious injury.

⚠ CAUTION



Prohibited

- **Do not drag or drop the product when carrying.**

Otherwise it causes damage or flaw of the electric chain hoist, bodily injury or loss of property due to the drop of the lifted load.



Mandatory

- **When discarding the product, disassemble it not to be used and discard in accordance with the ordinances of local government or the rules specified by the business entity.**

Ask the local government or the relevant section for the details.

Refer to "Disassembly/Assembly Manual" for disassembling, or contact KITO.

(This product uses oil. We prepare SDS (Safety Data Sheet) for the oil. Contact KITO for it.)

- **Carry out daily inspection by user.**
- **Carry out inspection (monthly, annual) by maintenance engineer.**
- **Keep the record of the inspection.**

Failure to comply with these instructions causes bodily injury or loss of property.

■ General Matters on Handling of Dual Speed VFD Model

The dual speed VFD model electric chain hoist is controlled by VFD for important items related to safety such as operation, braking and emergency stop. Be sure to follow the safety precautions below as well as the above safety precautions.

⚠ DANGER



Prohibited

- **Do not change parameters.**

When parameters need to be changed, ask distributor or KITO.

- **Do not carry out the work such as maintenance and inspection within 5 minutes after power off.**

Wait for the completion of discharging of the capacitor inside the VFD.

- **Do not touch the controller cover as it becomes hot during operation.**

Do not touch the controller cover until about 30 minutes elapsed after the stop of operation.

- **USE KITO genuine VFD.**

The VFD requires the special specification for KITO. Be sure to use genuine VFD.

- **Do not change the connection of the VFD.**

When the wires were removed for any reason, connect them again correctly checking the wiring diagram inside the controller cover.

- **Do not carry out withstand voltage test and insulation resistance measurement of a circuit by megger while the VFD is connected.**

- **Do not turn off the power while operating.**

Failure to comply with these instructions may result in death or serious injury and the damage of VFD.

Chapter 1

Handling the Product

This chapter describes mainly how to use, assemble and install, and the check after installation. It also describes the daily inspection items before use.

● For Operators and Maintenance Engineers

Type and Names of Each Part	8
Opening the Package	11
Product Specification and Operational Environment	16
How to Use	19
● How to Operate the Push Button Switches	20
● Operation	23
● Speed Change of Dual Speed VFD Model	26
● How to Sling the Load Properly	26
● How to Suppress the Swinging of a Load	26
● Precautions After Work	27
Daily Inspection	28
● Electric Chain Hoist.....	28
● Motorized Trolley	33
● Manual Trolley	34

● For Maintenance Engineers and Installars

Work Flow of Assembling and Installation.....	36
Assembling	37
● Assembling Parts to Electric Chain Hoist	37
● Combination with the Trolley.....	41
● Checking Power and Power Cable	52
● Connecting Cables	54
Installation.....	57
● Connecting Power and Power cable.....	57
● Installing the Hook suspended Type (hoist only).....	57
● Installing the Trolley Combined Model.....	58
Check after Installation	61

Type and Names of Each Part

■ Hook Suspended Type (ER2)

- Electric chain hoist dedicated for elevation

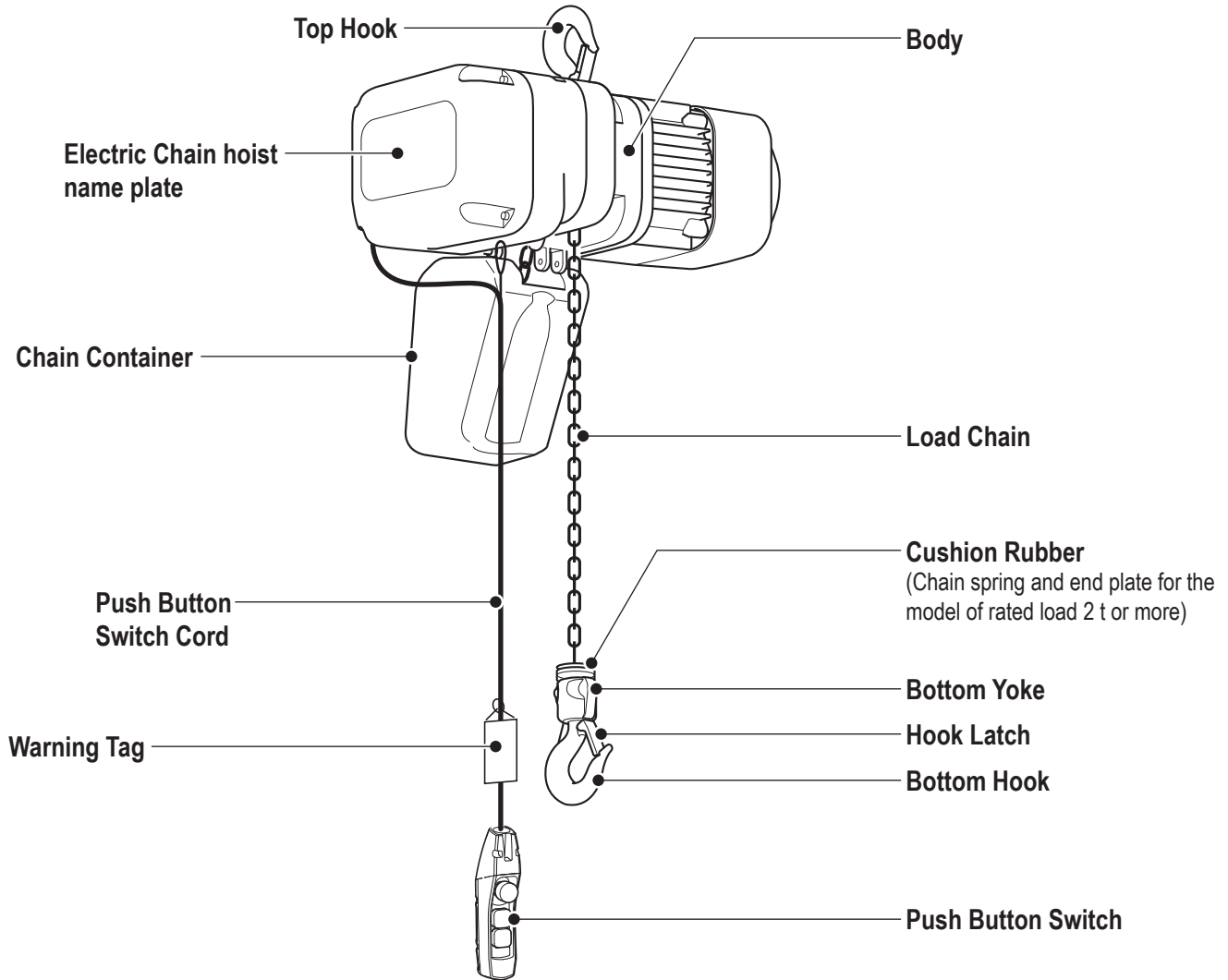

! DANGER



Mandatory

- Warning labels are affixed to each part other than above. Be sure to follow the instructions in the label. Failure to comply with the contents of the label may result in death or serious injury.

Motorized Trolley Type (ER2M)

- Electric Chain Hoist combined with motorized trolley (MR2) for elevation and traveling motion

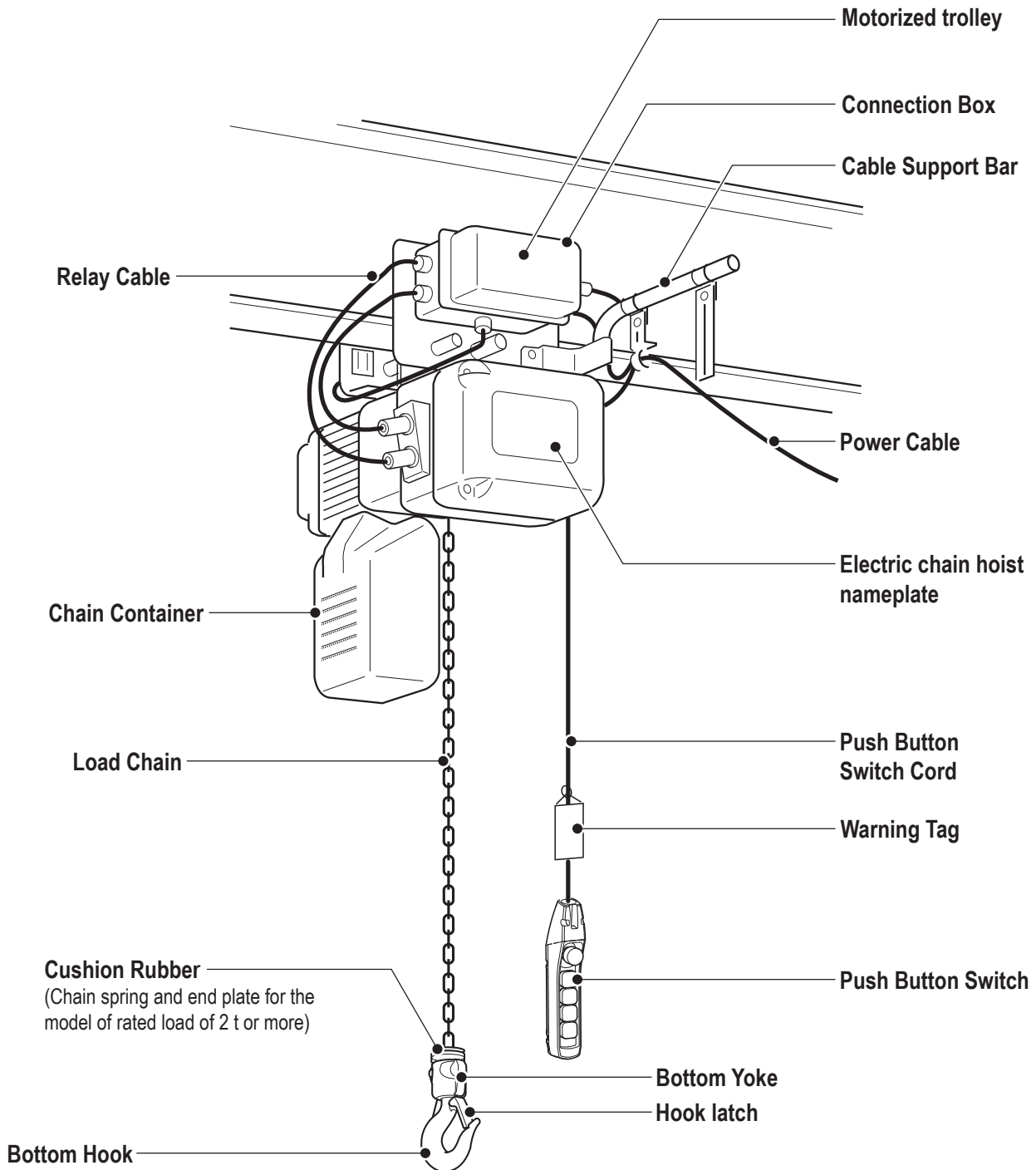

DANGER



Mandatory

- Warning labels are affixed to each part other than above. Be sure to follow the instructions in the label. Failure to comply with the contents of the label can result in serious bodily injury or death.

(to be continued)

Type and Names of Each Part (continued)

Manual Trolley Type (ER2SG/ER2SP)

- ER2SG : The electric chain hoist equipped with the geared trolley (TSG) enabling fine adjustable lateral motion of the load by pulling the hand chain.
- ER2SP : The electric chain hoist equipped with the plain trolley (TSP) enabling lateral motion by moving the load manually. For light work.

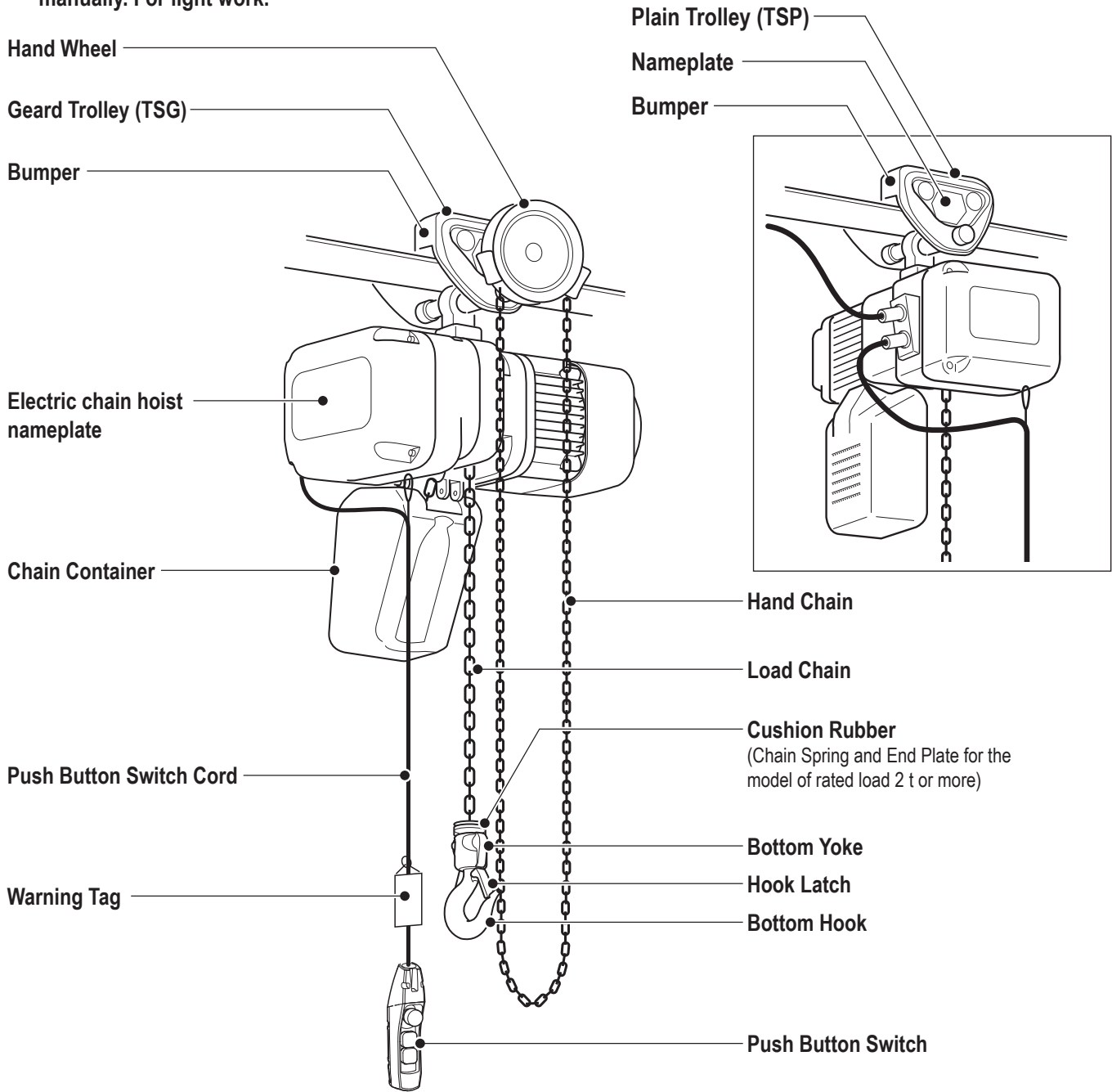

! DANGER



Mandatory

- Warning labels are affixed to each part other than above. Be sure to follow the instructions in the label. Failure to comply with the contents of the label can result in serious bodily injury or death.

Opening the Package

■ Checking the Product

- Make sure that the indication on the package and the product coincide with your order.
- Make sure that the product is not deformed and damaged due to the accident during transportation.

■ Packaging

■ Packaging

For the customer's convenience, the main parts of our product are packaged individually and delivered.

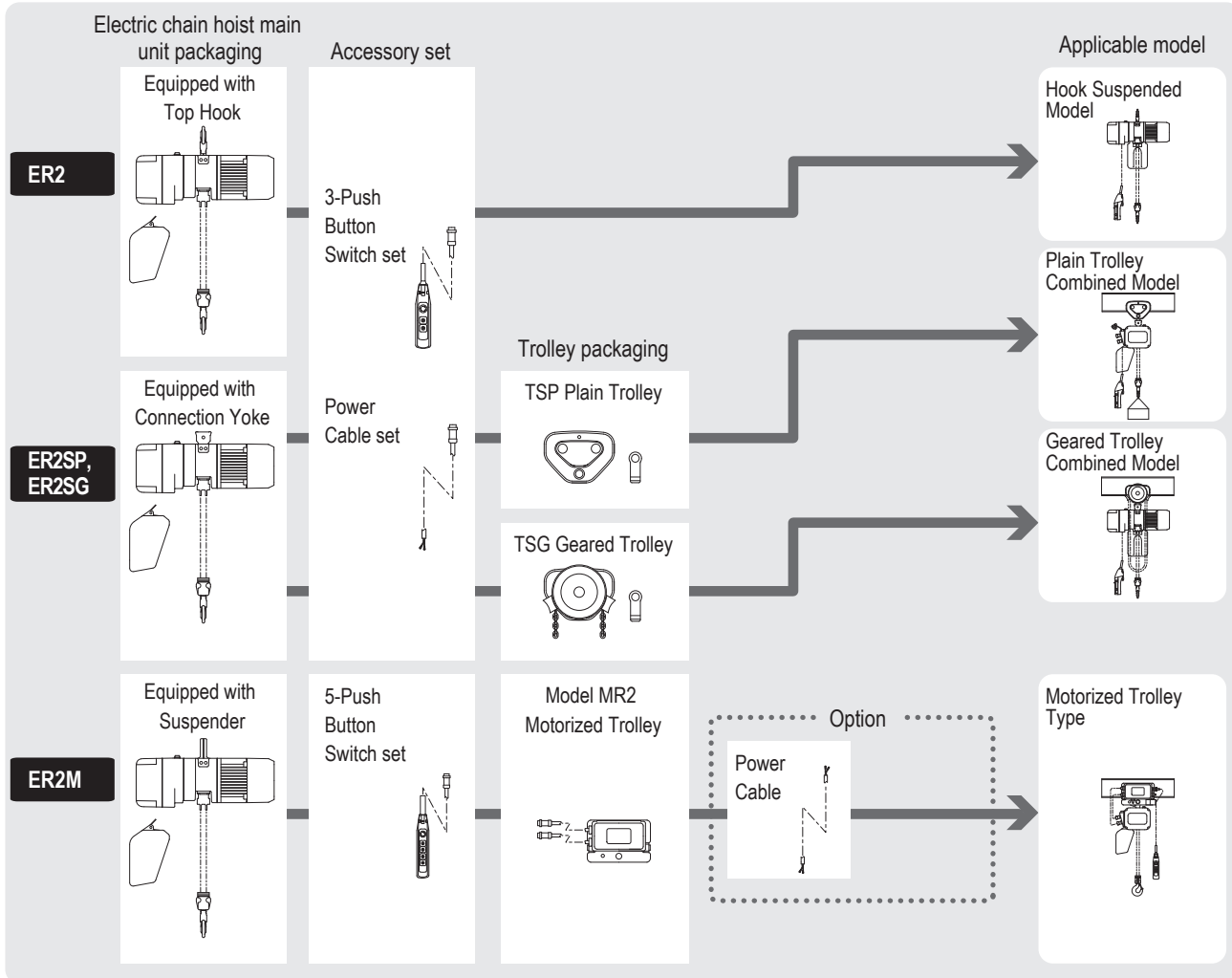

* Power Cable longer than 10 m is available as an optional part.

■ Parts packaged with the Electric Chain Hoist

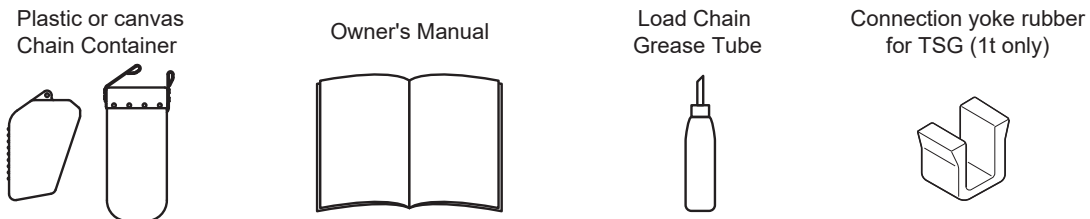

Note: End suspender is attached if Chain Container is not ordered. (Excludes double chain type)

(to be continued)

Opening the Package (continued)

■ Nameplate and Product Model

■ Nameplate Indication of Electric Chain Hoist

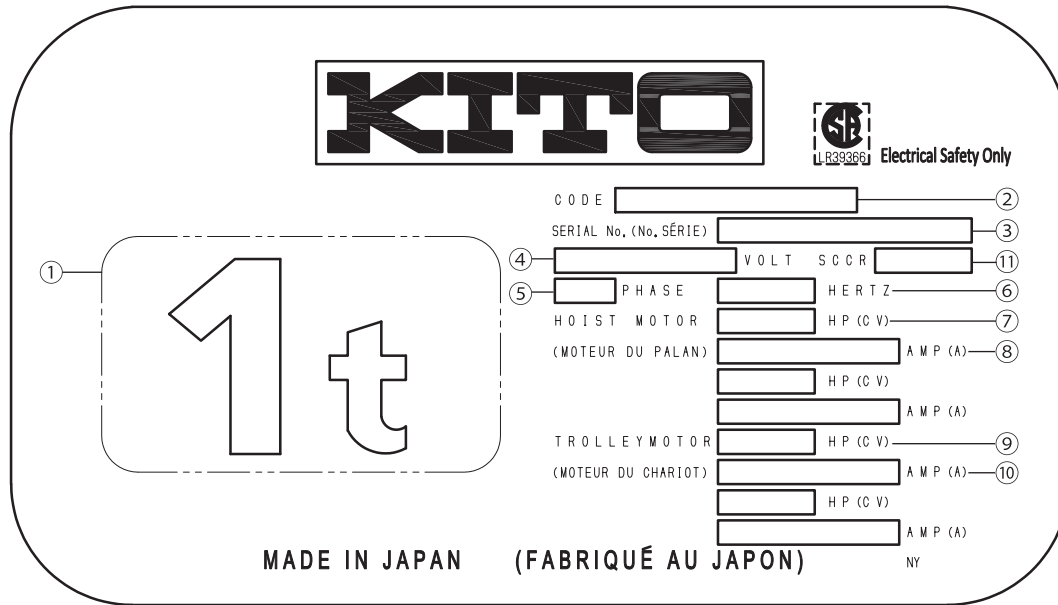

1 [] Capacity Ex. 1t, 500kg

The maximum mass of the load that can be imposed on the product. The mass of the hook is excluded.

2 CODE...Product model Ex. ER2-005S

A code to indicate the model No. of the product, capacity and lifting speed.

3 SERIAL No.

Serial number to indicate the manufacturing sequence of the product.

4 Rated Voltage

5 Number of Phase

6 Frequency

7 Hoist motor output

8 Rated hoist motor current

9 Trolley motor output

10 Rated trolley motor current

11 SCCR (Short circuit current rating)

■ Code of ER2

Capacity	Body	CODE			
		Single speed model		Dual speed model	
		Standard speed	Low speed	Standard speed	Low speed
125kg	ER2-B	—	(ER2-001H)*	—	(ER2-001H/HD)*
250kg		ER2-003S	—	ER2-003IS/SD	—
500kg	ER2-C	ER2-005S	ER2-005L	ER2-005IS/SD	ER2-005IL/LD
1t	ER2-D	ER2-010S	ER2-010L	ER2-010IS/SD	ER2-010IL/LD
1.5t	ER2-E	ER2-015S	—	ER2-015IS/SD	—
2t	ER2-E	ER2-020S	ER2-020L	ER2-020IS/SD	ER2-020IL/LD
2.5t	ER2-F	ER2-025S	—	ER2-025IS/SD	—
3t	ER2-E	ER2-030S	—	ER2-030IS/SD	—
5t	ER2-F	ER2-050S	—	ER2-050IS/SD	—

* High Speed Type

■ Code of MR2

Capacity	CODE		
	Single speed model		Dual speed model
	Standard speed	Low speed	Standard speed
125kg	MR2-010S	MR2-010L	MR2-010IS/SD
250kg			
500kg			
1t			
1.5t	MR2-020S	MR2-020L	MR2-020IS/SD
2t			
2.5t	MR2-030S	MR2-030L	MR2-030IS/SD
3t			
5t	MR2-050S	MR2-050L	MR2-050IS/SD

Opening the Package (continued)

■ Nameplate Indication of Manual Trolley

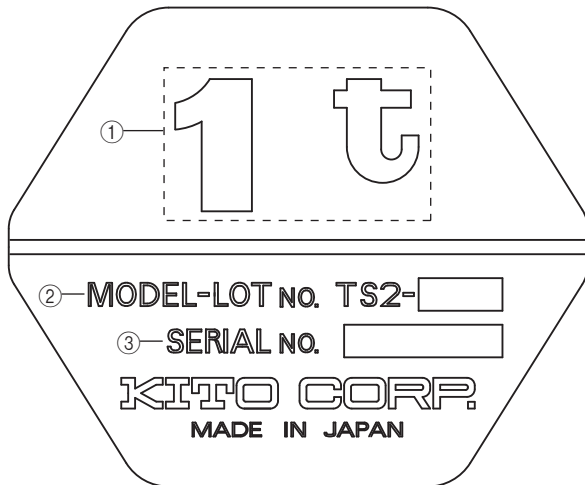

- 1 [] Capacity Ex. 1t, 500kg
The maximum mass of the load that can be imposed on the product. The mass of the hook is excluded.
- 2 LOT No.
Manufacture No. to identify the time of manufacture and the production lot.
- 3 SERIAL No.
Serial number to indicate the manufacturing sequence of the product.

■ Checking the Marks

⚠ DANGER



Mandatory

- Be sure to check that the Load Chain has 'RH-DAT' or 'FT-DAT' mark on it and the chain size is appropriate for the ER2 model you are using (See the following table.). The Load Chain of other models (such as model ES or ER) or different rating cannot be used.

Use of the Load Chain of other model or other rating may result in death or serious injury due to the drop of the lifted load.

Code	Load Chain size : diameter (mm)	Mark	Mark pitch
ER2-001H/IH/HD	4.3	FT-DAT	24 Links
ER2-003S/IS/SD			
ER2-005L/IL/LD	6.0	RH-DAT	20 Links
ER2-005S/IS/SD			
ER2-010L/IL/LD			
ER2-010S/IS/SD	7.7		16 Links
ER2-015S/IS/SD			
ER2-020L/IL/LD	10.2		12 Links
ER2-020S/IS/SD			
ER2-025S/IS/SD			
ER2-030S/IS/SD	10.2	16 Links	
ER2-050S/IS/SD	11.2	12 Links	

The mark (RH-DAT) to indicate the model of the Load Chain is indicated on it at an equal spacing. Make sure that the Load Chain is of a chain size (wire diameter) appropriate for ER2 referring to the table in the left.

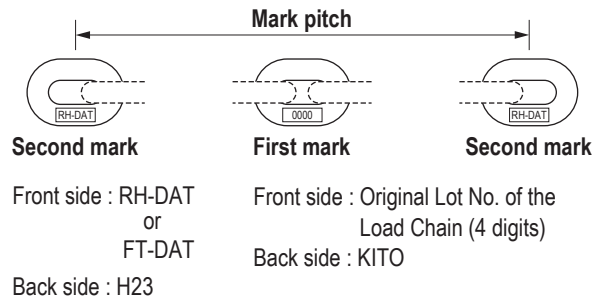

■ Recording the Product No.

- Fill in the table in the right with product's Lot No., Serial No. (described in the product nameplate), date of purchase and the name of the sales shop where you purchased the product.
- * When requesting repair or ordering a chain hoist part, please inform us of these pieces of information together.

Item	Electric chain hoist	Motorized trolley	Manual trolley
Lot No.			
Serial No.			
Date of purchase			
Name of the sales shop			

■ Recording the Initial Value

- When opening the package, fill in the table in the right with the opening dimension "a" between embossed marks on the Bottom Hook, the width of the hook "b" and the thickness of the hook "c". (These values are used for checking. Record the value for the top hook of ER2 when it is used individually.)

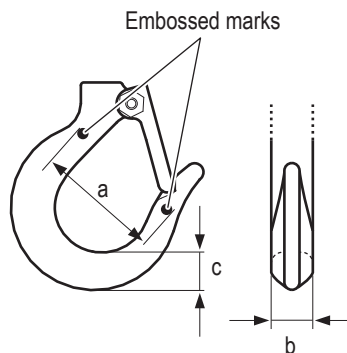

Dimensions when the package was opened

Top Hook (For ER2 only)	Dimension a	mm
	Dimension b	mm
	Dimension c	mm
Bottom Hook	Dimension a	mm
	Dimension b	mm
	Dimension c	mm

Product Specification and Operational Environment

The operational environment of the electric chain hoist and motorized trolley is as follows:

■ Standard Specification

- Short time ratings :ER2 series(Capacity 100 %) : Single speed model — 60 min.
Dual speed VFD model (high speed/low speed) — 30/10 min.
- :MR2 series(Capacity 100 %) : Single speed model — 30 min.
Dual speed VFD model (high speed/low speed) — 30/10 min.
- Intermittent ratings :ER2 series(63 % of the capacity) : Single speed model — 60 % ED (at 360 rev/h)
Dual speed VFD model (high speed/low speed) — 40/20 % ED
(120/240 rev/h)
- :MR2 series(63 % of the capacity) : Single speed model — 40 % ED (at 240 rev/h)
Dual speed VFD model (high speed/low speed) — 27/13 % ED (78/162 rev/h)
- Grade *1 :ISO-M6, M5 or M4, FEM-3m, 2m or 1Am, ASME-H4
- Protection :Hoist IP55, Push button IP65
- Operation Push button switch operation / 3-Push Button Switch set for hoist only and Manual trolley type / 5-Push Button Switch set for motorized trolley combined model
- Power supply method....Power supply through cabtyre cable
- Color.....KITO Yellow (Equivalent to Munsell 7.2YR6.5/14.5)
- Noise level :ER2, single speed 75dB or less (A scale: measured at 1 m away from the Electric chain hoist)
:ER2, dual speed VFD model 80dB or less (A scale: measured at 1 m away from the Electric chain hoist)
:MR2 85dB or less (A scale: measured at 1 m away from the Electric chain hoist)
- Braking capacity :150% of the capacity or more
- Other.....Power Cable length 5 m/10 m (Standard)

Product category	Motor Insulation Class	Voltage range		Operating Voltage
		50Hz	60Hz	
220/440V Class (230/460V Class)	B	/	208-230V	110V (110V~121V)
			415-460V	
500V Class	B	500V	575V	

NOTE

- Operate the electric chain hoist with the rated voltage.
- Do not use the electric chain hoist exceeding the short time ratings and the intermittent ratings.
- Suitable for use on a circuit capable of delivering not more than 5kA RMS symmetrical amperes, 575V maximum. (SCCR 5kA)

* Grade

Capacity (kg or t)	Code		GRADE			Code	GRADE		
	Single speed	Dual speed	ISO	ASME	FEM		Dual speed	ISO	ASME
125	ER2-001H	ER2-001HD	M5	H4	2m	ER2-001IH	M6	H4	3m
250	ER2-003S	ER2-003SD				ER2-003IS			
500	ER2-005L	ER2-005LD				ER2-005IL			
	ER2-005S	ER2-005SD				ER2-005IS			
1	ER2-010L	ER2-010IL/LD							
	ER2-010S	ER2-010IS/SD							
1.5	ER2-015S	ER2-015IS/SD							
2	ER2-020L	ER2-020IL/LD	M4	H4	1Am				
		ER2-020S							
2.5	ER2-025S	ER2-025IS/SD							
3	ER2-030S	ER2-030IS/SD							
5	ER2-050S	ER2-050IS/SD							

* For 125kg - 500kg dual speed VFD type equipped with friction clutch with mechanical brake, the grade is ISO M5 and FEM 2m.

• ISO

ISO 4301 specifies the total operating hour (service life) of gears and bearings according to the loading status. For example, the total operating hour (service life) of the mechanism when it is constantly applied with the capacity is 1,600 hours for M5. The total operating hour is 6,300 hours when operated with a medium load.

Loading status*	Total operating hour h					
	800	1600	3200	6300	12500	25000
Light				M4	M5	M6
Medium			M4	M5	M6	
Heavy		M4	M5	M6		
Ultra heavy	M4	M5	M6			

*** Rate of loading**

Light : A case where the capacity is rarely applied. Usually the hoist is used with a light load.

Medium: A case where the capacity is applied considerably frequently. Usually the hoist is used with a medium load.

Heavy : A case where the capacity is applied considerably frequently. Usually the hoist is used with a heavy load.

Ultra heavy : A case where the capacity is applied constantly.

• ASME HST

Hoist duty class	Typical areas of application	Operation time ratings at K=0.65			
		Uniformly distributed work periods		Infrequent work periods	
		Max. on time, min / hr	Max. No. starts / hr	Max. on time from cold start, min	Max. No. of starts
H2	Light machine shop fabricating, service, and maintenance; loads and utilization randomly distributed; capacities infrequently handled.	7.6 (12.5%)	75	15	100
H3	General machine shop fabricating, assembly, storage, and warehousing; loads and utilization randomly distributed.	15 (25%)	150	30	200
H4	High volume handling in steel warehouses, machine shops, fabricating plants and mills, and foundries; manual or automatic cycling operations in heat treating and plating; loads at or near capacity frequently handled.	30 (50%)	300	30	300

* The grade symbols are identical to those of ASME HST-1M. (Performance standard for Electric Chain Hoist)

• FEM

Relation between ISO-and FEM-Denominations

1 Dm	1 Cm	1 Bm	1 Am	2 m	3 m	4 m	5 m
M 1	M 2	M 3	M 4	M 5	M 6	M 7	M 8

Load spectrum	Cubic mean value	Class of operation time									
		V0.06	V0.02	V0.25	V0.5	V1	V2	V3	V4	V5	
		T0	T1	T2	T3	T4	T5	T6	T7	T8	
		Average operation time per day in hours									
		≤0.12	≤0.25	≤0.5	≤1	≤2	≤4	≤8	≤16	>16	
1 L1	K≤0.50	-	-	1 Dm	1 Cm	1 Bm	1 Am	2 m	3 m	4 m	
2 L2	0.50<K≤0.63	-	1 Dm	1 Cm	1 Bm	1 Am	2 m	3 m	4 m	5 m	
3 L3	0.63<K≤0.80	1 Dm	1 Cm	1 Bm	1 Am	2 m	3 m	4 m	5 m	-	
4 L4	0.80<K≤1.00	1 Cm	1 Bm	1 Am	2 m	3 m	4 m	5 m	-	-	

Class of operating time		Average operating time per day (in hours)	Calculated total operating time (in hours)
V0.06	T0	≤0.12	200
V0.12	T1	≤0.25	400
V0.25	T2	≤0.5	800
V0.5	T3	≤1	1,600
V1	T4	≤2	3,200
V2	T5	≤4	6,300
V3	T6	≤8	12,500
V4	T7	≤16	25,000
V5	T8	>16	50,000

* The grade symbols are identical to those of FEM 9.511.

(Rules for Design of Serial Lifting Equipment: Classification of Mechanisms)

(to be continued)

Product Specification and Operational Environment (continued)

■ Operational Environment

Ambient temperature	: -20°C to +40°C
Gradient of rail	: No gradient in travel rail (for the hoist with trolley)
Ambient humidity	: 85 % or less (no condensation)
Explosion-proof construction	: Not applicable to the work environment with explosive gases or explosive vapor
Non-conforming environment	: Places exposed to organic solvents
	: Places with high levels of general or combustible dust in the air
	: Places with high levels of acid or salt in the air
	: Places where oils are scattered or attached

NOTE

When installing the electric chain hoist outdoors or to the place where the hoist is exposed to direct rain, wind and snow, shade the hoist with roof to protect it from rain, wind and snow.

How to Use

ER2 Series Electric Chain Hoist has two models: single speed model and dual speed VFD model. Other than them, such products are provided that can travel/traverse when combined with a trolley or a crane. Their push button switches for operation differ in the size and the operating method. Check the product model of the hoist and use it properly.

DANGER



Prohibited

- Do not use the Hook without a Hook Latch or damaged Hook.
- Do not use the Load Chain with heavy elongation, abrasion or deformation.
- Do not cut, extend, or weld the Load Chain.
- Do not use the Load Chain with the Bottom Hook without smooth motion.
- Do not use the Load Chain when its brake does not function securely even without load, or when the stopping distance is too long.
- Do not use the product if it moves oppositely to the direction indicated on the push button switch.

Failure to comply with these instructions may result in death or serious injury.



Mandatory

- Carry out daily inspection before operation.
(When any abnormality was found during inspection, turn off the power, indicate "FAILURE" and ask the maintenance engineer for repair.)
- Check the slinging devices for no abnormality.
Failure to comply with these instructions may result in death or serious injury.

CAUTION



Prohibited

- Do not use the product with an illegible nameplate or warning label affixed to the body.

Failure to this instruction may result in the injury or the property damage.



Mandatory

- When using the product for the first time, affix the labels indicating East, West, North and South on the push button switches.
- Check the contents of the work and make sure that the electric chain hoist has proper performance for the load and lift.
- Check the contents of the work and operate the electric chain hoist at a place enabling to look out the operating area without hindrance.
- When looking out the operating area is difficult, arrange the monitor near the place for safety.
- Operate the electric chain hoist at a place with firm foothold without danger of falling, stumbling, slipping or over turning.
- Before moving the load, warn all the surrounding people.
- Even if the crane or the electric chain hoist is permanently installed and used for the same purpose repeatedly, check the contents of the work and make sure that the work does not exceed the capacity on each occasion.
- Appoint the maintenance engineer or competent personnel among the qualified personnel for operation of cranes and electric chain hoists. Indicate the name of the personnel on a place with legibility.
- The maintenance engineers shall check the result of daily inspection.
- When informed of abnormality of the electric chain hoist, the maintenance engineers shall take immediately any necessary measures such as prohibition of use and repair.
- When carrying out inspection and repair, secure the environment for safe work without electric shock and falling.

Failure to comply with these instructions may result in bodily injury or property damage.

How to use (continued)

How to Operate the Push Button Switches

⚠ CAUTION



Prohibited

- Do not hang the Push Button Switch Cord on other object, or pull the cord strongly.
- Do not use the Push Button Switch if its button does not operate smoothly.
- Do not bundle or tie the cord for the adjustment of its length.

Failure to comply with this instruction causes bodily injury or loss of property.



Mandatory

- When taking hand off the Push Button Switch after operation, do not throw it. Be careful not to hit other worker with the Push Button Switch.
- When starting operation of the hoist after stopping the hoist by pushing the Emergency Stop Button, be sure to confirm there are no hazards around the workplace before releasing the lock of the Emergency Stop Button and starting operation.

Failure to comply with this instruction causes bodily injury or loss of property.

NOTE

If the Electric chain hoist is tripped due to overheat of the VFD, the VFD cannot be reset soon after the trip. Reset the VFD after a while.

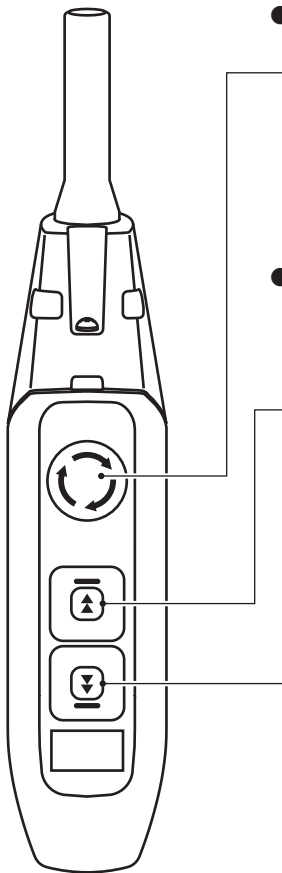

3-Push Button Switch Set

3-Push Button Switch Set is equipped with a lock type emergency stop button (VFD reset button) and lift/lower push buttons. One-step push button switch or two-step push button switch is mounted as Lift/lower push button switches in accordance with the specification of single speed or dual speed VFD specification. Refer to the operation method of the corresponding specification.



● Emergency Stop Button (VFD Reset Button)













- 1) Press the Emergency Stop Button  deeply when carrying out an emergency stop or VFD reset.
 - The button is locked at the pressed end.
- 2) Turn the Emergency Stop Button  clockwise to cancel the lock.
 - Press-locked button returns to the original position.

* When the electric chain hoist is not used, press the Emergency Stop Button  deeply to the end.

● Operation Button

● Lift/Lower Button

	Single Speed Model		Dual Speed VFD Model
	<ol style="list-style-type: none"> 1) Press  button to lift the load. <ul style="list-style-type: none"> • The electric chain hoist stops when the button is released. 		<ol style="list-style-type: none"> 1) Press  button to lift the load. 2) When lifting the load at high speed, press the  button further to the end. <ul style="list-style-type: none"> • The electric chain hoist stops when the button is released.
	<ol style="list-style-type: none"> 1) Press  button to lower the load. <ul style="list-style-type: none"> • The electric chain hoist stops when the button is released. 		<ol style="list-style-type: none"> 1) Press  button to lower the load. 2) When lowering the load at high speed, press the  button further to the end. <ul style="list-style-type: none"> • The electric chain hoist stops when the button is released.



5-Push Button Switch Set

5-Push Button Switch Set is equipped with a lock type emergency stop button (VFD reset button) and lift/lower push buttons. One-step push button switch or two-step push button switch is mounted as Lift/lower push button switches in accordance with the specification of single speed or dual speed VFD specification. Refer to the operation method of the corresponding specification.

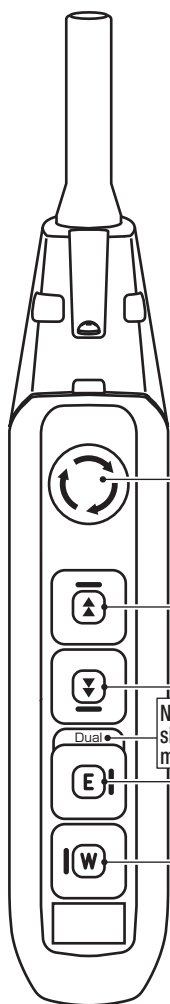
Moving direction of the trolley is expressed as East/West for traveling motion in the operational instruction of the Push Button Switch Set.











● Emergency Stop Button (VFD Reset Button)









- 1) Press the Emergency Stop Button  deeply when carrying out an emergency stop or VFD reset.
 - The button is locked at the pressed end.
 - 2) Turn the Emergency Stop Button  clockwise to cancel the lock.
 - Press-locked button returns to the original position.
- * When the electric chain hoist is not used, press the Emergency Stop Button  deeply to the end.

● Operation Button

● Lift/Lower Button

	Single Speed Model	Dual Speed VFD Model
	1) Press  button to lift the load. <ul style="list-style-type: none"> • The electric chain hoist stops when the button is released. 	1) Press  button to lift the load. 2) When lifting the load at high speed, press the  button further to the end. <ul style="list-style-type: none"> • The electric chain hoist stops when the button is released.
	1) Press  button to lower the load. <ul style="list-style-type: none"> • The electric chain hoist stops when the button is released. 	1) Press  button to lower the load. 2) When lowering the load at high speed, press the  button further to the end. <ul style="list-style-type: none"> • The electric chain hoist stops when the button is released.

● Travel Button

	Single Speed Model	Dual Speed VFD Model
	1) Press  button to move the trolley to the east. <ul style="list-style-type: none"> • The trolley stops when the button is released. 	1) Press  button to move the trolley to the east at low speed. 2) Press  button further to the end to move the trolley to the east at high speed. <ul style="list-style-type: none"> • The trolley stops when the button is released.
	1) Press  button to move the trolley to the west. <ul style="list-style-type: none"> • The trolley stops when the button is released. 	1) Press  button to move the trolley to the west at low speed. 2) Press  button further to the end to move the trolley to the west at high speed. <ul style="list-style-type: none"> • The trolley stops when the button is released.

No label for the single speed model

<Memo>

A series of horizontal dotted lines forming a ruled area for writing a memo. The lines are evenly spaced and extend across the width of the page.

Operation

General

DANGER



Prohibited

- Do not operate the electric chain hoist in an environment with flammable or explosive gas. The electric chain hoist is not designed as explosion proof specification.
- Do not use the electric chain hoist exceeding the ratings (short period rating, intermittent rating) of the lifting motor and the maximum start-up frequency.
- Do not use the electric chain hoist by the voltage other than the rated voltage.
- Do not use the Emergency Stop Button for ordinary stop operation.
- Do not expose the Load Chain to sparks from welding.
- Do not contact welding rods or electrodes with the Load Chain.
- Do not use the Load Chain as the earth for welding work. (Fig. A)

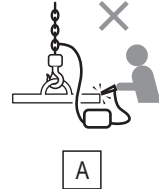

Failure to comply with these instructions may result in death or serious injury.



Mandatory

- Follow the operating environment and conditions for the electric chain hoist.

Failure to comply with this instruction may result in death or serious injury.

Slinging

DANGER



Prohibited

- Do not apply a load to the tip of the Bottom Hook or the Hook Latch. (Fig. B)
- Do not bind a load with the Load Chain directly. (Fig. C)
- Do not operate the Load Chain while it is in contact with any sharp edges. (Fig. D)

Failure to comply with these instructions may result in death or serious injury.

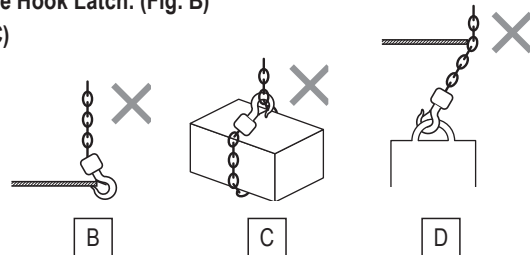

Mandatory

- Use the sling appropriate for the weight and shape of a load. Inappropriate slinging may result in danger such as drop of a lifted load.
- Carry out the slinging with equal load on slinging devices for stable lifting of a load.
- Attach the slinging devices securely to a load.
- Attach the slinging devices to the Bottom Hook correctly.

Failure to comply with these instructions may result in death or serious injury.

(to be continued)

How to use (continued)

■ Lifting/Lowering

⚠ DANGER



Prohibited

- **Do not lift more than the capacity. (Fig. E)**
The capacity is indicated in the nameplate.
- **Do not operate the electric chain hoist exceeding the lifting height.**
- **Do not dare to lift the structure or any other object supposed to be difficult to lift.**
- **Do not lift a load at no-load side of the Load Chain.**
- **Do not stop the electric chain hoist with the limit switch (over winding prevention device).**
- **Do not use the electric chain hoist when the Friction Clutch (overload prevention device) is operated to stop winding.**
- **Do not lift or lower excessively.**
 - Do not remove the Chain Spring or the Cushion Rubber to operate the limit switch by hitting the body with the Bottom Hook. If such stop operation is repeated, it may result in breaking of the Load Chain.
 - Do not hit the body with the End Stopper of the Load Chain to cause the operation of the Friction Clutch. If such operation is repeated, it may result in breaking of the Load Chain.
- **Do not use the body as a fulcrum. (Fig. F)**
- **Do not swing the lifted load.**
- **Do not wind the slack Load Chain with a load in one action to avoid exposing the Load Chain to shock.**
Stop lifting when the Load Chain is stretched tight. Then lift slowly.
- **Do not carry out reverse operation while lifting/lowering a load.**
When reversing the motion, stop the electric chain hoist and then reverse the motion.
- **Do not carry out excessively frequent inching.**
- **Do not carry out plugging.**
When reversing the motion, stop the electric chain hoist and then reverse the motion.
- **When lifting off a load from a pallet, lift the load to avoid exposing to shock, such as the load falling. (Fig. G)**
- **Do not cause the load to come into contact with the Load Chain.**
- **Do not rotate a lifted load. Use the device for rotation.**
- **Do not carry out the welding or cutting work on a lifted load.**
- **Do not repair or disassemble a lifted load.**
When repairing or disassembling an electric chain hoist, ensure that the product is placed down on the floor and that only maintenance engineers maintain the electric chain hoist.
- **Do not enter beneath a lifted load.**
- **Do not hit the Chain Container with a load or slinging devices.**
Otherwise the Load Chain in the Chain Container falls out of the bucket to cause injury.

Failure to comply with these instructions may result in death or serious injury.

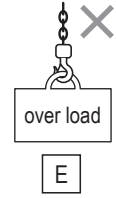

E

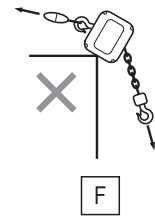

F



G



Mandatory

- **When the limit switch (over winding prevention device) is operated, stop the lifting work immediately and lower the load.**
- **Move the electric chain hoist right above the load and then lift the load. (Do not lift the load in an inclined direction.) (Fig. H)**
- **Do not leave from the operating position while a load is lifted. Watch the lifted load.**

Failure to comply with these instructions may result in death or serious injury.

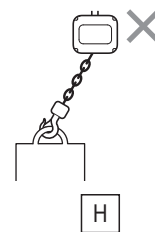

H

⚠ CAUTION

Prohibited

- Do not use the Friction Clutch to measure the weight of a load.

The use of the Friction Clutch other than intended purpose may result in injury or property damage.



Mandatory

- When carrying a lifted load using a lifting magnet or a vacuum chuck, lower the height of the lifted load as low as possible.
- When lifting a load with two electric chain hoists, use the electric chain hoist with the rated lifting capacity of a single hoist exceeding the load.
- When lifting a load with two electric chain hoists, use the electric chain hoists of the same model and capacity and operate the respective electric chain hoist to keep the load lifted or lowered horizontal.

Failure to comply with this instruction causes bodily injury or loss of property.

■ Traverse / Travel**⚠ DANGER**

Prohibited

- Do not operate the electric chain hoist underneath the load or transport a load over people. (Fig. I)
- Do not operate the electric chain hoist when any person is in the area where the lifted load moves.
- Do not allow people to enter into the area where a lifted load moves.
- Do not ride on a lifted load and do not use the electric chain hoist to support, lift, or transport people. (Fig. J)
- Do not strike the stopper or the structure by the body or the trolley.
- Do not operate or move the electric chain hoist while going backward with a load kept lifted.
Operate the electric chain hoist while looking forward from the back of a load and going ahead.

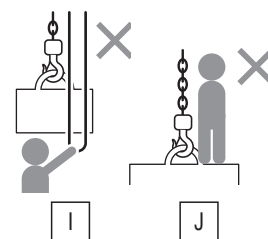

Failure to comply with these instructions may result in death or serious injury.

⚠ CAUTION

Prohibited

- Do not impede the lifted load with other structure or wiring.

Failure to comply with this instruction causes bodily injury or loss of property.



Mandatory

- If the Load Chain and the hand chain of the geared trolley are entangled, stop the operation immediately and reset the entangled chains.

Failure to comply with this instruction causes bodily injury or loss of property.

■ In Abnormality or Failure**⚠ DANGER**

Mandatory

- If the electric chain hoist is damaged or abnormal noise or vibration occurs, stop the operation immediately.
- If the electric chain hoist moves in the direction opposite to the indication on the Push Button Switch, stop the operation immediately.
- When the twist, entanglement, crack, deformation, attachment of foreign matters or abnormal engagement of the Load Chain and the Gear is observed, stop the operation immediately.
- When any abnormality is observed during the operation, indicate "FAILURE" and contact with the maintenance engineers.
- When the power is interrupted, secure safety and contact with the maintenance engineers.

Failure to comply with these instructions may result in death or serious injury.

(to be continued)

How to use (continued)

Speed Change of Dual Speed VFD Model

You can change the high/low speed of the dual speed VFD model by changing the VFD parameter.

⚠ DANGER



Prohibited

- **Only maintenance engineers or the personnel with expertise are allowed to set or change parameters.**
Wrong parameter settings may result in danger such as defective operation and drop of lifted load. Contact Please contact KITO for consultation.



Mandatory

- **When changing the parameter, set it correctly referring to the VFD Manual.**
- **Parameter change requires energizing. Do not touch the energized part.**

Failure to comply with these instructions may result in death or serious injury.

How to Sling the Load Properly

Do not carry out dangerous hooking as shown below.

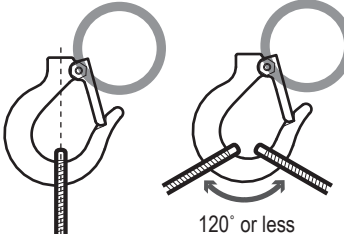

120° or less

Sling the load at the extended line of the hook shaft.



Improper hooking position of the lifted load or the sling



Angle exceeding 120°
Angle too wide



Unable closing of the Hook Latch



Hooking of the load at the tip of the Hook

How to Suppress the Swinging of a Load

⚠ DANGER



Prohibited

- **Do not move the electric chain hoist with a load hung at one side of the Crane Saddle.**
Otherwise the load swings and hits a person or object or drops to result in death or serious injury.

Swinging of a load makes it difficult and dangerous to move the trolley. The basics of operation are not to make a load swing. To do that keep the following instructions.

- Do not lift a load in an inclined direction.
- Start slowly when traveling the load.
- Do not lift suddenly.

Even if you keep the above instructions, the lifted load may swing at the start and the stop of the electric chain hoist.

Following operation can reduce the swing of the lifted load.

Operation

- 1) Press the Travel Button. (Fig. a)
- 2) When the trolley starts to move, the lifted load delays a bit. (Fig. b)
- 3) Release the button a bit before the time when the lifted load swings to the center position.
- 4) When the lifted load comes to the position just beneath the electric chain hoist, press the button again and continue to travel the load. (Fig. c)

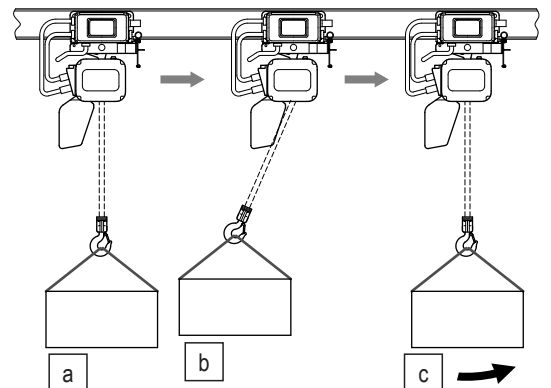

■ Precautions After Work

CAUTION



Prohibited

- Do not store the electric chain hoist at a state of over lifting or over lowering.

Failure to comply with these instructions causes bodily injury or loss of property.



Mandatory

- Store the electric chain hoist with power off.
- Indicate "FAILURE" on the electric chain hoist that needs repair not to be used.
- Wipe off dust and waterdrop, apply oil at the neck of the Hook and the Load Chain and store the hoist.
- Remove the stain, attached foreign matter and waterdrop from the parts such as the Limit Switch and the Chain Container that is scratched by the Load Chain or stored it.
- When the electric chain hoist is installed outdoor, cover it with rain cover or roof after application of rust proof process.

Failure to comply with these instructions causes bodily injury or loss of property.

NOTE

- Clean the push buttons always not to allow the dust and sands attach.
- When storing the electric chain hoist for a long period, it is effective to prevent rusting to operate it at a certain period without load.
- When putting the electric chain hoist on a floor, remove the Chain Container. Otherwise the Chain Container may deform or be damaged.
- When not using the electric chain hoist, wind up the Bottom Hook to the height not to hinder persons passing by or other work.
- Decide the place to store the electric chain hoist in advance. It is recommended to hang the push button set on the pillar.

Daily Inspection

Electric Chain Hoist

⚠ DANGER





- **Carry out daily inspection before use.**
(When any abnormality was found during inspection, turn off the power, indicate "FAILURE" and ask the maintenance engineer for repair.)

Neglecting to carry out daily inspection may result in death or serious injury.

Mandatory

- Refer to the technical material attached in Appendix (P124) for the structure of the product and the name of each part.

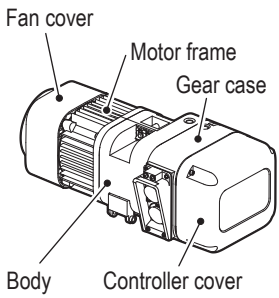
Appearance

Item	Check method	Criteria	When failed
Indication of nameplates and labels	<ul style="list-style-type: none"> • Check visually. 	<ul style="list-style-type: none"> • No peel off. Indication can be seen clearly. 	<p>Carry out cleaning, repair or replace with new nameplate or label.</p> <p>When replacing with a new nameplate or label is required, please inform KITO of the description in "Record of the Product No." (P15) such as Lot No. and Serial No.</p>
Deformation and damage of body and each part	<ul style="list-style-type: none"> • Check visually. 	<ul style="list-style-type: none"> • No apparent deformation, damage, flaw and crack 	<p>Replace the parts with deformation, damage, flaw or crack.</p>
Loosened or fallen off bolts, nuts and split pins	<ul style="list-style-type: none"> • Check visually. 	<ul style="list-style-type: none"> • Bolts, nuts and split pins are fastened securely. <div style="border: 1px solid black; padding: 5px; margin-top: 10px;"> <p style="text-align: center;">⚠ DANGER</p> <div style="display: flex; align-items: center;">  <div style="margin-left: 10px;"> <ul style="list-style-type: none"> • Even fallen off of a bolt causes for the body to drop. Be sure to check. <p>Fallen off of a bolt may result in death or serious injury.</p> </div> </div> <p style="font-size: x-small;">Mandatory</p> </div>	<p>Fasten bolts, nuts and split pins securely.</p>

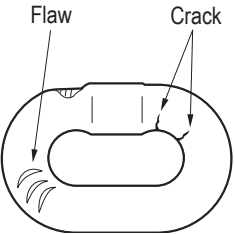
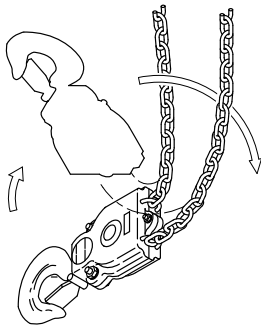

■ Load Chain

Item	Check method	Criteria	When failed
Elongation of Pitch	<ul style="list-style-type: none"> Check visually 	<ul style="list-style-type: none"> No apparent elongation 	Refer to Load Chain (P69) of Chapter 2, Monthly Inspection.
Abrasion of Wire Diameter	<ul style="list-style-type: none"> Check visually 	<ul style="list-style-type: none"> No apparent abrasion 	Refer to Load Chain (P69) of Chapter 2, Monthly Inspection.
Deformation, Flaw, Entanglement	<ul style="list-style-type: none"> Check visually  <ul style="list-style-type: none"> Check visually for no foreign matter such as attached sputter. 	<ul style="list-style-type: none"> No deep notch No deformation such as twist No attached sputter No entanglement No crack 	Replace the Load Chain.
Rust, Corrosion	<ul style="list-style-type: none"> Check visually 	<ul style="list-style-type: none"> No apparent rust and corrosion 	Replace the Load Chain.
Twist	<ul style="list-style-type: none"> Check visually 	<ul style="list-style-type: none"> No capsized link at Bottom Hook of double type Load Chain 	Untwist the Load Chain.
Lubrication	<ul style="list-style-type: none"> Check visually 	<ul style="list-style-type: none"> To be oiled adequately 	Apply oil.
Mark	<ul style="list-style-type: none"> Check visually 	<ul style="list-style-type: none"> To have no error in mark and marked pitch. (Refer to "Checking the Marks" (P15).) 	Replace the Load Chain.

(to be continued)

Daily Inspection (continued)

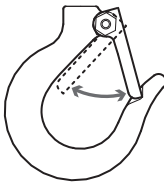
■ Top Hook/Bottom Hook

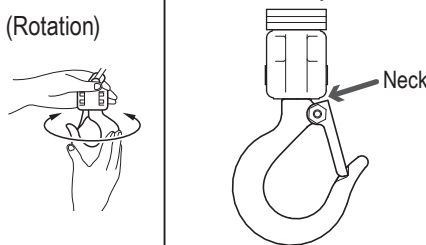
Item	Check method	Criteria	When failed
Opening of the Hook	<ul style="list-style-type: none"> Check visually 	<ul style="list-style-type: none"> No apparent opening of the Hook 	Carry out the inspection item of Top and Bottom Hook (P70) of Monthly Inspection.
Abrasion	<ul style="list-style-type: none"> Check visually 	<ul style="list-style-type: none"> No apparent abrasion 	Carry out the inspection item of Top and Bottom Hook (P70) of Monthly Inspection.
Deformation, Flaw, Corrosion	<ul style="list-style-type: none"> Check visually 	<ul style="list-style-type: none"> No apparent deformation, flaw and corrosion 	Carry out the inspection item of Top and Bottom Hook (P70) of Monthly Inspection.
Hook Latch 	<ul style="list-style-type: none"> Check visually and check the movement of the Hook Latch. 	<ul style="list-style-type: none"> The Hook Latch is mounted securely inside the Hook opening. No deformation. The Hook Latch moves smoothly. <div style="border: 1px solid black; padding: 5px; margin-top: 10px;"> <p style="text-align: center;">⚠ DANGER</p> <div style="display: flex; align-items: center;">  <div style="margin-left: 10px;"> <ul style="list-style-type: none"> Do not use the Hook without the Hook Latch. <p>Use of the Hook without the Hook Latch may result in death or serious injury.</p> </div> </div> </div>	Replace the Hook Latch.
Hook movement (Rotation) 	<ul style="list-style-type: none"> Check visually and rotate the Hook by hand. 	<ul style="list-style-type: none"> No apparent gap between the Bottom Yoke and the shank (at the neck). The Bottom Yoke rotates in both directions equally. The Bottom Yoke rotates smoothly. 	Replace the Hook.

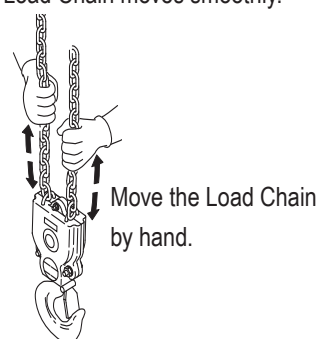
Item	Check method	Criteria	When failed
Movement of the Idle Sheave	<ul style="list-style-type: none"> Check the Idle Sheave by moving 	<div style="border: 1px solid black; padding: 5px; margin-bottom: 10px;"> <p style="text-align: center;">⚠ CAUTION</p> <div style="display: flex; align-items: center;"> <p> <ul style="list-style-type: none"> When checking, wear gloves and be careful for your finger not to be caught. </p> </div> <p>Mandatory Otherwise it may result in injury.</p> </div> <ul style="list-style-type: none"> The Idle Sheave rotates smoothly. * The Idle Sheave does not rotate smoothly when bearing is damaged or sheave shaft is deformed. The Load Chain moves smoothly. <div style="text-align: center;">  </div>	Replace the bearing of the Idle Sheave.
Bottom Yoke	<ul style="list-style-type: none"> Check visually. 	<ul style="list-style-type: none"> No loosened bolt or nut 	Attach the Bottom Hook to the Load Chain securely.

■ Peripheral parts of the body

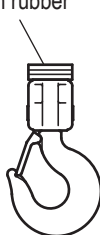
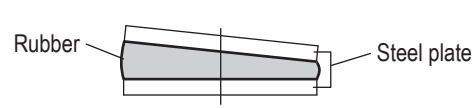
Item	Check method	Criteria	When failed
Chain Spring (Load side)	<ul style="list-style-type: none"> Check visually 	<ul style="list-style-type: none"> No apparent shrinkage or compression 	Carry out the inspection item of Chain Spring (P77) of Annual Inspection.
Cushion Rubber (Load side)	<ul style="list-style-type: none"> Check visually 	<ul style="list-style-type: none"> No apparent shrinkage or compression No peel off, crack or deformation of rubber 	Replace the Cushion Rubber.

(to be continued)

Daily Inspection (continued)**■ Push Button Switch**

Item	Check method	Criteria	When failed
Switch body	<ul style="list-style-type: none"> Check visually 	<ul style="list-style-type: none"> No deformation, damage and no loosened screw Label indication of the push button switch can be seen clearly. 	Clean and repair the label or replace with a new label. Affix the label securely.

■ Function and Performance

- Check the following item with no load.

Item	Check method	Criteria	When failed
Operational Check	<ul style="list-style-type: none"> Press the push button and check each operation. 	<ul style="list-style-type: none"> The Load Chain can be wound smoothly. The Electric chain hoist moves in the same direction as that of the push button operation. When the operation is stopped, the motor stops immediately. When the Emergency Stop Button is pressed, all hoist motions stop. When operating other push button while the Emergency Stop Button is pressed, the hoist does not start operation. When canceling the Emergency Stop Button, the hoist operates normally. 	Take measures by referring to Chapter 3 "Guidance on Troubleshooting". (P96)
Brake	<ul style="list-style-type: none"> Press the push button and check the operation of the Brake. 	<ul style="list-style-type: none"> When stopping the operation, the Brake is applied immediately and the Bottom Hook shall stop immediately. (Guideline: The travel of the Load Chain is within 2 to 3 links.) 	Carry out the inspection in accordance with the items in Chapter 2 "Annual Inspection" Electromagnetic Brake (P79).
Friction Clutch with Mechanical Brake	<ul style="list-style-type: none"> Press the push button and check the operation of the Friction Clutch. 	<ul style="list-style-type: none"> When lifting, the sound of pawl clicks regularly. (For the friction clutch of standard specification makes no pawl sound.) 	Disassemble the hoist and check Friction clutch.
Limit Switch	<ul style="list-style-type: none"> Press the push button and check the operation of the Limit Switch. 	<ul style="list-style-type: none"> When the hoist is operated to the upper or lower limit, the motor automatically stops. 	Replace the Limit Switch. Disassemble the actuator of the Limit Switch to clean.
Abnormal Sound	<ul style="list-style-type: none"> Press the push button and check the operation. <div style="border: 1px solid black; padding: 5px; margin-top: 10px;"> <p style="text-align: center;">NOTE</p> <p>Sound is also an important check point. Always be careful for the noise of the electric chain hoist.</p> </div>	<ul style="list-style-type: none"> No abnormal sounds and vibrations 	Replace the abnormal part. Apply oil on the Load Chain.
		<ul style="list-style-type: none"> No popping sound from the Load Chain. 	Check the Load Chain. (Refer to P29.)

Motorized Trolley

Appearance

Item	Check method	Criteria	When failed
Indication of Nameplates and Labels	<ul style="list-style-type: none"> Check visually 	<ul style="list-style-type: none"> No peel off. Indication can be seen clearly. 	Clean and repair the label or replace with a new label.
Deformation and damage of each part	<ul style="list-style-type: none"> Check visually 	<ul style="list-style-type: none"> No apparent deformation, damage and corrosion 	Replace the deformed or damaged part.
Loosened or fallen off bolts, nuts and split pins	<ul style="list-style-type: none"> Check visually 	<ul style="list-style-type: none"> Bolts, nuts and split pins are fastened securely. <div data-bbox="662 1476 1135 1742" style="border: 1px solid black; padding: 5px;"> <p style="text-align: center;">⚠ DANGER</p> <p>!</p> <ul style="list-style-type: none"> Even a drop off of a split pin may cause of drop of the body. Be sure to check it. <p>Mandatory</p> <p>Drop off of split pin may result in death or serious injury.</p> </div>	Fasten bolts, nuts and split pins securely.

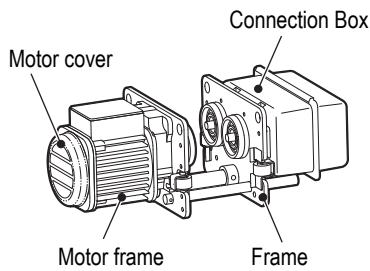

(to be continued)

Daily Inspection (continued)**■ Function and Performance**

- Check the following item with no load.

Item	Check method	Criteria	When failed
Operational Check	<ul style="list-style-type: none"> • Press the push button to check the operation. 	<ul style="list-style-type: none"> • To travel smoothly. No serpentine motion and vibration. • The electric chain hoist moves in the same direction as that of the push button operation. • When the operation is stopped, the motor stops immediately. • When the Emergency Stop Button is pressed, all hoist motions stop. • When operating other push button while the Emergency Stop Button is pressed, the hoist does not start operation. • When canceling the Emergency Stop Button, the hoist operates normally. 	Take measures by referring to Chapter 3 "Guidance on Troubleshooting". (P96).
Brake	<ul style="list-style-type: none"> • Press the push button to check the operation of the Brake. 	<ul style="list-style-type: none"> • When the operation is stopped, the Brake is applied and the motor stops immediately. 	Carry out the inspection in accordance with the items in Chapter 2 "Annual Inspection" Brake (P84).

■ Manual Trolley**■ Appearance**

Item	Check method	Criteria	When failed
Indication of Nameplates and Labels	<ul style="list-style-type: none"> • Check visually 	<ul style="list-style-type: none"> • No peel off. Indication can be seen clearly. 	Clean and repair the label or replace with a new label.
Deformation and damage of each part	<ul style="list-style-type: none"> • Check visually 	<ul style="list-style-type: none"> • No apparent deformation and corrosion • No apparent deformation on the Frame 	Replace the deformed or damaged part.
Loosened or fallen off bolts, nuts and split pins	<ul style="list-style-type: none"> • Check visually 	<ul style="list-style-type: none"> • Bolts, nuts and split pins are fastened securely. <div style="border: 1px solid black; padding: 5px; margin-top: 10px;"> <p style="text-align: center;">⚠ DANGER</p> <p>!</p> <ul style="list-style-type: none"> • Even a drop off of a split pin may cause of drop of the body. Be sure to check it. <p>Mandatory</p> <p>Drop off of split pin may result in death or serious injury.</p> </div>	Fasten bolts, nuts and split pins securely.

■ Function and Performance

- Check the following item with no load.

Item	Check method	Criteria	When failed
Operational Check	<ul style="list-style-type: none">• Check the traveling motion of the trolley by moving it manually.	<ul style="list-style-type: none">• To travel smoothly. No serpentine motion and vibration.	Carry out Chapter 2 "Annual Inspection" (P88).

Work Flow of Assembling and Installation

The contents of the work to assemble and install the product by the maintenance engineers and installer are described from this page and after. To eliminate the redo work and for effective assembling and installation, please check the following work flow first and then start assembling and installation work.

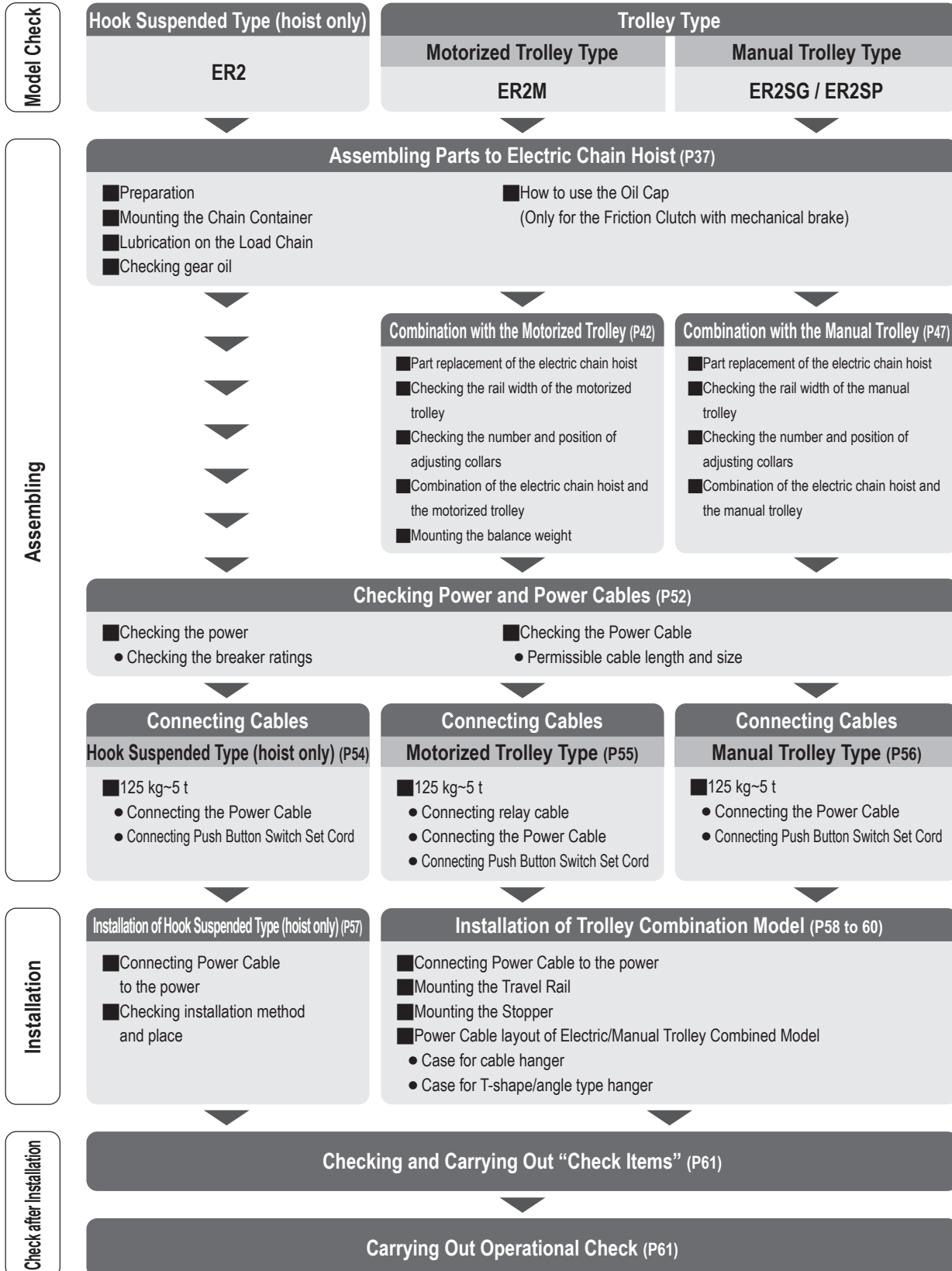

Assembling

DANGER



Prohibited

- Only maintenance engineers or the personnel with expertise are allowed to assemble and disassemble the electric chain hoist.

Assembling or disassembling of the electric chain hoist may result in death or serious injury.

■ Assembling Parts to Electric Chain Hoist

DANGER



Mandatory

- **Check the Load Chain size and lift of the electric chain hoist and be sure to use an appropriate Chain Container.**

Failure to use an appropriate Chain Container may result in one of the following scenarios, which can lead to a major accident involving death or serious injury.

- The Load Chain falls out of the Chain Container
- The Load Chain becomes entangled in the Chain Container
- The electric chain hoist malfunctions
- **Be sure to correctly mount the Chain Container.**

Failure to do so may result in the Chain Container or Load Chain falling down, which can lead to a major accident involving death or serious injury.

- **If you do not wish to use a Chain Container, secure the end of the Load Chain on the no-load side to the main body of the electric chain hoist.**

The Load Chain on the no-load side may become entangled with the Load Chain on the load side, causing the electric chain hoist to malfunction. This may result in a major accident involving death or serious injury.

■ Preparation for Assembling

- Be sure to prepare all necessary tools and always wear the appropriate protective equipment.
- Ensure that all parts to be installed are compatible with the electric chain hoist.
- Suspending the electric chain hoist main body may make it easier to install parts.

■ Mounting the Chain Container

The three types of the Chain Container are provided: bucket made of plastic, canvas and steel

If the end suspender is installed, remove them before installing the chain container.

This manual describes the method to combine the plastic or canvas Chain Container with the body of the electric chain hoist. Refer to the separate "Mounting Manual of the Steel Chain Container" for the steel Chain Container.

CAUTION



Mandatory

- **When storing the Load Chain into the Chain Container, put the chain end with no-load side first and then store the rest of the Load Chain.**

Failure to comply with these instructions causes bodily injury or loss of property.

(to be continued)

Assembling (continued)

● Checking the Chain Container

A sticker that contains the following information is attached to the Chain Container. (See the figure to the right.)

Confirm that the information on this sticker matches the specifications of the electric chain hoist on which the Chain Container is to be installed.

- The body size of the compatible electric chain hoist (Example: Body size "C")
- The size of the Load Chain that can be stored (Example: $\phi 6$ mm)
- The maximum lift (Example: 6 m)



● Plastic Container

1) Mount the Container Spring to the Chain Guide A.

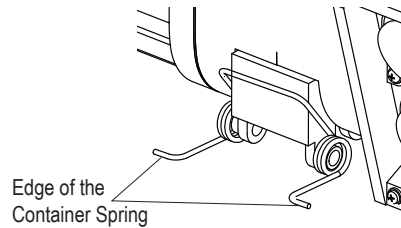

2) Pass a Socket Bolt through all holes of the Chain Container, the Chain Guide A and the Chain Container, in this order to mount the Chain Container.

- Be careful to the direction of the Container Spring.
- As the portion A shown in the right assembly figure, make sure that the edge of the Container Spring is set out of the container when assembling.

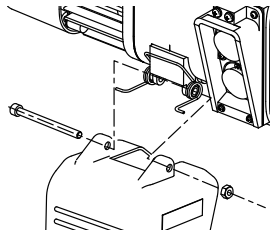

3) Screw the U nut into the Socket Bolt and tighten it securely.

- The Socket Bolt must protrude from the end face of the nut by three threads or more.

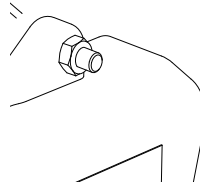

● Canvas Container

1) Pass two Socket Bolts through all holes of the Chain Guide A, the Canvas Container and the Chain Guide A in this order to mount the Chain Container.

2) Screw the U nut securely.

- The Socket Bolt must protrude from the end face of the nut by three threads or more.

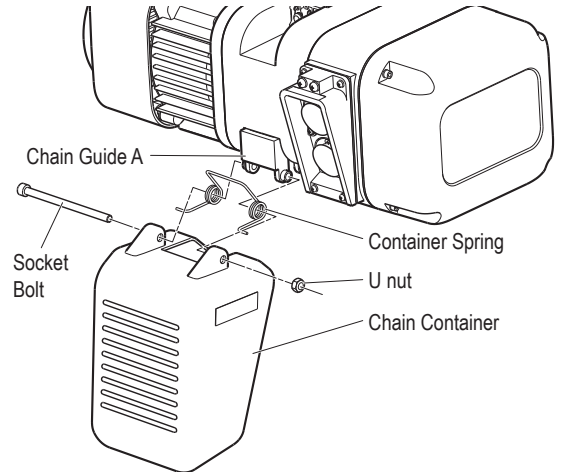

Names of each part

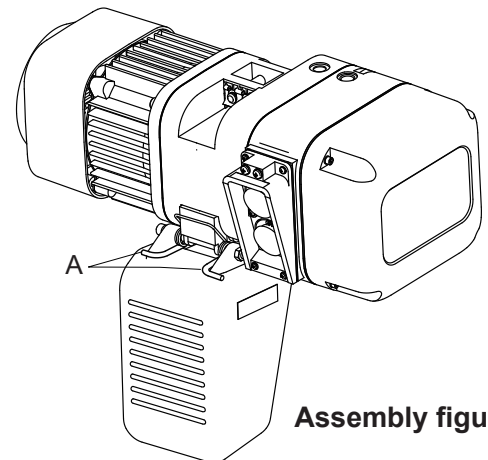

Assembly figure

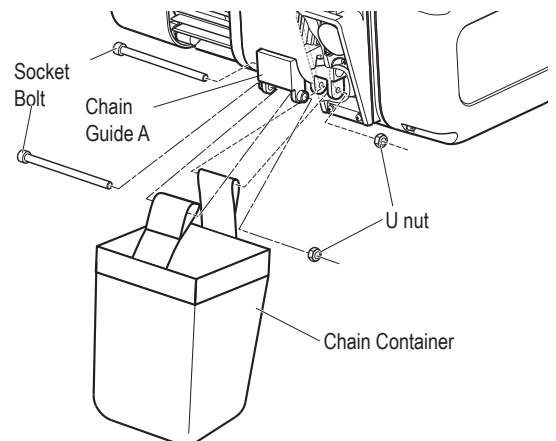

■ Securing the End of the Load Chain

When using the hoist without a Chain Container installed, it is necessary to secure the end of the Load Chain.

Refer to page 123 to order the parts required to secure the Load Chain.

Use the following procedure to secure the Load Chain to the Chain End Suspender or Chain Guide A.

1) Confirm the securing method

- For electric chain hoists with a rated load of 125 kg to 2.5 t or less, use a Chain End Suspender to secure the Load Chain.
- For electric chain hoists with a rated load of 2.8 t or more, directly secure the Load Chain to Chain Guide A on the main body.

2) Install the Stopper

- Before securing the Load Chain, install a Stopper on the no-load side of the Load Chain according to the following table.
- If a Stopper is already installed, reinstall it at the appropriate position shown in the following table.

Rated load	Stopper installation position (The number of links from the end of the Load Chain on the no-load side.)
125kg~250kg	21
500kg~5t or less	15

3) Secure the Load Chain

- Secure it using a Chain End Suspender
- Confirm that the Load Chain on the no-load side has no twists, and attach the end link to the Chain End Suspender using a socket bolt and lever nut. (A washer is not needed in the case of a 2.5 t hoist.)

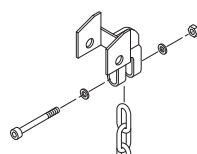

(125kg ~ 2t)

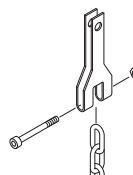

(2.5t)

- Connect the Chain End Suspender and Chain Guide A using a socket bolt and lever nut.

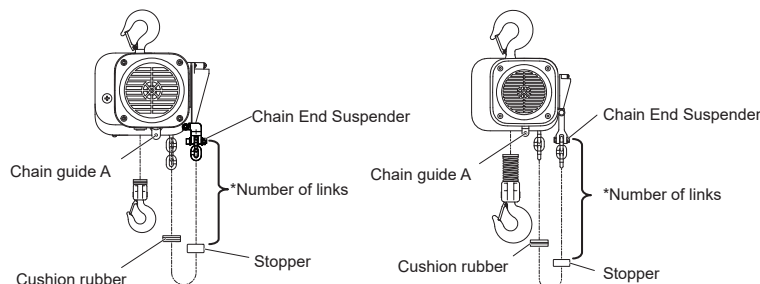

(125kg ~ 2t)

(2.5t)

- Secure it to the Chain Guide
- Confirm that the Load Chain has no twists, and secure the end of the Load Chain to Chain Guide A using a socket bolt and lever nut.

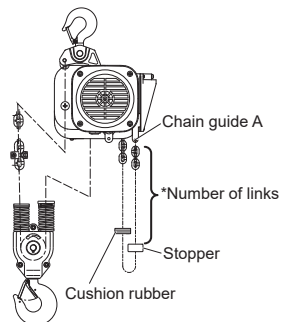

Assembling (continued)

■ Oiling the Load Chain

⚠ DANGER



Mandatory

- Be sure to apply lubricant on the Load Chain. Do not carry out oiling work in the place near the fire or arc.

Otherwise it will result in fire.

Remove dust and waterdrops attached on the Load Chain and then apply lubricant. Application of lubricant influences on the life of the Load Chain considerably. Apply the lubricant sufficiently.

Use the following genuine lubricant.

- Epinoc Grease AP (N)0 (ENEOS Corp.)
- Consistency No.0 (Industrial general lithium grease)

Release all loads from the Load Chain. Apply the lubricant to the linking portion of the Load Chain that engages the Load Sheave and the Idle Sheave (hatched area).

After application of the lubricant lift/lower the electric chain hoist without load to spread the lubricant on the Load Chain.

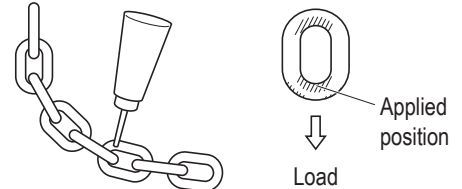

■ Gear Oil

Inside of the Gear Case is filled with gear oil at the shipping. The level of the oil filled with specified amount comes to the height of the inspection hole. Check the oil level visually.

⚠ DANGER



Mandatory

- Set the body to a level and then check the level of gear oil.

When removing the oil plug without leveling the electric chain hoist, the gear oil flows out. It will result in death or serious injury due to fall by slippery floor.



Mandatory

- Use genuine gear oil.

Use of the gear oil other than the genuine oil (including mixed use) will result in death or serious injury due to the drop of the lifted load.

● Cheking the Gear Oil Amount

- 1) ER2 Body size B/C/D: Remove the Oil Plug on the Main Body at the opposite side of the Chain Container.

ER2 Body size E/F: Remove the Oil Plug on the Main Body at the same side of the Chain Container.

- 2) If the oil level can be seen close to the Oil Check Hole, the oil amount is normal.

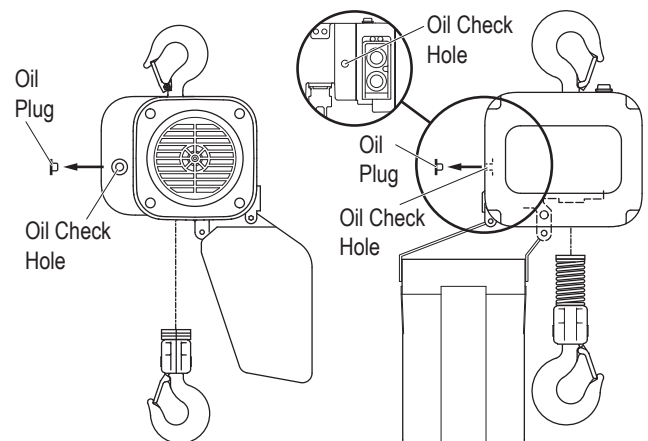

Body size ER2-B/C/D

Body size ER2-E/F

■ How to Use the Oil Cap (only for the Friction Clutch with mechanical brake)

An Oil Cap is packaged along with the electric chain hoist equipped with built-in Friction Clutch with mechanical brake (option). When installing the hoist, remove the oil plug and attach the Oil Cap instead. When combining the motorized trolley, mount the oil cap to the hoist at a position where the Oil Cap and the frame of the Trolley do not interfere. (Any one of the following two positions)

⚠ DANGER



Mandatory

- The gear oil for the electric chain hoist with Friction Clutch with mechanical brake is different from that for the hoist with standard Friction Clutch. Be sure to use the genuine gear oil for the hoist with friction clutch with mechanical brake.

Use of the gear oil other than the specified oil (including mixed use) will result in death or serious injury due to the drop of the lifted load.

● When using the electric chain hoist

To secure the draft between inside and outside of the Gear Case, pull out the Air Vent to the position where the step of the Air Vent can be seen.

● When removing the electric chain hoist

To prevent the oil flow out from inclined electric chain hoist, make sure that the Air Vent is inserted securely.

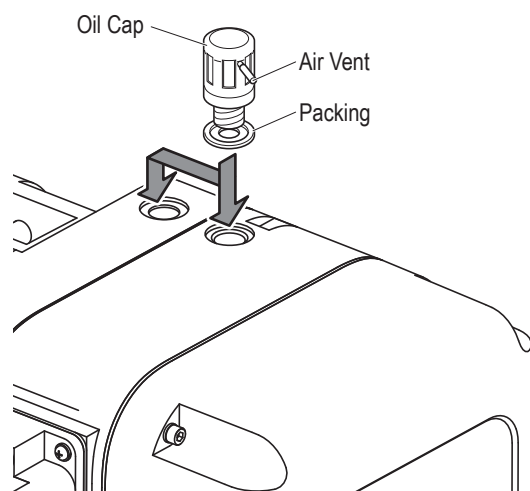

■ Combination with the Trolley

* When using the Hook suspended model (Single Unit) "Checking Power and Power Cable", you can skip this section. Please proceed with Page 52.

⚠ DANGER



Mandatory

- Adjust the rail width during assembling and install.
- Be careful for the Power Cable and Push Button Switch Set Cord are not pulled off or entangled within the area of traveling area.

Failure to comply with these instructions may result in death or serious injury.

(to be continued)

Assembling (continued)

Combining with the Motorized Trolley

CAUTION



Prohibited

- When using ER2 series electric chain hoist combined with our old type product, specification needs to be changed. Contact your nearest dealer or KITO.

Parts replacement of the electric chain hoist

The Suspender is attached to the electric chain hoist at shipping.

Refer to the following figure to remove the Top Hook and replace the Suspender with the Suspender T.

Replacing the Top Hook of Body size ER2-B/C/D/E

- Remove the Shaft Retainer Clip using plier.
- Remove the Socket Bolt from the Shaft Retainer, and remove the Shaft Retainer.
- Remove two Connection Shafts.
- Remove the Top Hook and replace it with the Suspender T.
- Insert two Connection Shafts into the hole of the Body.
- Mount the Shaft Retainer with Socket Bolt.

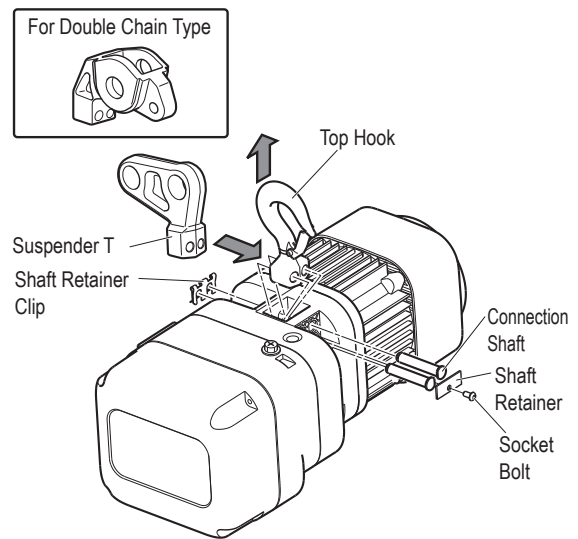

Replacing the Top Hook of Body size ER2-F

- Remove four Socket Bolts and remove the Controller Cover.
- Remove pan head screws of the Connection Shaft and the Fixing Shaft (two screws each), and remove the Shaft Retainer.
- Pinch the respective upper ends of the Connection Shaft and the Fixing Shaft and pull out them.
- Remove the Top Hook and replace it with the Suspender T.
- Insert the Connection Shaft and Fixing Shaft into the mounting hole.
- Fix the Shaft Retainer of the Connection Shaft and the Fixing Shaft with pan head screws (two screws each).
- Mount the Controller Cover with four pan head screws.

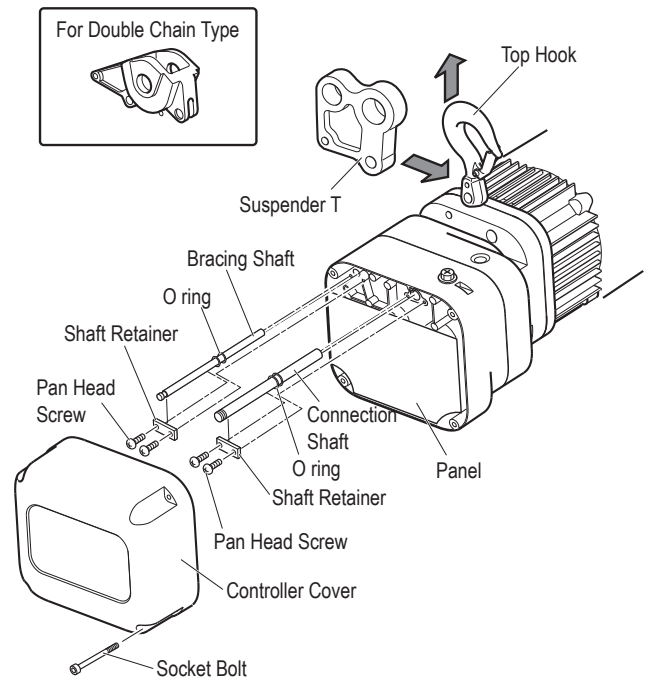

■ Checking the Number of the Assembled Adjusting Spacers and Their Positions

When installing a trolley to the beam, the length of the Suspension Shaft (width between frames) must be adjusted in accordance with the rail width.

Wrong number of wrong position of Spacers may result in the drop of the electric chain hoist.

Insert the correct number of Spacers with correct ratings and for rail width at the correct position, referring to the following table.

• Adjusting spacer arrangement for LOW Head Suspension (Beam flange width 58-170mm)

Beam flange width		Number of Adjusting Spacers																													
		(in)	2 ⁵ / ₁₆	2 ¹ / ₂	2 ⁷ / ₈	3	3 ¹ / ₄	3 ⁹ / ₁₆	3 ⁷ / ₈	3 ¹⁵ / ₁₆	4	4 ³ / ₁₆	4 ⁵ / ₁₆	4 ⁷ / ₁₆	4 ¹¹ / ₁₆	4 ¹⁵ / ₁₆	5	5 ³ / ₁₆	5 ⁵ / ₁₆	5 ³ / ₈	5 ⁵ / ₈	5 ¹¹ / ₁₆	6	6 ¹ / ₈	6 ⁵ / ₁₆	6 ⁷ / ₁₆	6 ¹¹ / ₁₆				
Capacity (t)	Parts Name	(mm)	58	64	73	75	82	90	98	100	102	106	110	113	119	120	125	127	131	135	137	143	149	150	153	155	160	163	170		
	1	Thin spacer	Inner	1+2	2+3	4+4	1+0	1+2	2+3	0	1+0	1+2	2+2	2+3	3+4	4+4	4+1	5+1	2+2	3+3	4+4	4+1	4+1	4+1	4+1	1+1	2+2	2+3	3+0	3+0	
Outer			5	3	0	7	5	3	8	7	5	4	3	1	0	3	2	4	2	0	3	6	4	3	5						
Thick spacer		Inner	0				1+1				1+2				2+2				2+3		3+3		3+4								
		Outer	5				3				0				2		1		0		3		2								
Fixing spacer		Inner	0																												
		Outer	2																												
Thick spacer L		Inner	0	1+1																											
		Outer	2	0																											
2		Thin spacer	Inner				1+2	2+3	3+4	0	1+0	1+1	1+2	2+2	3+3	4+4	1+0	1+1	1+2	2+2	3+3	4+0	4+1	1+1	1+2	2+2	3+3	4+1	1+1	2+2	3+3
			Outer				5	3	1	8	7	6	5	4	2	0	7	6	5	4	2	4	3	6	5	4	2				
	Thick spacer	Inner	0				1+1				1+2				2+2		2+3		2+2												
		Outer	5				3				2		1																		
	Fixing spacer	Inner	0																												
		Outer	2																												
	Thick spacer L	Inner	0	1+1																											
		Outer	2	0																											
	3	Thin spacer	Inner				1+2	2+3	3+4	0	1+0	1+1	1+2	2+2	3+3	4+4	1+0	1+1	1+2	2+2	3+3	4+0	4+1	1+1	1+2	2+2	3+3	4+1	1+1	2+2	3+3
			Outer				5	3	1	8	7	6	5	4	2	0	7	6	5	4	2	4	3	6	5	4	2				
Thick spacer		Inner	0				1+1				1+2				2+2		2+3		2+2												
		Outer	5				3				2		1																		
Fixing spacer		Inner	0																												
		Outer	2																												
Thick spacer L		Inner	0	1+1																											
		Outer	2	0																											
5		Thin spacer	Inner							0	1+0	1+1	1+2	2+2	3+3	0	1+0	1+1	2+2	3+3	4+0	4+1	1+1	2+2	3+3	4+0	4+1	1+1	2+2	3+0	
			Outer							8	7	6	5	4	2	8	7	6	4	2	4	2	4	3	6	4	3	5			
	Thick spacer	Inner	0				0+1				1+1				1+2		1+2														
		Outer	3				2				1		0																		
	Fixing spacer	Inner	0																												
		Outer	2																												
	Thick spacer L	Inner	0	1+1																											
		Outer	2	0																											

Remarks) 1) Description for inner spacers

For example, 0+1

0 : the number of spacers on the left side of the shaft

1 : the number of spacers on the right side of the shaft

2) Adjustment of trolley width

Adjust the dimensions by appropriately increasing or decreasing the number of inner or outer adjusting spacers shown in the above table.

(to be continued)

Assembling (continued)

• **Adjusting spacer arrangement for LOW Head Suspension (Beam flange width 175-305mm)**

Beam flange width		Number of Adjusting Spacers																																							
		(in)	6 ⁷ / ₈	7	7 ⁷ / ₁₆	7 ¹ / ₄	7 ⁷ / ₈	8	8 ⁷ / ₁₆	8 ¹¹ / ₁₆	9	9 ¹ / ₈	9 ⁷ / ₈	10	10 ¹ / ₈	10 ¹ / ₄	10 ³ / ₈	10 ¹ / ₂	11	11 ¹ / ₈	11 ¹ / ₄	11 ³ / ₈	11 ⁵ / ₈	11 ³ / ₄	11 ⁹ / ₁₆	11 ⁷ / ₈	12														
Capacity (t)	Parts Name	(mm)	175	178	180	184	181	185	200	203	215	220	229	232	250	254	257	260	264	267	279	283	286	289	295	298	300	302	305												
1	Thin spacer	Inner	4+4	4+1	1+1	1+2	4+4	5+0	2+3	3+4	1+1	1+2	4+0	1+1	1+2	2+2	2+3	3+3	1+1	1+2	2+2	2+3	3+0	4+0	4+1	4+2															
		Outer	0	3	6	5	0	3	3	1	6	5	4	6	5	4	3	2	6	5	4	3	5	4	3	4	3	2													
	Thick spacer	Inner	3+3	3+4	0		0+1	1+1	2+2	2+3	3+3			4+4			4+5																								
		Outer	3	2	9		8	7	5	4	3			1			0																								
	Fixing spacer	Inner	0	1+1																																					
		Outer	2	0																																					
	Thick spacer L	Inner	1+1																																						
		Outer	0																																						
	2	Thin spacer	Inner	4+4	1+4	1+1	1+2	4+4	1+0	2+3	3+3	4+1	1+1	4+4	4+1	5+1	4+3	2+3	3+3	4+1	1+2	2+2	2+3	3+3	3+4	4+4	3+4	4+4	4+1	5+1											
			Outer	0	3	6	5	0	7	3	2	3	6	0	3	2	1	3	2	3	5	4	3	2	1	0	3	2													
		Thick spacer	Inner	2+2	3+2	0		1+1		1+2	2+2	2+3			3+3			3+4	4+4			4+5																			
			Outer	1	0	9		7		6	5	4			3			2	1			0																			
Fixing spacer		Inner	1+1		1+1																																				
		Outer	0		0																																				
Thick spacer L		Inner	1+1																																						
		Outer	0																																						
3		Thin spacer	Inner	4+4	1+4	1+1	1+2	4+4	1+0	2+3	3+3	4+1	1+1	4+4	4+1	5+1	4+3	2+3	3+3	4+1	1+2	2+2	2+3	3+3	3+4	4+4	3+4	4+4	4+1	5+1											
			Outer	0	3	6	5	0	7	3	2	3	6	0	3	2	1	3	2	3	5	4	3	2	1	0	3	2													
		Thick spacer	Inner	2+2	3+2	0		1+1		1+2	2+2	2+3			3+3			3+4	4+4			4+5																			
			Outer	1	0	9		7		6	5	4			3			2	1			0																			
	Fixing spacer	Inner	1+1		1+1																																				
		Outer	0		0																																				
	Thick spacer L	Inner	1+1																																						
		Outer	0																																						
	5	Thin spacer	Inner	4+4	4+1	5+1	4+3	4+4	1+0	2+3	3+4	1+1	1+2	4+4	1+1	1+2	2+2	2+3	3+3	5+1	1+2	2+2	2+3	4+3	4+4	4+0	4+1	5+1													
			Outer	0	3	2	1	0	7	3	1	6	5	0	6	5	4	3	2	5	4	3	1	0	4	3	2														
		Thick spacer	Inner	1+1	1+2		2+2	3+3			4+4			5+5			5+6	6+6			6+7																				
			Outer	1	0	10	9	7			5			3			2	1			0																				
Thick spacer L		Inner	1+1																																						
		Outer	0																																						

Remarks) 3) Thin Spacer arrangement example

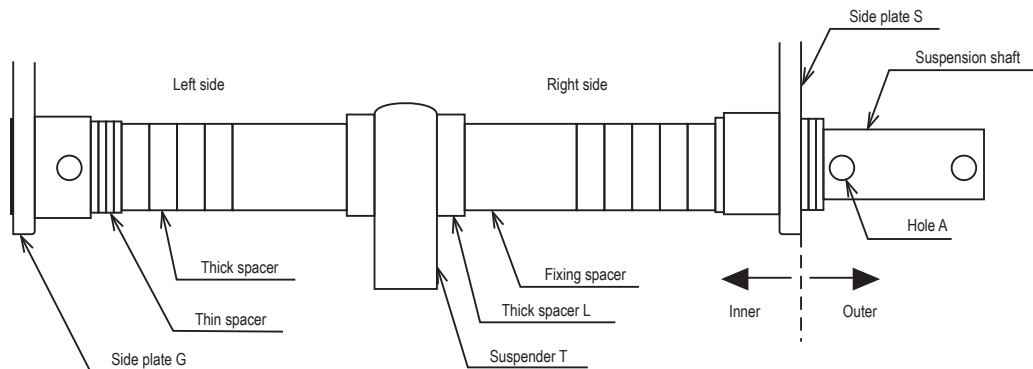

• **Adjusting spacer arrangement for Lug Suspension**

		Number of Adjusting Spacers																														
Beam flange width	(in)	2 ⁵ / ₁₆	2 ¹ / ₂	2 ⁷ / ₈	3	3 ¹ / ₄	3 ⁹ / ₁₆	3 ⁷ / ₈	3 ¹⁵ / ₁₆	4	4 ³ / ₁₆	4 ⁵ / ₁₆	4 ⁷ / ₁₆	4 ¹¹ / ₁₆	4 ¹⁵ / ₁₆	5	5 ³ / ₁₆	5 ⁵ / ₁₆	5 ³ / ₈	5 ⁵ / ₈	5 ¹¹ / ₁₆	6	6 ¹ / ₈	6 ⁵ / ₁₆	6 ⁷ / ₁₆	6 ¹¹ / ₁₆						
Capacity (lb)	Parts Name	(mm)	58	64	73	75	82	90	98	100	102	106	110	113	119	120	125	127	131	135	137	143	149	150	153	155	160	163	170			
5	Thin spacer														0	1+0	1+1	1+2	2+2	3+3	0	1+0	1+1	2+2		3+3	4+0	4+1	1+1	2+2	2+3	3+0
															8	7	6	5	4	2	8	7	6	4		2	4	3	6	4	3	5
	Thick spacer														0			1+1			1+2		2+2		2+3							
															5			3			2		1		0							

		Number of Adjusting Spacers																											
Beam flange width	(in)	6 ⁷ / ₈	7	7 ¹ / ₁₆	7 ¹ / ₄	7 ¹ / ₈	8	8 ¹ / ₁₆	8 ¹¹ / ₁₆	9	9 ¹ / ₈	9 ⁷ / ₈	10	10 ¹ / ₈	10 ¹ / ₄	10 ³ / ₈	10 ¹ / ₂	11	11 ¹ / ₈	11 ¹ / ₄	11 ³ / ₈	11 ⁵ / ₈	11 ³ / ₄	11 ¹³ / ₁₆	11 ⁷ / ₈	12			
Capacity (lb)	Parts Name	(mm)	175	178	180	184	181	185	200	203	215	220	229	232	250	254	257	260	264	267	279	283	286	289	295	298	300	302	305
5	Thin spacer		4+4	4+1	5+1	4+3	4+4	1+0	2+3	3+4	1+1	1+2	4+4	1+1	1+2	2+2	2+3	3+3	5+1	1+2	2+2	2+3	4+3	4+4	4+0	4+1	5+1		
			0	3	2	1	0	7	3	1	6	5	0	6	5	4	3	2	5	4	3	1	0	4	3	2			
	Thick spacer		2+2	2+3		3+3	4+4		5+5		6+6			6+7		7+7			7+8										
			1	0	10	9	7		5		3			2		1			0										

(to be continued)

Assembling (continued)

Combination of the Electric Chain Hoist and the Motorized Trolley

⚠ DANGER



Mandatory

- Use new split pins. After insertion, bend the pin securely at its both ends.

Use of old split pins may result in death or serious injury due to drop.

● 125 kg~5 t

1) Fix the Suspension Shaft to the Frame G with a Suspension Shaft Bolt, a slotted nut and a split pin.

- When fixing the Frame S and the Suspension Shaft, use the hole A. If the gap between the rail end and the wall of the housing is scarce to install the electric chain hoist to the travel rail, use the hole B. (Refer to "Mounting the Hoist to the Travel Rail" (P58).)

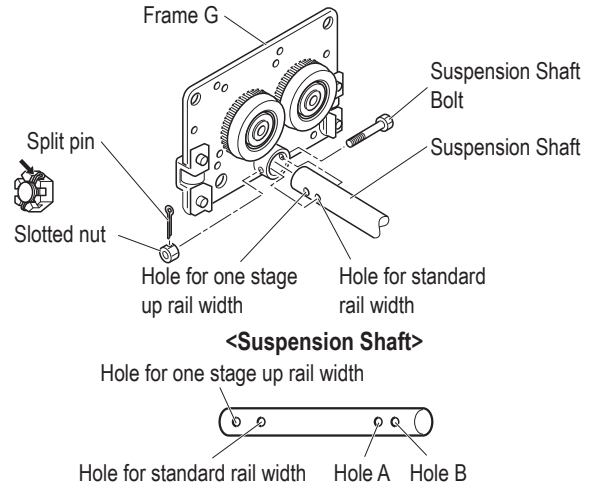

⚠ DANGER



Prohibited

- The hole B on the Suspension Shaft is the hole for mounting work (temporary assembly). Do not use the hole for the adjustment of rail width.

Failure to comply with this instruction may result in death or serious injury.

2) Fix the Fixing Shaft to the Frame G with a split pin.

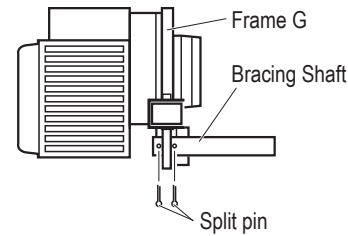

3) Set the Suspension Shaft with a Thin Spacer, Thick Spacer and a Thick Spacer L.

4) Set the Suspender T of ER2 Body with the Suspension Shaft and the Fixing Shaft.

5) Set the Suspension Shaft with another Thin Spacer, Thick Spacer and Thick Spacer L. Then insert the Suspension Shaft into the Frame S.

- Adjust the Spacers in accordance with the rail width. (Refer to "Checking the Number of the Assembled Adjusting Spacers and their positions" (P43) for the number of Spacers.)

6) Set the Suspension Shaft with a Thick Spacer. Insert the Shaft Stopper Pin into the Hole A and fix it with a split pin.

- Insert the Shaft Stopper Pin in the direction that the split pin comes to the left when viewed from the front side of the MR2 Connection Box.

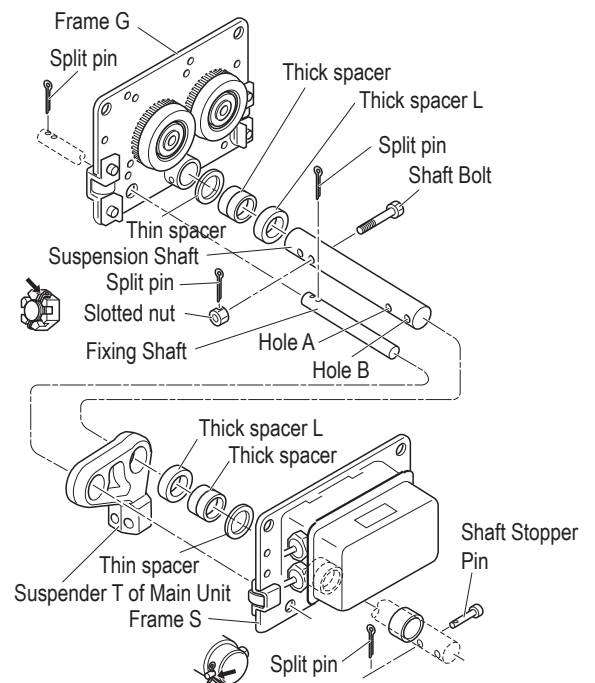

■ Combination with the Manual Trolley

■ Parts replacement of the Electric Chain Hoist

Remove the Top Hook and replace it with a Connection Yoke.

● Replacing the Top Hook of Body size ER2-B/C/D/E

- 1) Remove the Shaft Retainer Clip using plier.
- 2) Remove Socket Bolt from the Shaft Retainer, and remove the Shaft Retainer.
- 3) Remove two Connection Shafts.
- 4) Remove the Top Hook and replace it with the Connection Yoke.
- 5) Insert two Connection Shafts into the hole of the Body.
- 6) Mount the Shaft Retainer with Socket Bolt.

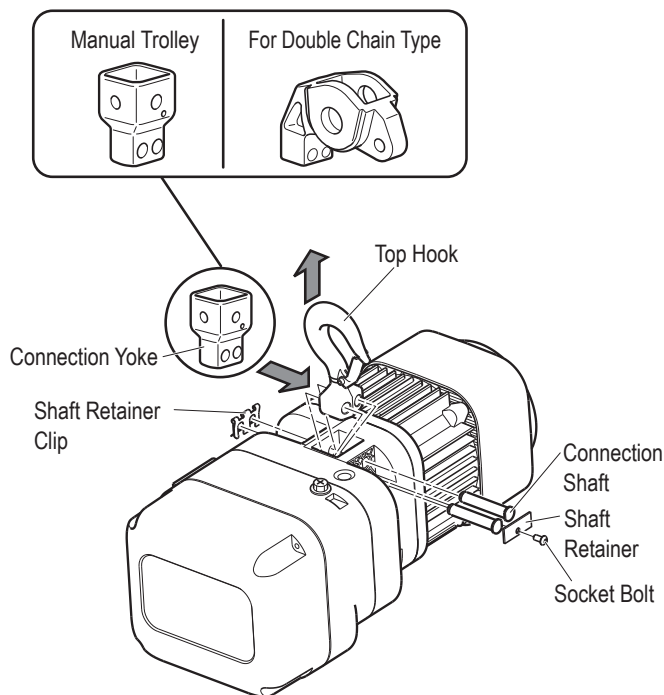

● Replacing the Top Hook of Body size ER2-F

- 1) Remove four Socket Bolts and remove the Controller Cover.
- 2) Remove pan head screws of the Connection Shaft and the Fixing Shaft (two screws each), and remove the Shaft Retainer.
- 3) Pinch the respective upper ends of the Connection Shaft and the Fixing Shaft and pull out them.
- 4) Remove the Top Hook and replace it with the Suspender T.
- 5) Insert the Connection Shaft and Fixing Shaft into the mounting hole.
- 6) Fix the Shaft Retainer of the Connection Shaft and the Fixing Shaft with pan head screws (two screws each).
- 7) Mount the Controller Cover with four pan head screws.

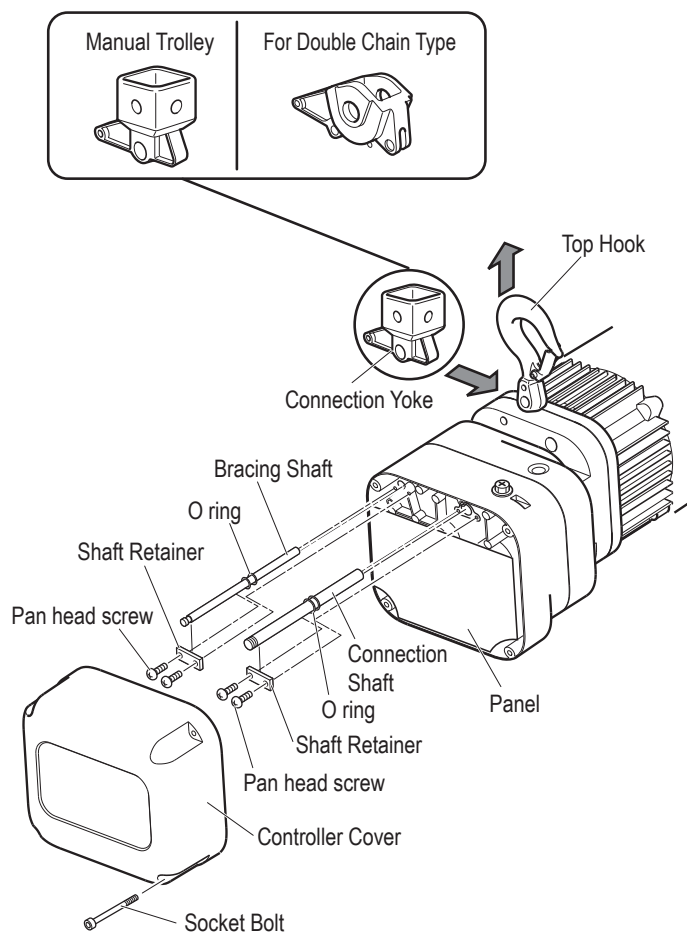

(to be continued)

Assembling (continued)

■ Checking the Number of the Assembled Adjusting Spacers and Their Positions

When installing a trolley to the beam, the length of the Suspension Shaft (width between frames) must be adjusted in accordance with the rail width. Wrong number of wrong position of Spacers may result in the drop of the electric chain hoist. Insert the correct number of Spacers with correct ratings and for rail width at the correct position, referring to the following table.

Beam flange width		Number of Adjusting Spacers																													
		(in)	2	2 ^{5/16}	2 ^{1/2}	2 ^{7/8}	3	3 ^{1/4}	3 ^{9/16}	3 ^{7/8}	3 ^{5/8}	4	4 ^{3/16}	4 ^{5/16}	4 ^{7/16}	4 ^{11/16}	4 ^{3/4}	4 ^{15/16}	5	5 ^{3/16}	5 ^{5/16}	5 ^{3/8}	5 ^{5/8}	5 ^{7/8}	6	6 ^{1/8}	6 ^{5/16}	6 ^{7/16}			
Capacity	Parts	(mm)	50	58	64	73	75	82	90	98	100	102	106	110	113	119	120	125	127	131	135	137	143	149	150	153	155	160	163		
		0.5	Thin spacer	Inner	2+3	3+4	0+1	1+2	2+2	3+3	0+1	1+2	2+2	2+3	1+1	1+2	2+2	3+3	0+0	0+1	1+1	1+2	2+2	2+2	3+3	0+0	0+1	1+1	1+2	2+2	2+2
Outer	4			2	8	6	5	3	8	6	5	4	7	6	5	3	9	8	7	6	5	3	9	8	7	6	5				
Thick spacer	Inner		0+0	0+0	1+1	1+1	1+1	1+1	2+2	2+2	2+2	2+2	0+0	0+0	0+0	0+0	1+1	1+1	1+1	1+1	1+1	1+1	1+1	1+1	2+2	2+2	2+2	2+2	2+2	2+2	
	Outer		4	4	2	2	2	2	0	0	0	0	7	7	7	7	5	5	5	5	5	5	5	3	3	3	3	3	3	3	3
Fixing spacer	Inner		-	-	-	-	-	-	-	-	-	-	1+1	1+1	1+1	1+1	1+1	1+1	1+1	1+1	1+1	1+1	1+1	1+1	1+1	1+1	1+1	1+1	1+1	1+1	
1	Thin spacer		Inner		3+3	0+0	1+1	1+2	2+3	0+0	1+1	1+2	2+2	2+3	3+4	0+1	1+2	2+2	1+1	1+2	1+1	1+2	2+2	3+3	0+0	0+1	1+1	1+1	1+1	1+2	2+2
		Outer		2	8	6	5	3	8	6	5	4	3	2	1	7	5	4	7	6	5	3	9	8	7	6	5				
	Thick spacer	Inner		0+0	1+1	1+1	1+1	1+1	2+2	2+2	2+2	2+2	2+2	2+2	2+2	3+3	3+3	3+3	0+0	0+0	0+0	0+0	0+0	1+1	1+1	1+1	1+1	1+1	1+1	1+1	1+1
		Outer		6	4	4	4	4	2	2	2	2	2	2	2	0	0	0	5	5	5	5	5	3	3	3	3	3	3	3	3
	Fixing spacer	Inner		-	-	-	-	-	-	-	-	-	-	-	-	-	-	-	-	1+1	1+1	1+1	1+1	1+1	1+1	1+1	1+1	1+1	1+1	1+1	
	2	Thin spacer	Inner						2+2	3+4	0+1	1+1	1+2	2+2	2+3	3+3	0+0	1+1	1+2	2+2	2+3	3+3	0+0	1+1	1+2	1+1	1+2	1+1	1+1	1+2	2+2
Outer								3	0	6	5	4	3	2	1	7	5	4	3	2	1	7	5	4	7	5	4	7	6	5	
Thick spacer		Inner						0+0	0+0	1+1	1+1	1+1	1+1	1+1	1+1	2+2	2+2	2+2	2+2	2+2	2+2	2+2	3+3	3+3	3+3	0+0	0+0	0+0	0+0	0+0	
		Outer						6	6	4	4	4	4	4	4	2	2	2	2	2	2	2	0	0	0	0	0	11	11	11	
Fixing spacer		Inner						-	-	-	-	-	-	-	-	-	-	-	-	-	-	-	-	-	-	-	1+1	1+1	1+1		
3		Thin spacer	Inner						1+2	3+3	0+0	0+1	1+1	1+2	2+2	2+3	3+4	0+1	1+1	1+2	2+2	2+3	3+4	1+4	1+5	1+1	1+2	1+2	2+2	2+2	
	Outer							7	4	10	9	8	7	6	5	3	9	8	7	6	5	3	5	4	7	6	5				
	Thick spacer	Inner						2+2	2+2	3+3	3+3	3+3	3+3	3+3	3+3	3+3	4+4	4+4	4+4	4+4	4+4	4+4	5+4	5+4	0+0	0+0	0+0	0+0	0+0		
		Outer						5	5	3	3	3	3	3	3	3	1	1	1	1	1	1	0	0	11	11	11				
	Fixing spacer	Inner						-	-	-	-	-	-	-	-	-	-	-	-	-	-	-	-	-	-	1+1	1+1	1+1			
	5	Thin spacer	Inner									0+0	0+1	1+1	1+2	2+2	3+3	0+0	0+1	1+1	1+2	2+2	3+3	0+0	0+1	1+2	1+2	2+2	2+2	2+2	
Outer												8	7	6	5	4	2	8	7	6	5	4	2	8	7	6	5	4			
Thick spacer		Inner										0+0	0+0	0+0	0+0	0+0	0+0	1+1	1+1	1+1	1+1	1+1	1+1	1+1	2+2	2+2	2+2	2+2	2+2		
		Outer										5	5	5	5	5	5	3	3	3	3	3	3	3	1	1	1	1	1		
Fixing spacer		Inner																													

		Number of Adjusting Spacers																												
Beam flange width		(in)	6 ^{11/16}	6 ^{7/8}	7	7 ^{1/16}	7 ^{1/4}	7 ^{1/8}	8	8 ^{7/16}	8 ^{11/16}	9	9 ^{1/8}	9 ^{7/8}	10	10 ^{1/8}	10 ^{1/4}	10 ^{3/8}	10 ^{1/2}	11	11 ^{1/8}	11 ^{1/4}	11 ^{3/8}	11 ^{5/8}	11 ^{3/4}	11 ^{13/16}	11 ^{7/8}	12		
Capacity	Parts	(mm)	170	175	178	180	184	181	185	200	203	215	220	229	232	250	254	257	260	264	267	279	283	286	289	295	298	300	302	305
0.5	Thin spacer	Inner	3+3	0+0	0+1	1+1	1+2	4+4	4+5	2+3	3+3	4+5	1+1	0+0	0+1	1+1	1+2	2+2	2+3	4+5	1+1	1+2	2+2	3+3	3+4	4+4	4+5	1+5		
		Outer	3	9	8	7	6	1	0	4	3	0	7	9	8	7	6	5	4	0	7	6	5	3	2	1	0	3		
	Thick spacer	Inner	2+2	3+3	3+3	3+3	3+3	3+3	0+0	0+0	0+0	1+1	2+2	2+2	2+2	2+2	2+2	2+2	2+2	2+2	3+3	3+3	3+3	3+3	3+3	3+3	3+3	4+3		
		Outer	3	1	1	1	1	1	1	1	7	7	7	5	3	3	3	3	3	3	3	1	1	1	1	1	1	1	0	
	Fixing spacer	Inner	1+1	1+1	1+1	1+1	1+1	1+1	1+1	1+1	1+1	1+1	1+1	1+1	1+1	1+1	1+1	1+1	1+1	1+1	1+1	1+1	1+1	1+1	1+1	1+1	1+1	1+1	1+1	
	1	Thin spacer	Inner	3+3	0+0	0+1	1+1	1+2	4+4	4+5	2+3	3+3	4+5	1+1	0+0	0+1	1+1	1+2	2+2	2+3	4+5	1+1	1+2	2+2	3+3	3+4	4+4	4+5	1+5	
Outer			3	9	8	7	6	1	0	4	3	0	7	9	8	7	6	5	4	0	7	6	5	3	2	1	0	3		
Thick spacer		Inner	1+1	2+2	2+2	2+2	2+2	2+2	0+0	0+0	0+0	1+1	2+2	2+2	2+2	2+2	2+2	2+2	2+2	2+2	3+3	3+3	3+3	3+3	3+3	3+3	3+3	4+3		
		Outer	3	1	1	1	1	1	1	7	7	7	5	3	3	3	3	3	3	3	1	1	1	1	1	1	1	1	0	
Fixing spacer		Inner	1+1	1+1	1+1	1+1	1+1	1+1	1+1	1+1	1+1	1+1	1+1	1+1	1+1	1+1	1+1	1+1	1+1	1+1	1+1	1+1	1+1	1+1	1+1	1+1	1+1	1+1	1+1	
2		Thin spacer	Inner	3+3	0+0	0+1	1+1	1+2	0+0	0+1	2+3	3+3	4+5	1+1	0+0	0+1	1+1	1+2	2+2	2+3	4+5	1+1	1+2	2+2	3+3	3+4	4+4	4+5	1+5	
	Outer		3	9	8	7	6	9	8	4	3	0	7	9	8	7	6	5	4	0	7	6	5	3	2	1	0	3		
	Thick spacer	Inner	0+0	1+1	1+1	1+1	1+1	2+2	2+2	2+2	2+2	2+2	3+3	4+4	4+4	4+4	4+4	4+4	4+4	4+4	5+5	5+5	5+5	5+5	5+5	5+5	5+5	6+5		
		Outer	11	9	9	9	9	7	7	7	7	7	5	3	3	3	3	3	3	3	1	1	1	1	1	1	1	1	0	
	Fixing spacer	Inner	1+1	1+1	1+1	1+1	1+1	1+1	1+1	1+1	1+1	1+1	1+1	1+1	1+1	1+1	1+1	1+1	1+1	1+1	1+1	1+1	1+1	1+1	1+1	1+1	1+1	1+1	1+1	
	3	Thin spacer	Inner	3+3	0+0	0+1	1+1	1+2	0+0	0+1	2+3	3+3	4+5	1+1	0+0	0+1	1+1	1+2	2+2	2+3	4+5	1+1	1+2	2+2	3+3	3+4	4+4	4+5	1+5	
Outer			3	9	8	7	6	9	8	4	3	0	7	9	8	7	6	5	4	0	7	6	5	3	2	1	0	3		
Thick spacer		Inner	0+0	1+1	1+1	1+1	1+1	2+2	2+2	2+2	2+2	2+2	3+3	4+4	4+4	4+4	4+4	4+4	4+4	4+4	5+5	5+5	5+5	5+5	5+5	5+5	5+5	6+5		
		Outer	11	9	9	9	9	7	7	7	7	7	5	3	3	3	3	3	3	3	1	1	1	1	1	1	1	1	0	
Fixing spacer		Inner	1+1	1+1	1+1	1+1	1+1	1+1	1+1	1+1	1+1	1+1	1+1	1+1	1+1	1+1	1+1	1+1	1+1	1+1	1+1	1+1	1+1	1+1	1+1	1+1	1+1	1+1	1+1	
5		Thin spacer	Inner	3+3	0+4	1+4	1+1	1+2	0+0	0+1	2+3	3+3	0+1	1+1	0+0	0+1	1+1	1+2	2+2	2+3	0+1	1+1	1+2	2+2	3+3	3+4	4+4	1+4	1+5	
	Outer		2	4	3	6	5	8	7	3	2	7	6	8	7	6	5	4	3	7	6	5	4	2	1	0	3	2		
	Thick spacer	Inner	2+2	3+2	3+2	0+0	0+0	1+1	1+1	1+1	1+1	2+2	2+2	3+3	3+3	3+3	3+3	3+3	3+3	4+4	4+4	4+4	4+4	4+4	4+4	4+4	5+4	5+4		
		Outer	1	0	0	9	9	7	7	7	7	5	5	3	3	3	3	3	3	1	1	1	1	1	1	1	0	0		
	Fixing spacer	Inner	-	-	-	1+1	1+1	1+1	1+1	1+1	1+1	1+1	1+1	1+1	1+1	1+1	1+1	1+1	1+1	1+1	1+1	1+1	1+1	1+1	1+1	1+1	1+1	1+1		

NOTE) 1) Take note the numbers on spacers of inner side as follows.

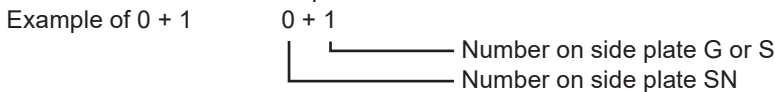

2) Adjustment of trolley width

See clause 3-3.

Adjust the dimensions by appropriately increasing or decreasing the number of inner or outer adjusting spacers, without strictly adhering to the number in the above table.

3) The spacers are delivered in different colors as follows:

Type A: Thick Spacer and Thin Spacer in yellow, and Fixing Spacer in white

Type B: Thick Spacer and Thin Spacer in white, and Fixing Spacer in black

3) A indicates standard range.

B indicates W20 range, as option

C indicates W30 range, as option

(m)	4	5	6	7	8
0.5					
1				(B)	
2	(A)				(C)
3					
5					

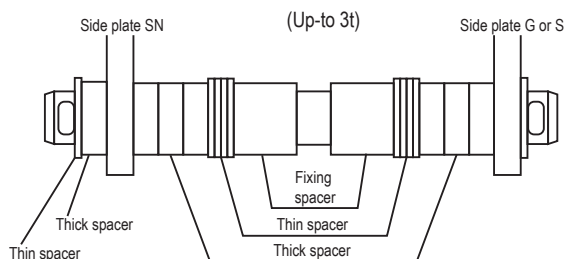

(to be continued)

Assembling (continued)

■ Combination of the Electric Chain Hoist and the Manual Trolley

DANGER

Mandatory

- Use new split pins. After insertion, bend the pin securely at its both ends.

Use of old split pins may result in death or serious injury due to drop.

● 125 kg~2.5 t

1) After setting the Suspension Shaft with Spacers, insert it into Frame G or Frame S and fix it with a Shaft Stopper Pin and a Split Pin.

- Insert the Shaft Stopper Pin in the direction that the split pin comes to the right when viewed from the side of the Frame G or Frame S.
- Open the both ends of the Split Pin by 70° or more.

2) Set the Suspension Shaft with a Thin Spacer, Thick Spacer and Fixing Spacer.

3) Set the Suspender with the Suspension Shaft.

4) Set the Suspension Shaft with another Thin Spacer, Thick Spacer and Fixing Spacer. Then insert the Suspension Shaft into the Frame SN.

- Adjust the Spacers in accordance with the rail width. (Refer to "Checking the Number of the Assembled Adjusting Spacers and Their Positions" (P48) for the number of Spacers.)

5) Set the Suspension Shaft with a Thick Spacer. Fix it with a Shaft Stopper Pin and a split pin.

- Insert the Shaft Stopper Pin in the direction that the split pin comes to the right when viewed from the front side of the Frame SN.
- Open the both ends of the Split Pin by 70° or more.

6) Mount the Suspender to the Connection Yoke with a Yoke Bolt, a slotted nut and a split pin.

Note:

When connecting the Suspender and Connection Yoke, the insertion direction of the Yoke Bolt is different according to the types of the manual trolleys to connect with. (See the figures in the right.)

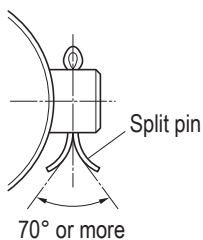
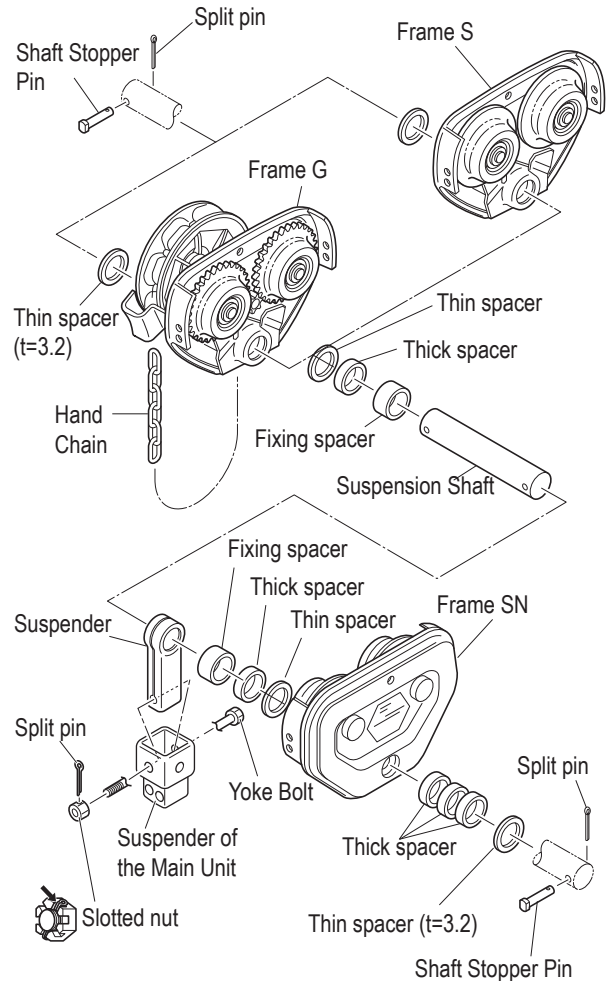

Bending the split pin

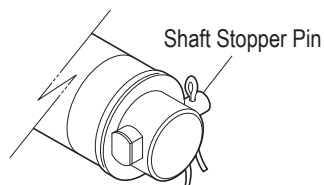

Orientation of Shaft Stopper Pin

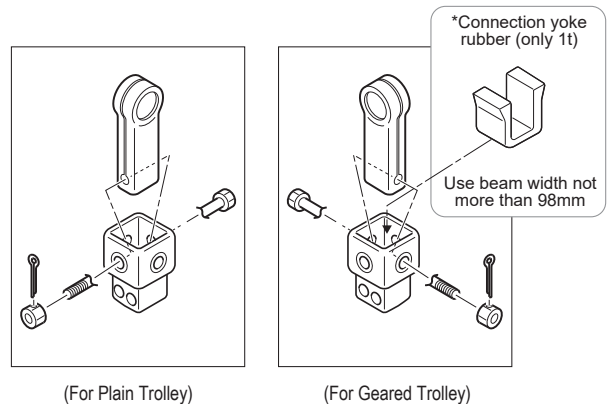

(For Plain Trolley)

(For Geared Trolley)

*Use connection yoke rubber when the beam width is not more than in not more than 98mm by combining geared trolley TSG.

● 3 t~5 t (For Double Chain type)

1) Fix the Suspension Shaft to the Frame G or the Frame S with a Suspension Shaft Bolt, a slotted nut and a split pin.

- When fixing the Frame G or the Frame S to the Suspension Shaft, use the hole for standard rail width. Use the hole for rail width 175 mm or 190 mm for one stage up rail width. Open the both ends of the split pin by 70° or more.
- Attach the split pin to the right side when viewed from the Frame G or the Frame S.
- Open the both ends of the split pin by 70° or more.

2) Set the Suspension Shaft with a Thin Spacer, Thick Spacer and Fixing Spacer.

3) Set the Suspender with the Suspension Shaft.

4) Set the Suspension Shaft with another Thin Spacer, Thick Spacer and Fixing Spacer. Then insert the Suspension Shaft into the Frame SN.

- Adjust the Spacers in accordance with the rail width. (Refer to "Checking the Number of the Assembled Adjusting Spacers and Their Positions" (P48) for the number of Spacers.)

5) Set the Suspension Shaft with a Thick Spacer. Fix it with a Shaft Stopper Pin and a split pin.

- Insert the Shaft Stopper Pin in the direction that the split pin comes to the right when viewed from the front side of the Frame SN.
- Open the both ends of the Split Pin by 70° or more.

6) Mount the Suspender to the Connection Yoke with a Yoke Bolt, a slotted nut and a split pin.

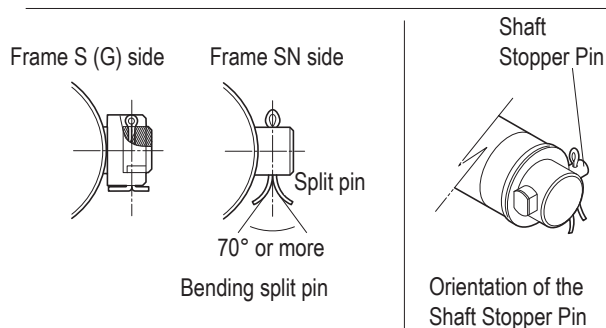
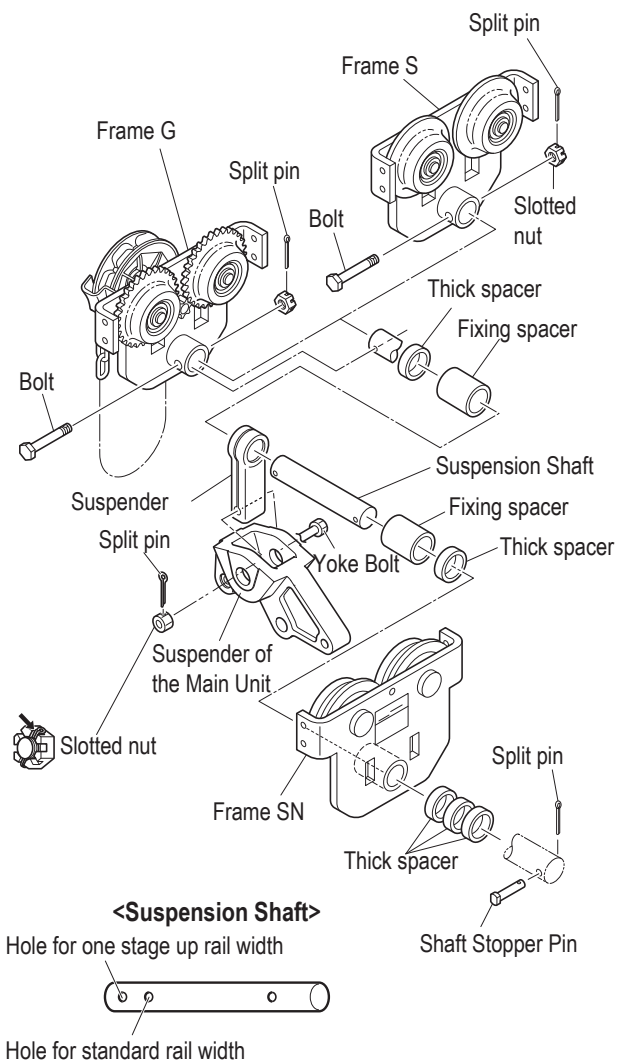

(to be continued)

Assembling (continued)

■ Checking Power and Power Cable

DANGER

Mandatory

- Check that the rating of the breaker satisfies the specification required by the electric chain hoist.
- Check that the source voltage satisfies the rated voltage of the electric chain hoist.
- Use a breaker with a capacity in conformance with the product specifications.

Failure to comply with this instruction may result in death or serious injury.

■ Checking the Power

- Hook suspended Type:ER2
Manual Trolley type:ER2SP/ER2SG

Code	Capacity of fuse and circuit breaker (A)		
	Wire size (mm ²)	220/440V Class	
		Single speed	Dual speed
ER2-001H/HH	AWG16	5/5	5/5
ER2-003S/IS			
ER2-005L/IL			
ER2-005S/IS		10/5	10/5
ER2-010L/IL			
ER2-010S/IS			
ER2-015S/IS	AWG14	15/10	15/10
ER2-020L/IL			
ER2-020S/IS			
ER2-025S/IS		30/10	30/15
ER2-030S/IS			
ER2-050S/IS			

Code	Wire size (mm ²)	Capacity of fuse and circuit breaker (A)	
		500V Class	
		Single speed	Dual speed
ER2-001H/HD	1.25	5	5
ER2-003S/SD			
ER2-005L/LD			
ER2-005S/SD			
ER2-010L/LD			
ER2-010S/SD			
ER2-015S/SD	2	10	10
ER2-020L/LD			
ER2-020S/SD			
ER2-025S/SD			
ER2-030S/SD			
ER2-050S/SD			

- Motorized Trolley type:ER2M

Code	Capacity of fuse and circuit breaker (A)		
	Wire size (mm ²)	220/440V Class	
		ER Single MR Single	ER Dual MR Dual
ER2-001H/HH	AWG14	10/5	10/5
ER2-003S/IS			
ER2-005L/IL			
ER2-005S/IS		15/10	15/10
ER2-010L/IL			
ER2-010S/IS			
ER2-015S/IS	AWG12	20/10	20/10
ER2-020L/IL			
ER2-020S/IS			
ER2-025S/IS		30/15	30/15
ER2-030S/IS			
ER2-050S/IS			

Code	Wire size (mm ²)	Capacity of fuse and circuit breaker (A)	
		500V Class	
		ER Single MR Single	ER Dual MR Dual
ER2-001H/HD	2	5	5
ER2-003S/SD			
ER2-005L/LD			
ER2-005S/SD			
ER2-010L/LD			
ER2-010S/SD			
ER2-015S/SD	3.5	10	10
ER2-020L/LD			
ER2-020S/SD			
ER2-025S/SD			
ER2-030S/SD			
ER2-050S/SD			

■ Checking the Power Cable

CAUTION

Mandatory

- Satisfy the maximum permissible length and core cross section of the Power Cable.

Failure to comply with this instruction causes bodily injury or loss of property.

Refer to the following table for the permissible length and the size of the standard Power Cable.

When using the cable of the size other than those described in the table, decide the cable length using the following formula.

$$\text{Permissible length (m)} = \frac{1000}{30.8} \times \frac{\text{Cross section of one core (mm}^2\text{)} \times \text{Rated voltage (V)} \times 0.02}{\text{Rated current (A)}}$$

● Hook suspended Type:ER2
Manual Trolley type:ER2SP/ER2SG

Code	220/440V Class (Unit: m)					500V Class (Unit: m)			
	Wire size (mm ²)	Single speed		Dual speed		Code	Wire size (mm ²)	Single speed	Dual speed
		60Hz		60Hz				60Hz	60Hz
		220-230V	415-440V	220-230V	415-440V			575V	575V
ER2-001H/HH	AWG16 (AWG14)	49	197	46	186	ER2-001H/HD	1.25 (2)	253	253
ER2-003S/IS		(79)	(316)	(74)	(298)	ER2-003S/SD		(405)	(405)
ER2-005L/IL						ER2-005L/LD			
ER2-005S/IS		35	134	33	124	ER2-005S/SD		202	225
ER2-010L/IL		(56)	(215)	(52)	(199)	ER2-010L/LD		(324)	(360)
ER2-010S/IS		19	80	18	74	ER2-010S/SD		135	126
ER2-015S/IS		(31)	(128)	(29)	(119)	ER2-015S/SD		(216)	(202)
ER2-020L/IL	AWG14 (AWG12)					ER2-020L/LD			
ER2-020S/IS		16	68	15	64	ER2-020S/SD	108	108	
ER2-025S/IS		(28)	(119)	(27)	(113)	ER2-025S/SD	(189)	(189)	
ER2-030S/IS						ER2-030S/SD			
ER2-050S/IS						ER2-050S/SD			

● Motorized Trolley type:ER2M

Code	500V Class (Unit: m)					220/440V (Class230/460V Class) (Unit: m)									
	Wire size (mm ²)	ER single	ER dual	ER dual	ER single	Code	Wire size (mm ²)	ER single		ER dual		ER dual		ER single	
		MR single	MR dual	MR single	MR dual			MR single		MR dual		MR single	MR dual		
		60Hz	60Hz	60Hz	60Hz			60Hz		60Hz		60Hz	60Hz		
		575V						220V	440V	220V	440V	220V	440V	220V	440V
ER2-001H/HD	2 (3.5)	209	196	209	196	ER2-001H/HH	AWG14 (AWG12)	40	163	38	153	39	158	39	158
ER2-003S/SD		(365)	(346)	(365)	(343)	ER2-003S/IS		(71)	(285)	(67)	(268)	(69)	(276)	(69)	(276)
ER2-005L/LD						ER2-005L/IL									
ER2-005S/SD		185	185	196	175	ER2-005S/IS		33	131	31	122	32	125	32	128
ER2-010L/LD		(324)	(324)	(343)	(306)	ER2-010L/IL		(59)	(229)	(55)	(213)	(56)	(218)	(57)	(224)
ER2-010S/SD		144	132	137	137	ER2-010S/IS		22	92	31	86	21	88	22	91
ER2-015S/SD		(252)	(231)	(241)	(241)	ER2-015S/IS		(40)	(162)	(37)	(151)	(38)	(154)	(39)	(159)
ER2-020L/LD					ER2-020L/IL										
ER2-020S/SD	3.5 (5.5)	151		151		ER2-020S/IS	24	99	22	94	23	95	23	98	
ER2-025S/SD		(237)	143	(237)	143	ER2-025S/IS	(37)	(155)	(35)	(147)	(36)	(149)	(37)	(154)	
ER2-030S/SD		138	(225)	138	(225)	ER2-030S/IS	21	90	20	85	21	87	21	88	
ER2-050S/SD		(217)		(217)		ER2-050S/IS	(34)	(142)	(32)	(134)	(33)	(137)	(34)	(139)	

(to be continued)

Assembling (continued)

■ Connecting Cables

NOTE

- When tightening a connector, do not use tools. Be sure to tighten it by hand.
Excessive tightening of the connector may cause damage to the plastic screw threads or result in cable breakage.
- To prevent wire breakage and unintentional removal of a connector, tie the strain relief wire attached to the Push Button Switch Cord to the body of the electric chain hoist or the trolley.
- Be sure to turn off the power when carrying out the repair work of wire breakage or removal of the connector.

■ Hook suspended model (hoist only)

■ 125 kg~5 t

● Connecting the Power Cable

- 1) Insert the 4-pin plug of the Power Cable to the socket (4P) and tighten the Lock Ring securely.

- 2) Fix the Power Cable using cable support with a slack.

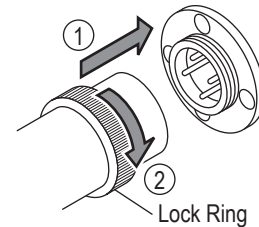

● Connecting the Push Button Switch Cord

- 1) Insert the 8-pin connector plug of the Push Button Cord to the connector socket (8P) and tighten the Lock Ring securely.

- 2) Pass the Cable Support L into the ring at the end of the Protection Wire. Put the Protection Wire or Chain in the notch of the Cable Support L. Then fix the Cable Support L to the body (at the bottom face of the Gear Case).

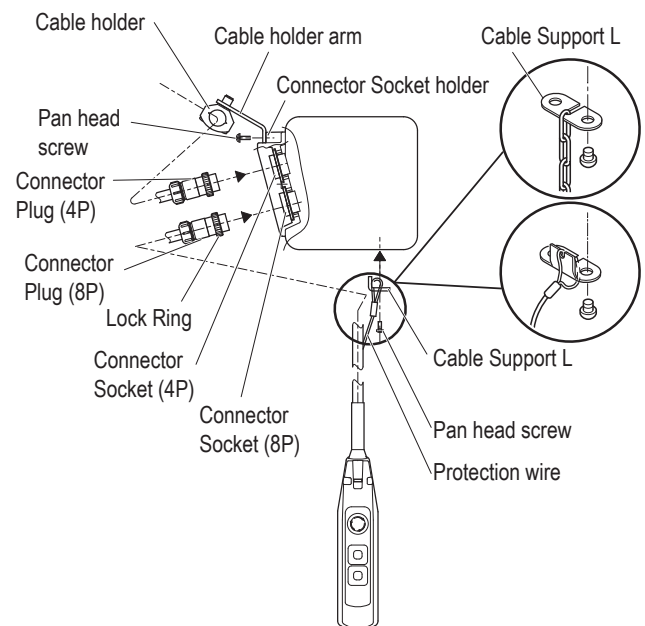

■ Motorized Trolley Type

■ 125 kg~5 t

● Connecting the relay cable

- 1) Insert the connector plug (4P) of relay cable for power supply in the connector socket (4P) of ER2. Tighten the Lock Ring securely.
- 2) Insert the connector plug (8P) of relay cable for operation in the connector socket (8P) of ER2. Tighten the Lock Ring securely.

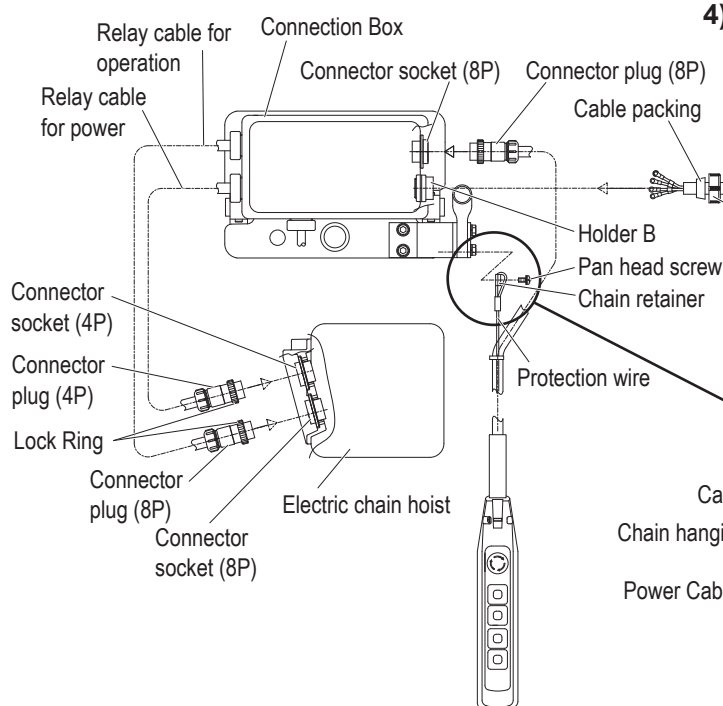

● Connecting the Power Cable

- 1) Remove the Holder A mounted to the Connection Box.
- 2) Pass the Power Cable through the Holder A supported by the cable holder and the cable packing.
- 3) Insert the Power Cable to the Holder B of the Connection Box and tighten the Holder A securely.
 - Trolley Type
 - 1) Mount the cable holder, which the Power Cable is passed, to the cable holder arm using a chain hanging pin B, a slotted nut and a split pin.
- 4) Connect the Power Cable to the terminal panel of the Connection Box.
 - Connect wires correctly according to the wiring diagram affixed on the Connection Box.

<Trolley Power Cable Connection>

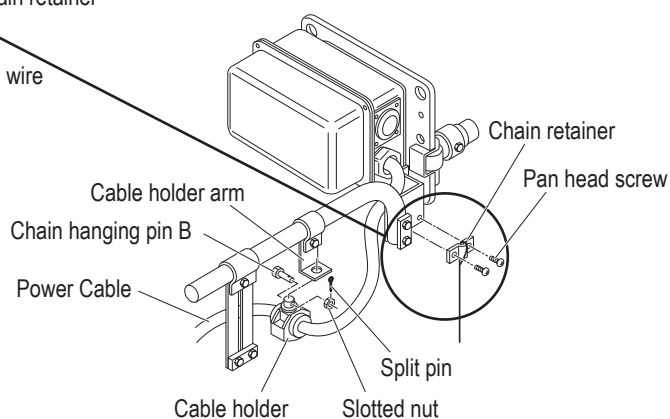

● Connecting the Push Button Switch Cord

- 1) Insert the connector plug (8P) of Push Button Switch Cord in the connector socket (8P). Tighten the Lock Ring securely.
- 2) Pass the Chain retainer into the hoop at the end of the Protection Wire and fix it to the bar holder with a pan head screw.

(to be continued)

Assembling (continued)

Manual Trolley Type

125 kg~5 t

Connecting the Power Cable

- 1) Insert the 4-pin plug of the Power Cable to the socket (4P) and tighten the Lock Ring securely.

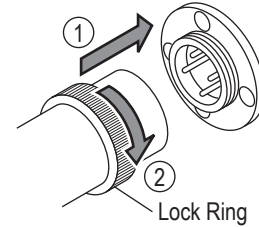

- 2) Fix the Power Cable using cable support with a slack.

Connecting the Push Button Switch Cord

- 1) Insert the 8-pin connector plug of the Push Button Cord to the connector socket (8P) and tighten the Lock Ring securely.

- 2) Pass the Cable Support L into the ring at the end of the Protection Wire. Put the Protection Wire in the notch of the Cable Support L. Then fix the Cable Support L to the body (at the bottom face of the Gear Case).

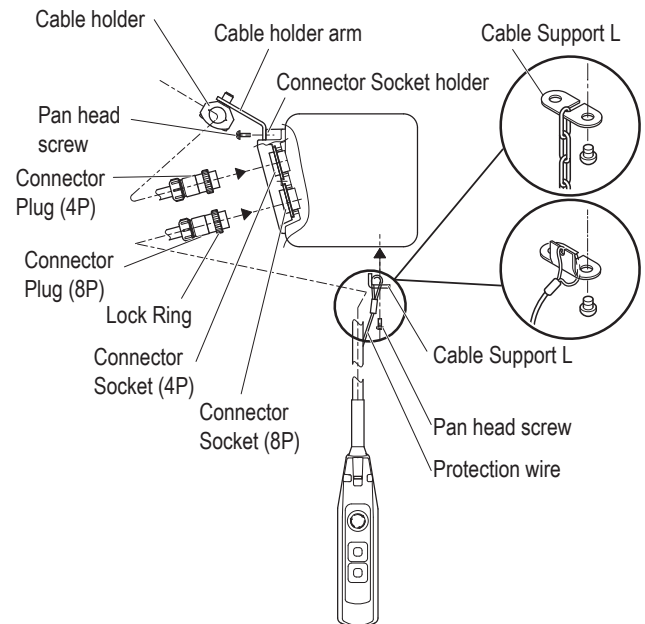

Installation

⚠ DANGER



Prohibited

- **Installation (removal) of the electric chain hoist must be carried out by special installer or by personnel with expertise.** Consult with the sales shop or KITO for installation, or consign the installation work to special installer or personnel with expertise.
- **Do not install the electric chain hoist at a place exposed to rain or water always or the place different from the Operational Environment (P18).**
- **Do not install the electric chain hoist in the motion space of other trolley or any other moving equipment (facility).**
- **Do not use the electric chain hoist contacting with other object, or being fixed.**

Failure to comply with these instructions may result in death or serious injury.



Mandatory

- When installing or removing the electric chain hoist, follow the instructions in Owner's Manual.
- Carry out the work for grounding (earthing) and installation of earth leakage breaker with higher harmonic countermeasures.
- When the installation is completed, carry out "Check after Installation". (See P61)
- Connect the power after all installation works have been completed and just before the operation check.
- Mount the stopper at the both ends of the travel rail for trolley. <Fig. A>
- Make sure that the strength of the structure is sufficient to install the electric chain hoist.
- Carry out the installation work after securing the stable foothold.
- When not using the KITO Standard Trolley and use the Electric Chain Hoist incorporated as part of your travel device, make sure to contact KITO for precautions.

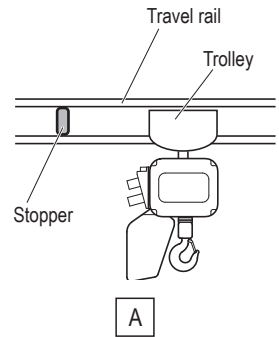

Failure to comply with these instructions may result in death or serious injury.

⚠ CAUTION



Mandatory

- **Connect the Power Cable to the power of rated voltage.**
- Failure to comply with this instruction causes bodily injury or loss of property.

■ Connecting Power and Power Cable

When connecting the Power Cable to the power, connect the cable in accordance with the following instructions.

- Connect the electric chain hoist to the power through a breaker.
- Connect the electric chain hoist in the correct phase.
(When 'Check after Installation (P61)' is completed, carry out the operation check for the correct phase.)
- Earth wire is a green colored covered cable with yellow line. Carry out Class D earthing work.
- Use correct breaker and Power Cable referring to Checking the Power and the Power Cable (P52) for the breaker capacity, Power Cable length and its size.

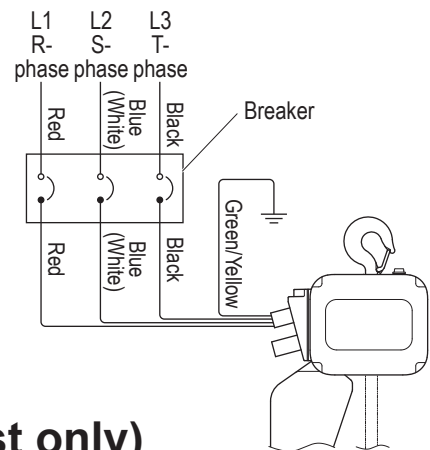

■ Installing the Hook Suspended Type (hoist only)

■ Checking Installation Method and Place

⚠ DANGER



Mandatory

- When using an electric chain hoist suspended (as a single unit) without combination with a trolley, make sure that the Hook Latch of the Top Hook closes securely.
- Make sure that the Top Hook and body can swing freely. Do not restrain the Top Hook and body during use.
- Do not install and use the electric chain hoist upside down.

Failure to comply with these instructions may result in death or serious injury.

(to be continued)

Installation (continued)

■ Installing the Trolley Combined Model

■ Mounting the Hoist to the Travel Rail

- 1) Make sure that the dimensions of the Trolley Frame satisfy the size of the rail to which the trolley is installed.
- 2) Make sure that the rail is set to a level.
- 3) Install the electric chain hoist combined with the trolley to the rail from its one end

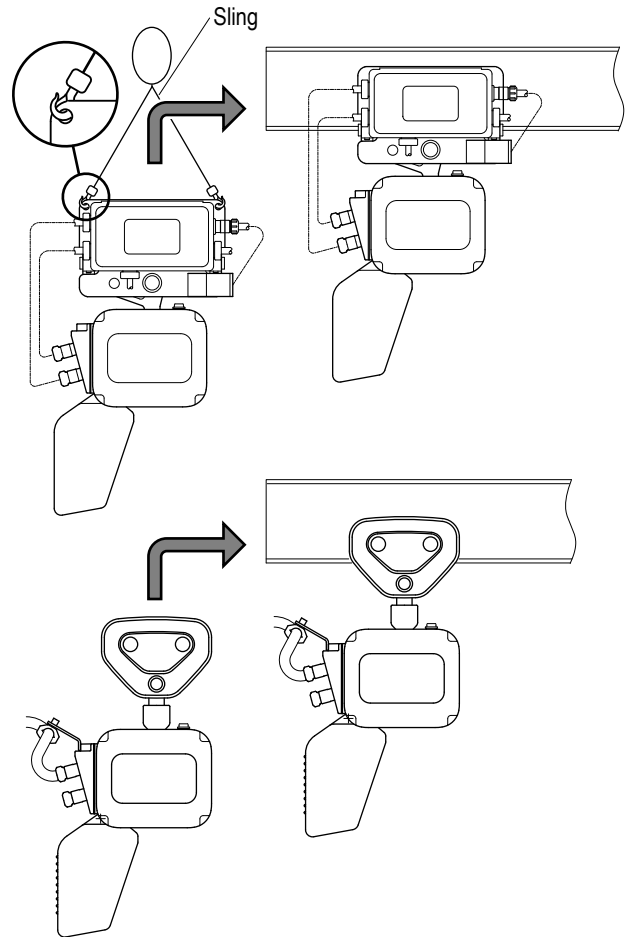

● If the trolley cannot be installed from the end of the rail:

- 1) Assemble the Trolley temporarily using the hole B of the Suspension Shaft and install the electric chain hoist from the bottom side of the Travel Rail.
- 2) Set the wheel at G side of the Trolley Frame on the running face of the Travel Rail. Then push the Frame S into the Frame G.
- 3) Insert the Shaft Stopper Pin into the Hole A of the Suspension Shaft. Then mount a split pin securely.

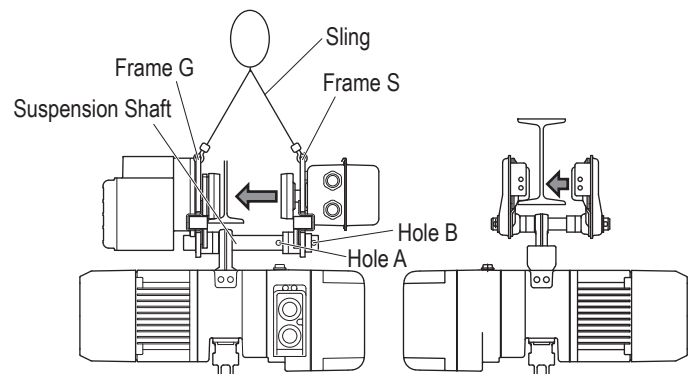

■ Mounting the Stopper

Be sure to mount the stoppers at the both ends of the rail to prevent drop.

Decide the mounting position in accordance to the size of the wheel.

When the customer wants to make the stopper by oneself, refer to the following figures.

For the stopper position of the hoist with steel chain container, please refer to the steel chain container installation manual.

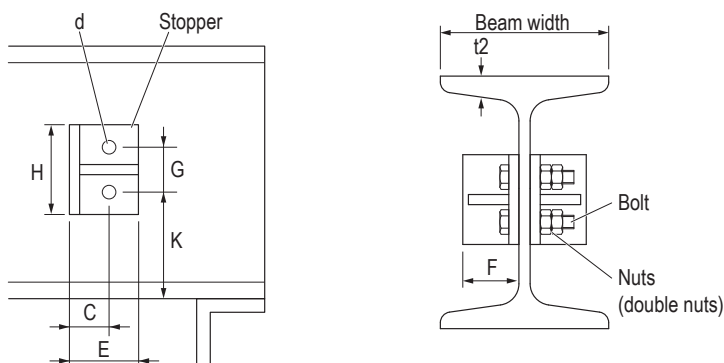

(Unit: mm)

Capacity	~2t				2.5t~5t		
Beam width	100	125	150	175	125	150	175
Material dimensions	L-50x50x6	L-50x50x6	L-65x65x8	L-75x75x9	L-50x50x6	L-65x65x8	L-75x75x9
H	80	80	80	80	100	100	100
E	50	50	65	75	50	65	75
F	40	50	65	75	50	65	75
G	50	50	50	50	60	60	60
C	30	30	35	40	30	35	40
K	65	t2+50	t2+50	t2+50	t2+60	t2+60	t2+60
d	φ14	φ14	φ14	φ14	φ18	φ18	φ18
Bolt size	M12x50x50	M12x55x55	M12x55x55	M12x60x60	M16x65x65	M16x65x65	M16x65x65

NOTE) Dimension K is for the case to use combining the hoist with the motorized trolley. When using the hoist combined with a manual trolley, mount the stopper in accordance with the bumper position.

● When using T-shape cable hanger

Install the additional stopper for T-shape cable hanger at the end of one rail.

When using T-shape cable hanger, the suspender pusher needs to be mounted to the trolley.

For the manual trolley, machine the holes shown in the table below for attaching the suspender pusher.

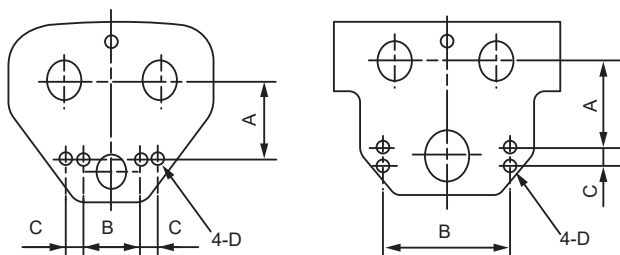

Capacity	up to 0.5t	up to 1t	up to 2t	up to 3t	up to 5t
TSP	○				
TSG		○	○	○	○
A	62	75	86	93.5	142
B	50	80	80	124	242
C	15	15	22	22	19
D	M5	M5	M5	M5	φ8.5

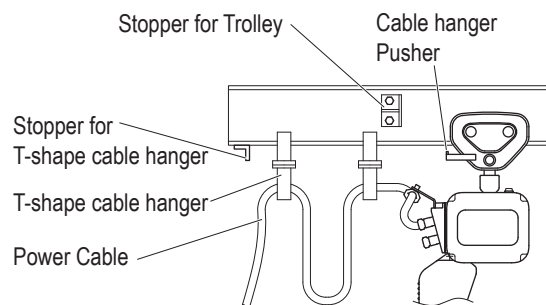
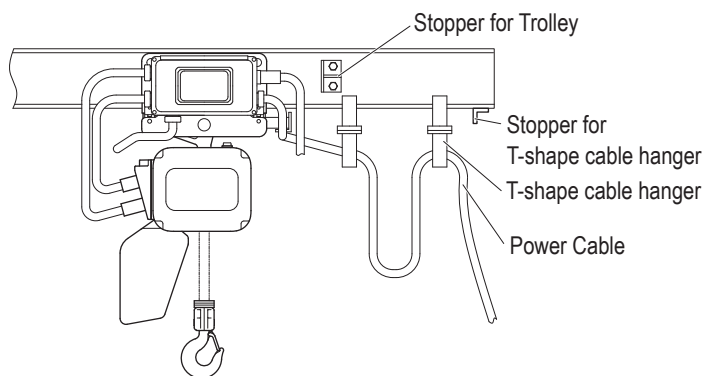

(to be continued)

Installation (continued)

Power Cable Layout for Motorized/Manual trolley type

- In the standard specification the Suspender is provided. T-shape cable hanger and angle type Suspender are also available as optional parts. T-shape cable hanger can be applicable to curved rail, however, the application method differs depending on the condition such as radius of curvature. In such case, contact KITO.

1) Mount the wire support bar at the both ends of the rail.

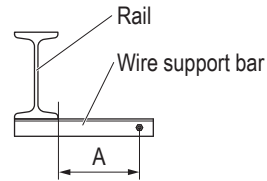

2) Tie the Messenger Wire passed through the Cable Hanger to the Wire Support Bar with two Wire Bolts.

- The recommended mounting interval of the Cable Hangers is 1.5 m to 2 m.
- Use steel wire of 3 to 6 mm in diameter for the Messenger Wire.

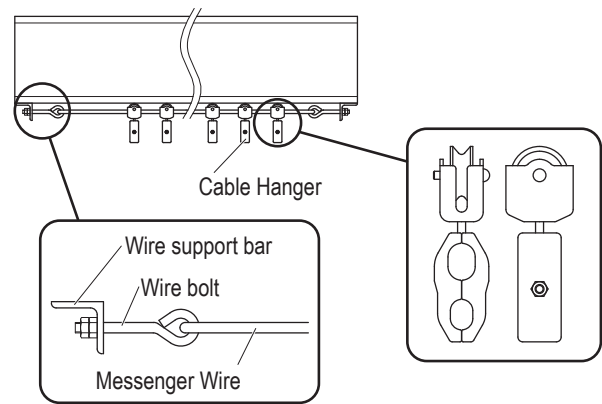

3) Loosen two pan head screws and remove the end clip of the wire guide.

4) Pass the Messenger Wire through the groove of the messenger guide. Mount the end clip with two pan head screws.

- The dimension A between the side face of the rail and the groove of the wire guide must be same as that of mounting hole of the Wire support bar for the Messenger Wire and the side face of the rail.

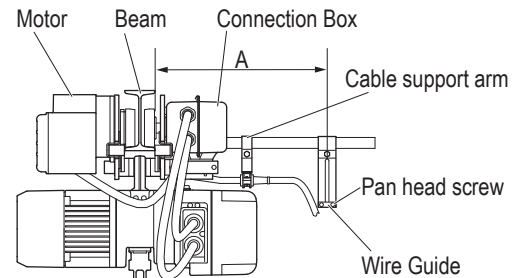

5) Fix the Power Cable to the Cable Hanger.

6) Mount the Cable Support to the Cable Support Arm.

7) Insert the Power Cable into the Connection Box of MR2 and connect it to the terminal panel.

- Connect wires correctly according to the wiring diagram affixed on the Connection Box.

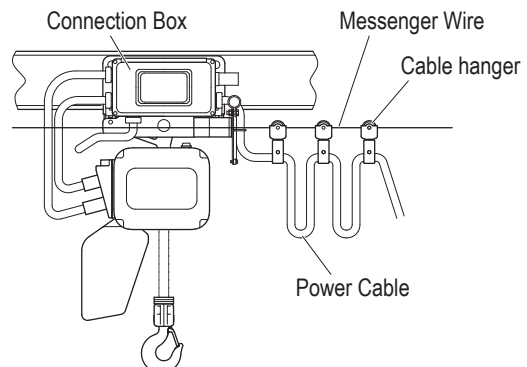

Check after Installation

Wrong assembling or installation causes death or serious injury. To prevent such danger check the following.

■ Check items

Make sure that the following are satisfied:

- No bolt, nut nor split pin is lost. Tightening and assembling are completed.
- Protection Wire for Push Button Switch Cord is securely tied to accept and endure the force instead of Push Button Switch Cord when the Push Button Switch Set is drawn.
- The Power Cable is fixed to the Cable Support.
- Source voltage is the rated voltage
- Grounding Wire (earth wire) is connected securely.

● When using with a Trolley

Check the following:

- The electric chain hoist and the trolley are combined correctly.
- The stoppers for trolley are securely mounted to Travel Rail where the Trolley travels.
- The surface of Travel Rail is not attached with paint or oil. (The surface of the Travel Rail must be base metal. Do not paint.) There is no obstacle for the trolley to travel. The Travel Rail is set to a level.)

■ Operational Check

Check the operation according to the procedures described in "■Function and Performance" under "Daily Inspection" (pages 32, 34, and 35).

<Memo>

A series of horizontal dotted lines for writing a memo.

Chapter 2

Inspection

This chapter describes monthly inspection items and annual inspection items. Refer to Chapter 1 for the “Handling the Product”. Inspection is the first step of safety. Carry out daily inspection, monthly inspection and annual inspection.

Table of Contents

■ Safety Precautions 66

■ Monthly Inspection

■ Electric Chain Hoist

Load Chain

Elongation of Pitch	69
Abrasion of wire diameter	69

Top Hook, Bottom Hook

Opening and Abrasion of the Hook	70
Deformation, Flaw, Corrosion	70

Peripheral parts of the Body

Chain Container	71
-----------------------	----

Push Button Switch

Push Button Switch Body	72
Push Button Switch Cord	72

Power Supply

Power Cable	73
Cable Hanger	73
Messenger Wire	73

Function and Performance

Abnormal Noise	73
----------------------	----

■ Motorized Trolley

Travel Rail (Recommendation)

Appearance	74
------------------	----

Push Button Switch, Power Supply 74

Connection Status

Connection parts	74
------------------------	----

■ Manual Trolley

Travel Rail (Recommendation)

Appearance	74
------------------	----

Connection Status

Connection parts	74
------------------------	----

■ Annual Inspection

■ Electric Chain Hoist

Check of the Operation History

Operating Hours and Number of Starts	76
--	----

Peripheral parts of the Body

Chain Guide A	76
Chain Spring	77
Stopper	77
Limit Lever	77
Chain Pin (double type only)	78
Connection Yoke D (double type only)	78
Shaft Retainer Clip	78

Gear Box (Gear case, Body)

Appearance	78
Oil Leakage	78
Oil amount and stain	78

Electromagnetic Brake

Appearance	79
Gap	79
Hub Joint	79
V ring	79

Electrical Equipment

Electrical Parts	80
Wiring	80
Contamination and attachment of foreign matter ...	80
VFD	80

Electric Characteristics Measurement

Source Voltage	80
Insulation Resistance (For crane use)	80
Grounding Resistance (For crane use)	81

Function and Performance

Operational Check	81
Brake	81

■ Annual Inspection

■ Motorized Trolley

Brake

Appearance	84
Abrasion of Brake Pad.....	84

Body Components

Wheel	84
Side Roller	84
Suspension Shaft	85
Suspender	85
Gear Frame Packing	85

Lubrication

Gearing part of the wheel and drive gear	85
--	----

Travel Rail (Recommendation)

Rail Surface	86
Deformation and Abrasion	86
Rail Mounting Bolt	86
Stopper	86

Relay Cable

Appearance	86
------------------	----

Electrical Equipment and Electric Characteristics ... 86

Function and Performance

Operational Check	87
Brake	87
Abnormal Noise	87

■ Manual Trolley

Body Components

Wheel	88
Suspension Shaft	88
Suspender	88

Lubrication

Gearing part of the wheel and drive gear	88
--	----

Travel Rail (Reccomendation)

Rail Surface	88
Deformation and Abrasion	89
Rail Mounting Bolt	89
Stopper	89

Function and Performance

Operational Check	89
Abnormal Noise	89

■ Parts Replacement based on Indication of the

CH Meter

Guidelines and Precautions on Gear Oil Change Cycle ...	90
Guidelines on Needle Bearing (for Idle Sheave)	
Grease Change Cycle.....	91

Guidelines on the service life of contactor and its replacement ...	91
Guidelines on Brake Inspection.....	91
Guidelines on Gear Parts Replacement	91
Guidelines on Motor Shaft Replacement.....	92
Guidelines on Bearing Replacement	92
Guidelines on Hook and Yoke Replacement	92
Guidelines on V ring Inspection	92

■ Check of Operating Hours and Number of Start

Single Speed Model	93
Dual Speed VFD Model	93

Safety Precautions

General Matters related to Inspection

⚠ DANGER



Prohibited

- Disassembly and assembly of the electric chain block must be performed by maintenance engineer.
- Do not use the part exceeding the service limit or criteria and the parts other than genuine part for KITO electric chain hoist.
Even if the part is genuine KITO part, it cannot be used for other model.
- Do not adjust or disassemble the Electromagnetic Brake, the Friction Clutch and the Friction Clutch with Mechanical Brake.
- When oiling the Friction Clutch and the Friction Clutch with Mechanical Brake, use KITO genuine oil (manufacturer specified oil).
- Do not carry out the inspection of electric chain hoist with a lifted load.
- Do not use the electric chain hoist removing the cushion rubber, the chain spring and the stopper.
- Turn off the main power when carrying out the inspection.
- When using oils such as gear oil and grease, avoid places with fire or sparks.

Failure to comply with these instructions may result in death or serious injury.



Mandatory

- Put the electric chain hoist on the floor or work bench when performing the repair and disassembling of the electric chain hoist.
- Even if each component of the electric chain hoist does not exceed the service limit, replace the part exceeding the total operating hours derived from the grade indicated on the electric chain hoist and the load factor.
- Do not use the electric chain hoist when any abnormality was observed during the inspection. Indicate "FAILURE" on the hoist and contact with maintenance engineer or KITO for repair.

Failure to comply with these instructions may result in death or serious injury.

⚠ CAUTION



Mandatory

- Indicate "CHECKING" when performing the inspection.
When a crane is operated erroneously during the inspection, it may result in the accident such as fall-off of parts and tools and downfall.
- Wear protection equipment such as protection goggles and gloves depending on the work contents.
Otherwise it may result in the injury due to scattered oil or sharp edge of a part.
- Pay attention to work method, work procedure and work posture.
If the product or the part is heavy, your hand is caught or your waist is hurt.
Especially be careful for the work on an unstable scaffold such as the work at high lifted place using stepladder.
- Wear helmet and safety belt when carrying the high lift work.
Otherwise it may result in injury or downfall accident.
- Remove the oil attached to the product or spilt on the floor.
Otherwise it may result in injury due to drop of the product or overturning.
- Keep the work area clean when disassembling the product.
Assembling or mixing the part other than genuine part may result in the damage of the product or the accident due to defective operation.

NOTE

- When performing the monthly inspection, carry out the daily inspection at the same time.
- When performing the annual inspection, carry out the monthly inspection at the same time.
- When detecting any abnormality during inspection due to erroneous use, instruct the operator and user for correct use of the electric chain hoist.
 - Ex. (1) The flaw on the Chain Guide A hit with the Chain (Cause: lifting incline)
 - (2) The deformation of the Cushion Rubber and the Chain Spring (Cause: excessive use of the limit switch)

■ Inspection sheets

When carrying out daily, monthly, and annual inspections, use the inspection sheets listed below, and store an inspection record.

Daily Inspection Check Sheet (P142)

Monthly Inspection Check Sheet (P144)

Annual Inspection Check Sheet (P146)

■ Inspection interval

The inspection interval must be adjusted to match the actual usage of the hoist.

Monthly and annual inspections will clarify the following information.

1. Wear and damage on parts
2. Operating hours and number of starts

The maintenance engineer or inspector should consider the above results and the future use plan for the hoist to determine whether to extend or shorten the interval until the next inspection before the service life of the part or hoist reaches its end.

First, perform the monthly and annual inspections to grasp the deterioration of parts and the operating status.

Monthly Inspection

General Matters on Monthly Inspection

DANGER



Mandatory

- During the monthly inspection, check the operation and confirm that it is working correctly. Neglecting to perform the functional check may result in death or serious injury.

General Matters on Handling the Dual Speed VFD Model

DANGER



Prohibited

- Do not change the VFD parameter.
When parameters need to be changed, ask our distributors nearest to the customer or KITO.
 - Do not carry out the work such as maintenance and inspection within 5 minutes after power off.
Wait for the completion of discharging of the capacitor inside the VFD.
 - Do not touch the controller cover as it becomes hot during operation.
 - Do not touch the controller cover until about 30 minutes elapsed after the stop of operation.
 - USE KITO genuine VFD.
The VFD requires the special specification for KITO. Be sure to use genuine VFD.
 - Do not change the connection of the VFD.
When the wires were removed for any reason, connect them again correctly checking the wiring diagram inside the controller cover.
 - Do not carry out withstand voltage test of a circuit while the VFD is connected.
 - Do not turn off the power while operating.
- Failure to comply with these instructions may result in death or serious injury and the damage of VFD.

NOTE

When performing the monthly inspection, carry out the daily inspection at the same time.

- Check the electric chain hoist as installed, standing on the floor.
- Refer to Appendix “Technical Material” (P124) for the structure of the product and the name of each part.

Electric Chain Hoist

Load Chain

- Check the Load Chain after removing the stain on the chain.
- Use the needle head caliper (point caliper) to measure the sum of pitches and wire diameter.
- Apply oil on the Load Chain after inspection.
- Application of lubricant influences on the life of the Load Chain considerably. Use the KITO genuine lubricant or equivalent (industrial lithium grease: consistency No.0)
- Release all loads from the Load Chain. Apply the lubricant to the linking portion of the Load Chain that engages the Load Sheave and the Idle Sheave and the linking portion of the Load Chain.
- After application of the lubricant lift/lower the electric chain hoist without load to spread the lubricant on the Load Chain.

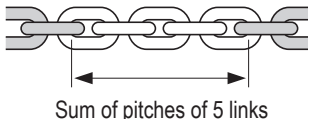
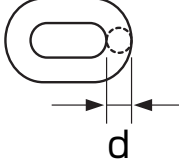
Item	Check method	Criteria	When failed
Elongation of Pitch	<ul style="list-style-type: none"> • Measure the elongation of pitch with point caliper. (Measure the sum of pitches of 5 links) 	<div style="border: 1px solid black; padding: 5px; margin-bottom: 10px;"> <p style="text-align: center;">NOTE</p> <p>Check the engaging point of the Load Sheave and the Idle Sheave especially carefully.</p> </div> <ul style="list-style-type: none"> • The limit value of the following “Sum of pitches of five links” must not be exceeded. 	Replace the Load Chain.
Abrasion of wire diameter	<ul style="list-style-type: none"> • Measure the wire diameter (d) with point caliper. 	<ul style="list-style-type: none"> • The limit value of the following “Wire diameter of the Load Chain” must not be exceeded. 	Replace the Load Chain.



Load Chain Pitch and Wire Diameter for Each Capacity

Code	Capacity	Load Chain diameter (mm)	Sum of 5 Links (mm)		Load Chain diameter (mm)
			Do not exceed the limit		Do not fall under the limit
			Standard	Limit	Limit
ER2-001H/IH	125kg	φ4.3×1	60.5	62.5	3.9
ER2-003S/IS/SD	250kg				
ER2-005L/IL/LD	500kg	φ6.0×1	84	86.5	5.4
ER2-005S/IS/SD					
ER2-010L/IL/LD	1t	φ7.7×1	108	111.2	6.9
ER2-010S/IS/SD					
ER2-015S/IS/SD	1.5t	φ10.2×1	143	147.2	9.2
ER2-020L/IL/LD	2t	φ10.2×1	143	147.2	9.2
ER2-020S/IS/SD					
ER2-025S/IS/SD	2.5t	φ11.2×1	157	161.7	10.1
ER2-030S/IS/SD	3t	φ10.2×2	143	147.2	9.2
ER2-050S/IS/SD	5t	φ11.2×2	157	161.7	10.1

(to be continued)

Monthly Inspection (continued)

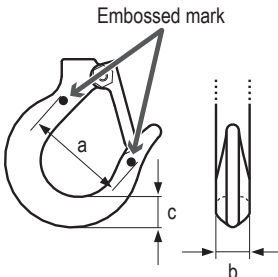
■ Top Hook, Bottom Hook

Item	Check method	Criteria	When failed																																																																				
<p>Opening and Abrasion of the Hook</p>	<ul style="list-style-type: none"> Check visually and measure with vernier caliper. 	<div style="background-color: black; color: white; padding: 5px; text-align: center;"> <p>⚠ CAUTION</p> </div> <p>! Mandatory</p> <ul style="list-style-type: none"> Compare the dimensions of a, b and c with those at purchasing. Check that they are within the criteria. <p>The use of the Hooks with these dimensions exceeding the criteria may result in bodily injury or property damage.</p> <table border="1" data-bbox="699 740 1172 893"> <thead> <tr> <th>Measured value (mm)</th> <th>Limit value</th> </tr> </thead> <tbody> <tr> <td>Dimension a</td> <td>Not to exceed the dimension at purchasing</td> </tr> <tr> <td>Dimension b</td> <td rowspan="2">Abrasion not to exceed 5%</td> </tr> <tr> <td>Dimension c</td> </tr> </tbody> </table> <ul style="list-style-type: none"> Following tables shows the nominal standard values. Please be aware that these values include tolerance because of forging. <table border="1" data-bbox="685 1087 1474 1570"> <thead> <tr> <th rowspan="2">Code</th> <th rowspan="2">Capacity</th> <th>Dimension a (mm)</th> <th colspan="2">Dimension b (mm)</th> <th colspan="2">Dimension c (mm)</th> </tr> <tr> <th>Standard</th> <th>Standard</th> <th>Limit value</th> <th>Standard</th> <th>Limit value</th> </tr> </thead> <tbody> <tr> <td>ER2-001H/IH/HD</td> <td>125kg</td> <td rowspan="3">45.0</td> <td rowspan="3">17.5</td> <td rowspan="3">16.6</td> <td rowspan="3">23.5</td> <td rowspan="3">22.3</td> </tr> <tr> <td>ER2-003S/IS/SD</td> <td>250kg</td> </tr> <tr> <td>ER2-005L/IL/LD</td> <td>500kg</td> </tr> <tr> <td>ER2-005S/IS/SD</td> <td rowspan="2">1t</td> <td rowspan="2">50.0</td> <td rowspan="2">22.5</td> <td rowspan="2">21.4</td> <td rowspan="2">31.0</td> <td rowspan="2">29.5</td> </tr> <tr> <td>ER2-010L/IL/LD</td> </tr> <tr> <td>ER2-010S/IS/SD</td> <td>1.5t</td> <td>60.0</td> <td>26.5</td> <td>25.2</td> <td>36.5</td> <td>34.7</td> </tr> <tr> <td>ER2-020L/IL/LD</td> <td rowspan="2">2t</td> <td rowspan="2">69.0</td> <td rowspan="2">31.5</td> <td rowspan="2">29.9</td> <td rowspan="2">43.5</td> <td rowspan="2">41.3</td> </tr> <tr> <td>ER2-020S/IS/SD</td> </tr> <tr> <td>ER2-025S/IS/SD</td> <td>2.5t</td> <td rowspan="2">73.0</td> <td rowspan="2">34.5</td> <td rowspan="2">32.8</td> <td rowspan="2">47.5</td> <td rowspan="2">45.1</td> </tr> <tr> <td>ER2-030S/IS/SD</td> </tr> <tr> <td>ER2-050S/IS/SD</td> <td>5t</td> <td>83.0</td> <td>42.5</td> <td>40.4</td> <td>56.0</td> <td>53.2</td> </tr> </tbody> </table>	Measured value (mm)	Limit value	Dimension a	Not to exceed the dimension at purchasing	Dimension b	Abrasion not to exceed 5%	Dimension c	Code	Capacity	Dimension a (mm)	Dimension b (mm)		Dimension c (mm)		Standard	Standard	Limit value	Standard	Limit value	ER2-001H/IH/HD	125kg	45.0	17.5	16.6	23.5	22.3	ER2-003S/IS/SD	250kg	ER2-005L/IL/LD	500kg	ER2-005S/IS/SD	1t	50.0	22.5	21.4	31.0	29.5	ER2-010L/IL/LD	ER2-010S/IS/SD	1.5t	60.0	26.5	25.2	36.5	34.7	ER2-020L/IL/LD	2t	69.0	31.5	29.9	43.5	41.3	ER2-020S/IS/SD	ER2-025S/IS/SD	2.5t	73.0	34.5	32.8	47.5	45.1	ER2-030S/IS/SD	ER2-050S/IS/SD	5t	83.0	42.5	40.4	56.0	53.2	<p>Replace the Hook.</p>
Measured value (mm)	Limit value																																																																						
Dimension a	Not to exceed the dimension at purchasing																																																																						
Dimension b	Abrasion not to exceed 5%																																																																						
Dimension c																																																																							
Code	Capacity	Dimension a (mm)	Dimension b (mm)		Dimension c (mm)																																																																		
		Standard	Standard	Limit value	Standard	Limit value																																																																	
ER2-001H/IH/HD	125kg	45.0	17.5	16.6	23.5	22.3																																																																	
ER2-003S/IS/SD	250kg																																																																						
ER2-005L/IL/LD	500kg																																																																						
ER2-005S/IS/SD	1t	50.0	22.5	21.4	31.0	29.5																																																																	
ER2-010L/IL/LD																																																																							
ER2-010S/IS/SD	1.5t	60.0	26.5	25.2	36.5	34.7																																																																	
ER2-020L/IL/LD	2t	69.0	31.5	29.9	43.5	41.3																																																																	
ER2-020S/IS/SD																																																																							
ER2-025S/IS/SD	2.5t	73.0	34.5	32.8	47.5	45.1																																																																	
ER2-030S/IS/SD																																																																							
ER2-050S/IS/SD	5t	83.0	42.5	40.4	56.0	53.2																																																																	
<p>Deformation, Flaw, Corrosion</p> 	<ul style="list-style-type: none"> Check visually. 	<ul style="list-style-type: none"> No deformation such as bend or twist No deep cut No loosened bolt or nut, or their fall off No considerable corrosion No attachment of foreign matter such as sputter 	<p>Replace the Hook.</p>																																																																				

■ Peripheral parts of the Body

Item	Check method	Criteria	When failed
Chain Container	<ul style="list-style-type: none"> • Check visually. 	<ul style="list-style-type: none"> • To be mounted to the body securely • No damage, tear, abrasion or deformation • Check no foreign matter inside the Chain Container. * Especially be careful when the electric chain hoist is used outdoor. • Make sure that the lift of the Load Chain is smaller than the capacity of the Chain Container. <div style="border: 1px solid black; padding: 5px; margin-top: 10px;"> <p style="text-align: center;">⚠ DANGER</p> <div style="display: flex; align-items: center;">  <ul style="list-style-type: none"> Do not use the torn Chain Container. Use the Chain Container with the capacity larger than the lift of the Load Chain. </div> <p style="margin-top: 5px;">Otherwise it may result in death or serious injury due to drop of the Load Chain.</p> </div>	<p>Replace the Chain Container. Discard the foreign matter in the Chain Container.</p> <p>Contact KITO or Distributor for the correct chain container.</p> <p>If the capacity of the Chain Container is smaller than the lift of the Load Chain, replace the Chain Container with the adequate Chain Container referring to “Mounting the Chain Container (P37)”.</p>

Monthly Inspection (continued)

■ Push Button Switch

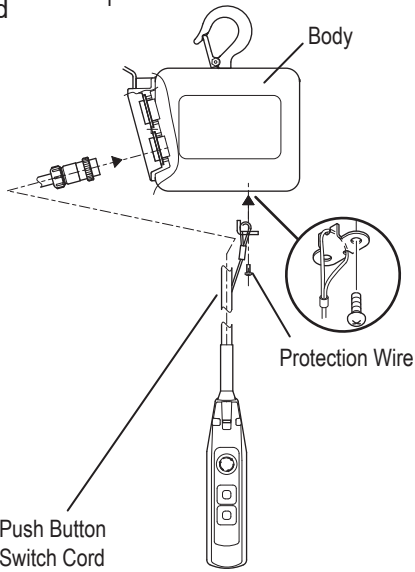
Item	Check method	Criteria	When failed
Push Button Switch Body	<ul style="list-style-type: none"> Check visually and by operation. 	<ul style="list-style-type: none"> No damage, deformation and loosened bolt. Push Button Switches can be operated smoothly. Emergency Stop Button can be operated and cancelled. 	Replace the Push Button Switch.
Push Button Switch Cord	<ul style="list-style-type: none"> Check visually. 	<ul style="list-style-type: none"> Push Button Switch Cord is securely connected. The Protection Wire is tied with the body so that Push Button Switch Cord is not strained directly even if the Push Button Switch is pulled. <hr/> <ul style="list-style-type: none"> To have no damage 	Tie the Push Button Switch Cord and the Protection Wire to the body properly. Replace the Push Button Switch Cord.

■ Power Supply

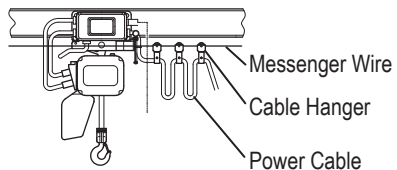
Item	Check method	Criteria	When failed
Power Cable	<ul style="list-style-type: none"> Check visually. 	<ul style="list-style-type: none"> Power Cable to have enough length. To have no damage To be connected securely 	Replace the Power Cable.
Cable Hanger	<ul style="list-style-type: none"> Check visually and by moving by hand. 	<ul style="list-style-type: none"> To have no damage To move smoothly To be mounted at equal interval ... Appropriate interval 1.5 m 	Re-mount the Cable Hangers for no hindrance to cable motion.
Messenger Wire	<ul style="list-style-type: none"> Check visually. 	<ul style="list-style-type: none"> To have no sag 	Remove the sag.

■ Function and Performance

- Check the following item with no load.

Item	Check method	Criteria	When failed
Abnormal Noise	<ul style="list-style-type: none"> Check the noise of gear, motor and the Load Chain during operation with no load. <div style="border: 1px solid black; padding: 5px; margin-top: 10px;"> <p style="text-align: center;">NOTE</p> <p>Sound is also an important check point. Always be careful for the noise of the electric chain hoist.</p> </div>	<ul style="list-style-type: none"> To sound no irregular rotating noise. To sound no howling of motor and scraping sound of the Brake To sound no abnormal noise 	Replace the abnormal part.
		<ul style="list-style-type: none"> To sound no popping sound from the Load Chain 	Check the Load Chain. (Refer to P69.)

(to be continued)

Monthly Inspection (continued)**Motorized Trolley****Travel Rail (Recommendation)**

Item	Check method	Criteria	When failed
Appearance	<ul style="list-style-type: none"> Check visually. 	<ul style="list-style-type: none"> To have no apparent deformation and damage 	Check items in accordance with “Travel Rail” described in Chapter 2 “Annual Inspection”. (P86)

Push Button Switch, Power Supply

Carry out the inspection referring to “Monthly Inspection Items” of the electric chain hoist (ER2). (P72, 73)

Connection Status

Item	Check method	Criteria	When failed
connection parts	<ul style="list-style-type: none"> Swing the chain to rock the trolley 	<ul style="list-style-type: none"> The electric chain block does not tilt significantly. No looseness at the joints and no rattling between parts. 	Make connections firmly.

Manual Trolley**Travel Rail (Recommendation)**

Item	Check method	Criteria	When failed
Appearance	<ul style="list-style-type: none"> Check visually. 	<ul style="list-style-type: none"> To have no apparent deformation and damage 	Check items in accordance with “Travel Rail” described in Chapter 2 “Annual Inspection”. (P88)

Connection Status

Item	Check method	Criteria	When failed
connection parts	<ul style="list-style-type: none"> Swing the chain to rock the trolley 	<ul style="list-style-type: none"> The electric chain block lightly rocks. No looseness at the joints and no rattling between parts. 	Make connections firmly.

Annual Inspection

■ General Matters on Annual Inspection

DANGER



Mandatory

- Put the electric chain hoist on the floor or work bench when repairing or disassembling the electric chain hoist.
- During the annual inspection, check the operation and confirm that it is working correctly.
 - Wear insulating gloves when measuring voltage.
 - When measuring the electric characteristics (insulation resistance, but except voltage measurement), turn off the power.

Failure to comply above instructions may result in death or serious injury.

■ General Matters on Handling the Dual Speed VFD Model

DANGER



Prohibited

- Do not change the VFD parameters.
When parameters need to be changed, ask our distributors nearest to the customer or KITO.
- Do not carry out the work such as maintenance and inspection within 5 minutes after power off.
Wait for the completion of discharging of the capacitor inside the VFD.
- Do not touch the controller cover as it becomes hot during operation.
- Do not touch the controller cover until about 30 minutes elapsed after the stop of operation.
- USE KITO genuine VFD.
The VFD requires the special specification for KITO. Be sure to use genuine VFD.
- Do not change the connection of the VFD.
When the wires were removed for any reason, connect them again correctly checking the wiring diagram inside the controller cover.
- Do not carry out withstand voltage test of a circuit while the VFD is connected.
- Do not turn off the power while operating.

Failure to comply with these instructions may result in death or serious injury and the damage of VFD.

NOTE

When performing the annual inspection, carry out the monthly inspection at the same time.

- Refer to Appendix "Technical Material" (P124) for the structure of the product and the name of each part.

Annual Inspection (continued)

Electric Chain Hoist

Check of the Operation History

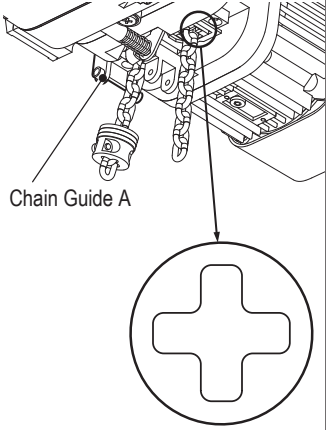

Item	Check method	Criteria	When failed
Operating Hours and Number of Starts	<ul style="list-style-type: none"> Check the operating hours and number of starts with the CH Meter or VFD. 	<ul style="list-style-type: none"> Perform maintenance by referring to “Parts Replacement based on Indication of CH Meter”. (P90) <p>Caution)</p> <p>Based on the operation history confirmed here, consider the future operation schedule and the deterioration of each part, and then decide whether to check the operation history again at the next monthly inspection and carry out appropriate maintenance or perform immediate maintenance.</p>	

Peripheral parts of the Body

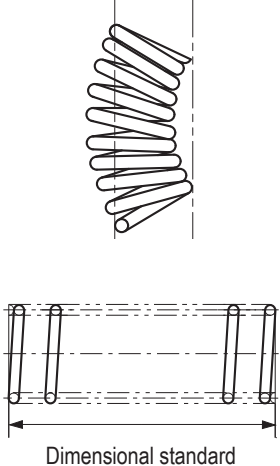
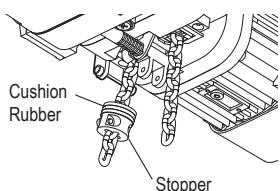
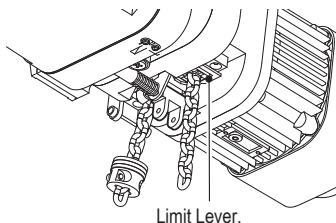
Item	Check method	Criteria	When failed
Chain Guide A	<ul style="list-style-type: none"> Check visually.  <p>Chain Guide A</p>	<ul style="list-style-type: none"> To have no apparent abrasion, deformation and damage To have no flaw due to hitting by the Load <div style="border: 1px solid black; padding: 5px;"> <p>⚠ CAUTION</p> <p>! Mandatory</p> <ul style="list-style-type: none"> The flaw due to hitting is caused by wrong use such as lifting a load in an inclined direction. If the abrasion is observed on the Chain Guide, the Load Chain may be worn also. Refer to the item of Load Chain Abrasion and check the abrasion. <p>Neglecting the check of the Load Chain abrasion may result in bodily injury or property damage.</p> </div>	Replace the Chain Guide A.

Item	Check method	Criteria	When failed																																																
<p>Chain Spring</p>	<ul style="list-style-type: none"> Check visually and measure the dimensions. 	<ul style="list-style-type: none"> Check visually to have no apparent setting (deformation). <div style="border: 1px solid black; padding: 5px; margin-bottom: 10px;"> <p style="text-align: center;">⚠ CAUTION</p> <p style="text-align: center;">!</p> <p>Mandatory</p> <ul style="list-style-type: none"> The deformation of the Cushion Rubber and the Chain Spring is caused by excessive use of the Friction Clutch and the Limit Switch. Operate the electric chain hoist properly. <p>Otherwise it may result in bodily injury or property damage.</p> </div> <p>Service Limit of Chain Spring for Capacity (Do not fall short of the limit value.)</p> <table border="1" data-bbox="662 840 1144 1315"> <thead> <tr> <th rowspan="2">Code</th> <th rowspan="2">Capacity</th> <th colspan="2">Length of Chain Spring</th> </tr> <tr> <th>Standard</th> <th>Limit value</th> </tr> </thead> <tbody> <tr> <td>ER2-015S</td> <td rowspan="2">1.5t</td> <td>–</td> <td>–</td> </tr> <tr> <td>ER2-015IS/SD</td> <td></td> <td></td> </tr> <tr> <td>ER2-020L</td> <td rowspan="3">2t</td> <td>70</td> <td>67</td> </tr> <tr> <td>ER2-020IL/LD</td> <td></td> <td></td> </tr> <tr> <td>ER2-020S</td> <td>85</td> <td>81</td> </tr> <tr> <td>ER2-020IS/SD</td> <td></td> <td></td> <td></td> </tr> <tr> <td>ER2-025S</td> <td rowspan="2">2.5t</td> <td>75</td> <td>72</td> </tr> <tr> <td>ER2-025IS/SD</td> <td></td> <td></td> </tr> <tr> <td>ER2-030S</td> <td rowspan="2">3t</td> <td>85</td> <td>81</td> </tr> <tr> <td>ER2-030IS/SD</td> <td></td> <td></td> </tr> <tr> <td>ER2-050S</td> <td rowspan="2">5t</td> <td>75</td> <td>72</td> </tr> <tr> <td>ER2-050IS/SD</td> <td></td> <td></td> </tr> </tbody> </table>	Code	Capacity	Length of Chain Spring		Standard	Limit value	ER2-015S	1.5t	–	–	ER2-015IS/SD			ER2-020L	2t	70	67	ER2-020IL/LD			ER2-020S	85	81	ER2-020IS/SD				ER2-025S	2.5t	75	72	ER2-025IS/SD			ER2-030S	3t	85	81	ER2-030IS/SD			ER2-050S	5t	75	72	ER2-050IS/SD			<p>Replace the Chain Spring.</p>
Code	Capacity	Length of Chain Spring																																																	
		Standard	Limit value																																																
ER2-015S	1.5t	–	–																																																
ER2-015IS/SD																																																			
ER2-020L	2t	70	67																																																
ER2-020IL/LD																																																			
ER2-020S		85	81																																																
ER2-020IS/SD																																																			
ER2-025S	2.5t	75	72																																																
ER2-025IS/SD																																																			
ER2-030S	3t	85	81																																																
ER2-030IS/SD																																																			
ER2-050S	5t	75	72																																																
ER2-050IS/SD																																																			
<p>Stopper</p>	<ul style="list-style-type: none"> Check visually. 	<ul style="list-style-type: none"> The stopper must be attached securely at the third link from the no load end of the Load Chain. 	<p>Attach the Stopper at the third link.</p>																																																
<p>Limit Lever</p>	<ul style="list-style-type: none"> Check visually and by moving by hand. 	<ul style="list-style-type: none"> To have no deformation, damage and abrasion To move smoothly To have no stain 	<p>Replace the Limit Lever. Disassemble the Limit Lever and clean.</p>																																																

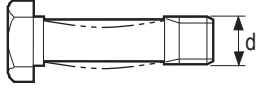
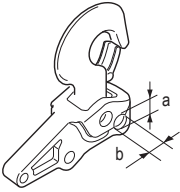
Annual Inspection (continued)

Item	Check method	Criteria	When failed											
Chain Pin (double type only)	<ul style="list-style-type: none"> Check visually and measure with vernier caliper.  <p>Chain Pin</p>	<ul style="list-style-type: none"> To have no apparent deformation and flaw. <p>Service Limit of Chain Pin (Do not fall short of the limit value.)</p> <table border="1"> <thead> <tr> <th rowspan="2">Code</th> <th colspan="2">Diameter d (mm)</th> </tr> <tr> <th>Standard</th> <th>Limit value</th> </tr> </thead> <tbody> <tr> <td>030S/IS/SD</td> <td>10.8</td> <td>10.3</td> </tr> <tr> <td>050S/IS/SD</td> <td>12.9</td> <td>12.3</td> </tr> </tbody> </table>	Code	Diameter d (mm)		Standard	Limit value	030S/IS/SD	10.8	10.3	050S/IS/SD	12.9	12.3	Replace the Chain Pin.
Code	Diameter d (mm)													
	Standard	Limit value												
030S/IS/SD	10.8	10.3												
050S/IS/SD	12.9	12.3												
Connection Yoke D (double type only)	<ul style="list-style-type: none"> Measure the dimensions a and b with vernier caliper. 	<ul style="list-style-type: none"> The difference between dimensions a (vertical) and b (lateral) must be within 0.5 mm. To have no apparent deformation and abrasion 	Replace the Connection Yoke D.											
Shaft Retainer Clip	<ul style="list-style-type: none"> Check visually.  <p>Shaft Retainer Clip</p>	<ul style="list-style-type: none"> To have no deformation, abrasion and damage To be attached securely without loosening 	Replace the Shaft Retainer Clip.											

■ Gear box (Gear case, Body)

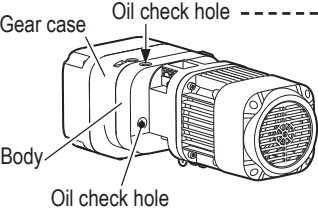
Item	Check method	Criteria	When failed
Appearance	<ul style="list-style-type: none"> Check visually. 	<ul style="list-style-type: none"> To have no harmful deformation, crack, and remarkable corrosion. To have no crack at the connecting part between the body and the hook or suspender. 	Replace the damaged part.
Oil Leakage	<ul style="list-style-type: none"> Check visually. 	<p>To have no leakage of oil from the following parts.</p> <ul style="list-style-type: none"> Joint between body and gear case. Oil plugs and oil check hole. 	Replace the packing G or the plug packing.
Oil amount and stain	<ul style="list-style-type: none"> Check the oil level from the oil check hole. (The position of the oil check hole depends on the model. See P40.) 	<ul style="list-style-type: none"> Oil is filled enough close to the oil check hole. Check the oil level through the oil cap at the top (shown by an arrow) for electric chain hoist equipped with the friction clutch with mechanical brake. (Do not open the oil check hole at the side. Or, oil leaks out.) When checking the oil level, insert the check bar into the oil check hole, tilting the bar slightly, to see the oil level. The distance between the hole and the oil level is 75 mm for the body B, 100 mm for the body C/D, 120 mm for the body E, and 130 mm for the body F respectively. Gear oil has viscosity but not stained. 	Replace the Oil.

■ Electromagnetic Brake

Item	Check method	Criteria	When failed																																																						
Appearance	<ul style="list-style-type: none"> Remove the Brake Cover and check visually. 	<ul style="list-style-type: none"> To have no loosened bolt and screw. 	Tighten bolts and screws.																																																						
		<ul style="list-style-type: none"> To have no flaw and damage. 	Replace the Electromagnetic Brake.																																																						
Gap	<ul style="list-style-type: none"> Measure the gap with thickness gauge. 	<ul style="list-style-type: none"> Electromagnetic Brake Gap Limit (not to exceed the limit) 	Replace the Electromagnetic Brake.																																																						
		<table border="1"> <thead> <tr> <th colspan="2">Single speed model</th> <th colspan="2">Dual speed VFD model</th> <th colspan="2">Pole change model</th> </tr> <tr> <th>Code</th> <th>Gap limit (mm)</th> <th>Code</th> <th>Gap limit (mm)</th> <th>Code</th> <th>Gap limit (mm)</th> </tr> </thead> <tbody> <tr> <td>ER2-001H</td> <td rowspan="5">0.75</td> <td>ER2-001IH</td> <td rowspan="3">0.60</td> <td>ER2-001HD</td> <td rowspan="5">0.60</td> </tr> <tr> <td>ER2-003S</td> <td>ER2-003IS</td> <td>ER2-003SD</td> </tr> <tr> <td>ER2-005L</td> <td>ER2-005IL</td> <td>ER2-005LD</td> </tr> <tr> <td>ER2-005S</td> <td>ER2-005IS</td> <td>ER2-005SD</td> </tr> <tr> <td>ER2-010L</td> <td>ER2-010IL</td> <td>ER2-010LD</td> </tr> <tr> <td>ER2-010S</td> <td rowspan="4">0.40</td> <td>ER2-010IS</td> <td rowspan="4">0.40</td> <td>ER2-010SD</td> <td rowspan="4">0.90</td> </tr> <tr> <td>ER2-015S</td> <td>ER2-015IS</td> <td>ER2-015SD</td> </tr> <tr> <td>ER2-020L</td> <td>ER2-020IL</td> <td>ER2-020LD</td> </tr> <tr> <td>ER2-020S</td> <td>ER2-020IS</td> <td>ER2-020SD</td> </tr> <tr> <td>ER2-030S</td> <td rowspan="3">1.10</td> <td>ER2-030IS</td> <td rowspan="3">0.50</td> <td>ER2-030SD</td> <td rowspan="3">0.90</td> </tr> <tr> <td>ER2-025S</td> <td>ER2-025IS</td> <td>ER2-025SD</td> </tr> <tr> <td>ER2-050S</td> <td>ER2-050IS</td> <td>ER2-050SD</td> </tr> </tbody> </table>		Single speed model		Dual speed VFD model		Pole change model		Code	Gap limit (mm)	Code	Gap limit (mm)	Code	Gap limit (mm)	ER2-001H	0.75	ER2-001IH	0.60	ER2-001HD	0.60	ER2-003S	ER2-003IS	ER2-003SD	ER2-005L	ER2-005IL	ER2-005LD	ER2-005S	ER2-005IS	ER2-005SD	ER2-010L	ER2-010IL	ER2-010LD	ER2-010S	0.40	ER2-010IS	0.40	ER2-010SD	0.90	ER2-015S	ER2-015IS	ER2-015SD	ER2-020L	ER2-020IL	ER2-020LD	ER2-020S	ER2-020IS	ER2-020SD	ER2-030S	1.10	ER2-030IS	0.50	ER2-030SD	0.90	ER2-025S	ER2-025IS	ER2-025SD
Single speed model		Dual speed VFD model		Pole change model																																																					
Code	Gap limit (mm)	Code	Gap limit (mm)	Code	Gap limit (mm)																																																				
ER2-001H	0.75	ER2-001IH	0.60	ER2-001HD	0.60																																																				
ER2-003S		ER2-003IS		ER2-003SD																																																					
ER2-005L		ER2-005IL		ER2-005LD																																																					
ER2-005S		ER2-005IS	ER2-005SD																																																						
ER2-010L		ER2-010IL	ER2-010LD																																																						
ER2-010S	0.40	ER2-010IS	0.40	ER2-010SD	0.90																																																				
ER2-015S		ER2-015IS		ER2-015SD																																																					
ER2-020L		ER2-020IL		ER2-020LD																																																					
ER2-020S		ER2-020IS		ER2-020SD																																																					
ER2-030S	1.10	ER2-030IS	0.50	ER2-030SD	0.90																																																				
ER2-025S		ER2-025IS		ER2-025SD																																																					
ER2-050S		ER2-050IS		ER2-050SD																																																					
		<div style="border: 1px solid black; padding: 5px;"> <p style="text-align: center;">⚠ DANGER</p> <p> Do not adjust or disassemble the Electromagnetic Brake.</p> <p>Adjusting or disassembling the Electromagnetic Brake may result in death or serious injury.</p> </div>																																																							
Hub Joint	<ul style="list-style-type: none"> Check visually. 	<ul style="list-style-type: none"> To have no apparent deformation and abrasion Hub spring must be seated. 	Replace the Hub and the Electromagnetic Brake.																																																						
V ring	<ul style="list-style-type: none"> Check visually. 	<ul style="list-style-type: none"> To have no deformation and crack 	Replace the V ring.																																																						

(to be continued)

Annual Inspection (continued)

■ Electrical Equipment

Item	Check method	Criteria	When failed
Electrical Parts	<ul style="list-style-type: none"> Remove the Controller Cover and check the electrical parts visually. 	<ul style="list-style-type: none"> To have no damaged or burnt part. To have no loosened bolt. Electrical parts must be mounted securely. 	Replace the damaged or burnt electrical part. Mount the electrical part securely. Replace the electrical part with service life.
Wiring		<ul style="list-style-type: none"> Wiring must be fixed to the Electrical Parts securely. Connectors must be inserted securely. To have no wire breakage and burning 	Connect wirings securely. Replace the wiring with new wiring, referring to Chapter 3 “Guidance on Troubleshooting”. (P96)
Contamination and attachment of foreign matter		<ul style="list-style-type: none"> To have no waterdrop or foreign matter. 	Remove the foreign matter.
VFD	<ul style="list-style-type: none"> Check the parts with service life (see VFD Manual.) 	<ul style="list-style-type: none"> Electrolytic capacitor: 3000 hours (depending on the use) 	<ul style="list-style-type: none"> Replace the VFD.

■ Electric Characteristics Measurement

Item	Check method	Criteria	When failed
Source Voltage	<ul style="list-style-type: none"> Measure the voltage with a circuit tester. 	<ul style="list-style-type: none"> The source voltage of the rated voltage $\pm 10\%$ at the receiving terminal must be supplied when operating with the capacity. <div style="border: 1px solid black; padding: 5px; margin-top: 10px;"> <p style="text-align: center;">⚠ DANGER</p> <div style="display: flex; align-items: center;"> <ul style="list-style-type: none"> Be careful of electric shock when measuring the voltage. </div> <p>Electric shock may result in death or serious injury.</p> </div>	Supply proper voltage.
Insulation Resistance (For crane use)	<ul style="list-style-type: none"> Measure the insulation resistance with megger. (Resistance between energized and non-energized parts ... Each phase of R(L1), S(L2) and T(L3) and the earth wire) 	<ul style="list-style-type: none"> Insulation resistance must be 5 MΩ or higher. <div style="border: 1px solid black; padding: 5px; margin-top: 10px;"> <p style="text-align: center;">⚠ DANGER</p> <div style="display: flex; align-items: center;"> <ul style="list-style-type: none"> Turn off the power when measuring the insulation resistance. </div> <p>Measuring the insulation resistance without turning off the power may result in death or serious injury.</p> </div>	Replace the Body.

Item	Check method	Criteria	When failed
Grounding Resistance (For crane use)	<ul style="list-style-type: none"> Measure the grounding resistance with earth-resistance meter. 	<ul style="list-style-type: none"> grounding resistance 100Ω or less <div style="border: 1px solid black; padding: 5px;"> <p style="text-align: center;">⚠ DANGER</p> <div style="display: flex; align-items: center;">  <p> <ul style="list-style-type: none"> Turn off the power when measuring the grounding resistance. </p> </div> <p>Mandatory Measuring the grounding resistance without turning off the power may result in death or serious injury due to electric shock.</p> </div>	Make a grounding correctly.

■ Function and Performance

After reassembly, hoist should be operated with no load, checking up/down function, limit switch and brake, before applying rated load.

When load bearing members (except chain) or brakes have been replaced, load the electric chain hoist with the rated load and check that:

Item	Check method	Criteria	When failed
Operational Check	<ul style="list-style-type: none"> Operate with the rated load. 	<ul style="list-style-type: none"> Refer to the criteria for the same item in the daily inspection section. (See P32) 	Take measures by referring to Chapter 3 "Guidance on Troubleshooting". (P96)
Brake	<ul style="list-style-type: none"> Operate with the rated load. 	<ul style="list-style-type: none"> When stopping the operation, the Brake must be applied immediately and the motor must stop. <p>Up/Down: Stop distance must be 1 % or less of the traveling distance for one minute.</p>	Take measures by referring to Chapter 3 "Guidance on Troubleshooting". (P96)

(to be continued)

Annual Inspection (continued)

Motorized Trolley



Brake

Item	Check method	Criteria	When failed
Appearance	<ul style="list-style-type: none"> Disassemble the Brake and check it visually. 	<ul style="list-style-type: none"> To have no deformation, flaw and damage on the Brake Drum and the Motor Cover. 	Replace the Part.
		<ul style="list-style-type: none"> To have no deformation and damage on the Brake Spring. 	Replace the Brake Spring.
Abrasion of Brake Pad	<ul style="list-style-type: none"> Disassemble the Brake and measure the abrasion. 	Trolley Brake Service Limit (Do not fall under the limit.)	Replace the Motor Cover.

Speed	Dimension	Standard	Limit
Single Speed	B	32.5	31.0
Dual Speed (VFD)			
Dual Speed (500V Class)	B'	36.8	36.3

Body Components

Item	Check method	Criteria	When failed																																								
Wheel	<ul style="list-style-type: none"> Check visually. Measure dimensions D and d with vernier caliper. <p>Wheel for I · H beam (0.5 to 5 t)</p> <p>Measure the outer diameter with vernier caliper.</p>	<ul style="list-style-type: none"> To have no apparent deformation and damage Abrasion Limit of Wheel (Do not fall under the limit.) <table border="1" style="margin-left: auto; margin-right: auto;"> <thead> <tr> <th rowspan="2">Capacity (t)</th> <th rowspan="2">Beam type</th> <th colspan="2">D (mm)</th> <th colspan="2">d (mm)</th> </tr> <tr> <th>Standard</th> <th>Limit</th> <th>Standard</th> <th>Limit</th> </tr> </thead> <tbody> <tr> <td>125, 250, 500kg</td> <td>I · H</td> <td>95</td> <td>91</td> <td>91.5</td> <td>87.5</td> </tr> <tr> <td>1</td> <td>I · H</td> <td>95</td> <td>91</td> <td>91.5</td> <td>87.5</td> </tr> <tr> <td>1.5, 2</td> <td>I · H</td> <td>110</td> <td>105</td> <td>106</td> <td>101</td> </tr> <tr> <td>2.5, 3</td> <td>I · H</td> <td>125</td> <td>118</td> <td>121</td> <td>114</td> </tr> <tr> <td>5</td> <td>I · H</td> <td>140</td> <td>132</td> <td>135</td> <td>127</td> </tr> </tbody> </table>	Capacity (t)	Beam type	D (mm)		d (mm)		Standard	Limit	Standard	Limit	125, 250, 500kg	I · H	95	91	91.5	87.5	1	I · H	95	91	91.5	87.5	1.5, 2	I · H	110	105	106	101	2.5, 3	I · H	125	118	121	114	5	I · H	140	132	135	127	Replace the Wheel.
Capacity (t)	Beam type	D (mm)			d (mm)																																						
		Standard	Limit	Standard	Limit																																						
125, 250, 500kg	I · H	95	91	91.5	87.5																																						
1	I · H	95	91	91.5	87.5																																						
1.5, 2	I · H	110	105	106	101																																						
2.5, 3	I · H	125	118	121	114																																						
5	I · H	140	132	135	127																																						
Side Roller	<ul style="list-style-type: none"> Check visually. Measure outer diameter of the worn part with vernier caliper. 	<ul style="list-style-type: none"> To have no apparent deformation and damage Abrasion Limit of Side Roller (Do not fall under the limit.) <table border="1" style="margin-left: auto; margin-right: auto;"> <thead> <tr> <th rowspan="2">Capacity (t)</th> <th colspan="2">Outer diameter (mm)</th> </tr> <tr> <th>Standard</th> <th>Limit</th> </tr> </thead> <tbody> <tr> <td>125, 250, 500kg</td> <td>38</td> <td>37</td> </tr> <tr> <td>1</td> <td>38</td> <td>37</td> </tr> <tr> <td>1.5, 2</td> <td>43</td> <td>42</td> </tr> <tr> <td>2.5, 3</td> <td>43</td> <td>42</td> </tr> <tr> <td>5</td> <td>55</td> <td>54</td> </tr> </tbody> </table>	Capacity (t)	Outer diameter (mm)		Standard	Limit	125, 250, 500kg	38	37	1	38	37	1.5, 2	43	42	2.5, 3	43	42	5	55	54	Replace the Side Roller.																				
Capacity (t)	Outer diameter (mm)																																										
	Standard	Limit																																									
125, 250, 500kg	38	37																																									
1	38	37																																									
1.5, 2	43	42																																									
2.5, 3	43	42																																									
5	55	54																																									

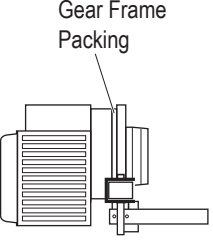
Item	Check method	Criteria	When failed
Suspension Shaft	<ul style="list-style-type: none"> Check visually. 	<ul style="list-style-type: none"> To have no apparent deformation and abrasion 	Replace the Suspension Shaft.
Suspender	<ul style="list-style-type: none"> Check visually. 	<ul style="list-style-type: none"> The Suspender must be combined securely with the top pin and the Yoke bolt. 	Replace the Suspender.
Gear Frame Packing	<ul style="list-style-type: none"> Check visually. 	<ul style="list-style-type: none"> To have no tear, breakage, and grease leakage. 	Replace the Gear Frame Packing.

■ Lubrication

Item	Check method	Criteria	When failed
Gearing part of the wheel and drive gear	<ul style="list-style-type: none"> Check visually 	<ul style="list-style-type: none"> Appropriate amount of grease is adhered. 	Apply an appropriate amount of grease to the gears. Shell Gadus S2 V100 #3 or Shell Alvania grease 3 or grease equivalent to NLGI#3 grade

(to be continued)

Annual Inspection (continued)

■ Travel Rail (Recommendation)

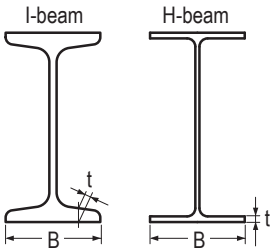
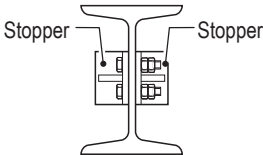
Item	Check method	Criteria	When failed
Rail Surface	<ul style="list-style-type: none"> Check visually. 	<ul style="list-style-type: none"> To have no attachment of paint, oil and foreign matter. To have no dust and powder due to abrasion 	Clean the Travel Rail.
Deformation and Abrasion	<ul style="list-style-type: none"> Check the deformation and abrasion visually and measure them with vernier caliper. 	<ul style="list-style-type: none"> To have no deformation of beam flange such as twist and shear drop To have no exceeding abrasion of rail surface Service limit of B: up to 95 % of the dimension at purchasing Service limit of t: up to 90 % of the dimension at purchasing 	Replace or repair the Travel Rail.
Rail Mounting Bolt	<ul style="list-style-type: none"> Check visually. 	<ul style="list-style-type: none"> To have no loosened bolt or fall-off 	Tighten the bolts securely.
Stopper	<ul style="list-style-type: none"> Check visually. 	<ul style="list-style-type: none"> The stoppers must be mounted at the both ends of the Travel Rail securely. 	Tighten the Stoppers.

■ Relay Cable

Item	Check method	Criteria	When failed
Appearance	<ul style="list-style-type: none"> Check the cable surface visually. 	<ul style="list-style-type: none"> The Relay Cable has no deformation or damage. To be mounted securely. 	Replace the Relay Cable.

■ Electrical Equipment and Electric Characteristics

Refer to Electric Chain Hoist (ER2) Annual Inspection (P80).

■ Function and Performance

After reassembly, trolley should be operated with no load, checking transverse motion and brake, before applying rated load.

When load bearing members or brakes have been replaced, load the trolley with the rated load and check that:



Item	Check method	Criteria	When failed
Operational Check	<ul style="list-style-type: none"> Operate with the rated load. 	<ul style="list-style-type: none"> Refer to the criteria for the same item in the daily inspection section. (See P34) 	Take measures by referring to Chapter 3 "Guidance on Troubleshooting". (P96)
Brake	<ul style="list-style-type: none"> Operate with the rated load. 	<ul style="list-style-type: none"> When stopping the operation, the Brake must be applied immediately and the motor must stop. <p>Traveling : Stop distance must be 10 % or less of the traveling distance for one minute. (Without swinging of the load. Except the case when the load is swinging.)</p>	Take measures by referring to Chapter 3 "Guidance on Troubleshooting". (P96)
Abnormal Noise	<ul style="list-style-type: none"> Operate with the rated load. 	<ul style="list-style-type: none"> To have no irregular rotating noise. To sound no howling of motor and scraping sound of the Brake. 	Take measures by referring to Chapter 3 "Guidance on Troubleshooting". (P96)

(to be continued)

Annual Inspection (continued)

Manual Trolley

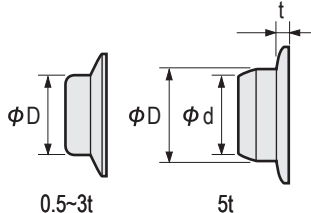
Body Components

Item	Check method	Criteria	When failed																																																																					
Wheel	<ul style="list-style-type: none"> Check visually. Measure dimensions D and t with vernier caliper.  <ul style="list-style-type: none"> Measure the outer diameter with vernier caliper. 	<ul style="list-style-type: none"> To have no apparent deformation and damage The abrasion of the wheel should not be less than the limit value To have no deformation of contact surface To have no streaks on flange <table border="1" data-bbox="698 638 1380 1042"> <thead> <tr> <th colspan="2">Capacity</th> <th rowspan="2">Beam</th> <th colspan="2">D (mm)</th> <th colspan="2">d (mm)</th> <th colspan="2">Flange thickness t (mm)</th> </tr> <tr> <th>TSP</th> <th>TSG</th> <th>Standard</th> <th>Limit</th> <th>Standard</th> <th>Limit</th> <th>Standard</th> <th>Limit</th> </tr> </thead> <tbody> <tr> <td>125kg</td> <td>250kg</td> <td rowspan="2">-</td> <td rowspan="2">60</td> <td>58.5</td> <td rowspan="10" style="text-align: center;">/</td> <td rowspan="10" style="text-align: center;">/</td> <td rowspan="10" style="text-align: center;">/</td> <td rowspan="10" style="text-align: center;">/</td> </tr> <tr> <td>500kg</td> <td></td> <td></td> <td>To have no considerable damage or crack on the contact surface.</td> </tr> <tr> <td rowspan="2">1t</td> <td>125kg</td> <td>H-steel</td> <td rowspan="2">71</td> <td>69.5</td> <td>To have no considerable damage or crack on the contact surface.</td> </tr> <tr> <td>250kg</td> <td>I-steel</td> <td></td> <td>To have no considerable damage or crack on the contact surface.</td> </tr> <tr> <td rowspan="2">1.5t, 2t</td> <td>500kg</td> <td>H-steel</td> <td rowspan="2">85</td> <td>83.5</td> <td>To have no considerable damage or crack on the contact surface.</td> </tr> <tr> <td>1t</td> <td>I-steel</td> <td></td> <td>To have no considerable damage or crack on the contact surface.</td> </tr> <tr> <td rowspan="2">2.5t, 3t</td> <td></td> <td>H-steel</td> <td rowspan="2">100</td> <td>98.5</td> <td>To have no considerable damage or crack on the contact surface.</td> </tr> <tr> <td></td> <td>I-steel</td> <td></td> <td>To have no considerable damage or crack on the contact surface.</td> </tr> <tr> <td>5t</td> <td></td> <td>H-steel</td> <td>118</td> <td>112</td> <td>113</td> <td>107</td> <td>9.6</td> <td>6.7</td> </tr> </tbody> </table>	Capacity		Beam	D (mm)		d (mm)		Flange thickness t (mm)		TSP	TSG	Standard	Limit	Standard	Limit	Standard	Limit	125kg	250kg	-	60	58.5	/	/	/	/	500kg			To have no considerable damage or crack on the contact surface.	1t	125kg	H-steel	71	69.5	To have no considerable damage or crack on the contact surface.	250kg	I-steel		To have no considerable damage or crack on the contact surface.	1.5t, 2t	500kg	H-steel	85	83.5	To have no considerable damage or crack on the contact surface.	1t	I-steel		To have no considerable damage or crack on the contact surface.	2.5t, 3t		H-steel	100	98.5	To have no considerable damage or crack on the contact surface.		I-steel		To have no considerable damage or crack on the contact surface.	5t		H-steel	118	112	113	107	9.6	6.7	Replace the Wheel.
Capacity		Beam	D (mm)			d (mm)		Flange thickness t (mm)																																																																
TSP	TSG		Standard	Limit	Standard	Limit	Standard	Limit																																																																
125kg	250kg	-	60	58.5	/	/	/	/																																																																
500kg									To have no considerable damage or crack on the contact surface.																																																															
1t	125kg	H-steel	71	69.5					To have no considerable damage or crack on the contact surface.																																																															
	250kg	I-steel							To have no considerable damage or crack on the contact surface.																																																															
1.5t, 2t	500kg	H-steel	85	83.5					To have no considerable damage or crack on the contact surface.																																																															
	1t	I-steel							To have no considerable damage or crack on the contact surface.																																																															
2.5t, 3t		H-steel	100	98.5					To have no considerable damage or crack on the contact surface.																																																															
		I-steel							To have no considerable damage or crack on the contact surface.																																																															
5t		H-steel	118	112					113	107	9.6	6.7																																																												
Suspension Shaft	<ul style="list-style-type: none"> Check visually. 	<ul style="list-style-type: none"> To have no apparent deformation and abrasion 	Replace the Suspension Shaft.																																																																					
Suspender	<ul style="list-style-type: none"> Check visually. 	<ul style="list-style-type: none"> The Suspender must be combined securely with the top pin and the Yoke bolt. 	Replace the Suspender.																																																																					

Lubrication

Item	Check method	Criteria	When failed
Gearing part of the wheel and drive gear	<ul style="list-style-type: none"> Check visually 	<ul style="list-style-type: none"> Appropriate amount of grease is adhered. 	Apply an appropriate amount of grease to the gears. ENEOS Corp.Cup grease 1-2 or grease equivalent to NLGI#2 grade

Travel Rail (Recommendation)

Item	Check method	Criteria	When failed
Rail Surface	<ul style="list-style-type: none"> Check visually. 	<ul style="list-style-type: none"> To have no attachment of paint, oil and foreign matter. To have no dust and powder due to abrasion 	Clean the Travel Rail.

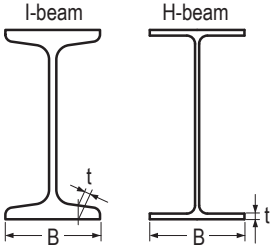
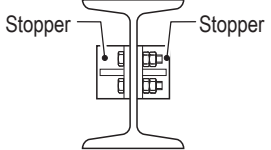
Item	Check method	Criteria	When failed
Deformation and Abrasion	<ul style="list-style-type: none"> Check the deformation and abrasion visually and measure them with vernier caliper. 	<ul style="list-style-type: none"> To have no deformation of beam flange such as twist and shear drop To have no exceeding abrasion of rail surface Service limit of B: up to 95 % of the dimension at purchasing Service limit of c: up to 90 % of the dimension at purchasing 	Replace or repair the Travel Rail.
Rail Mounting Bolt	<ul style="list-style-type: none"> Check visually. 	<ul style="list-style-type: none"> To have no loosened bolt or fall-off 	Tighten the bolts securely.
Stopper	<ul style="list-style-type: none"> Check visually. 	<ul style="list-style-type: none"> The stoppers must be mounted at the both ends of the Travel Rail securely. 	Tighten the Stoppers.

■ Function and Performance

After reassembly, trolley should be operated with no load, checking transverse motion, before applying rated load. When load bearing members have been replaced, load the trolley with the rated load and check that:

Item	Check method	Criteria	When failed
Operational Check	<ul style="list-style-type: none"> Operate with the rated load. 	<ul style="list-style-type: none"> Refer to the criteria for the same item in the daily inspection section. (See P35) 	Take measures by referring to Chapter 3 "Guidance on Troubleshooting". (P96)
Abnormal Noise	<ul style="list-style-type: none"> Operate with the rated load. 	<ul style="list-style-type: none"> To have no irregular rotating noise. 	Take measures by referring to Chapter 3 "Guidance on Troubleshooting". (P96)

Parts Replacement based on Indication of the CH Meter

Check the number of starts and operating hours by referring to “Check of Operating Hours and Number of Start”. (P93)
For the dual speed VFD model, please also read the “VFD Manual” (separate volume) to use it correctly.

Guidelines and Precautions on Gear Oil Change Cycle

Change the gear oil in accordance with the rate of loading and the operating hours.

- Change the oil at every five years even if the operating hours do not reach at the following hours.

Rate of loading		Operating hour for gear oil change		
		Every 120 hrs	Every 240 hrs	Every 360 hrs
Light	A case where the capacity is rarely applied. Usually the hoist is used with a light load.			○
Medium	A case where the capacity is applied considerably frequently. Usually the hoist is used with a medium load.		○	
Heavy	A case where the capacity is applied considerably frequently. Usually the hoist is used with a heavy load.	○		
Ultra heavy	A case where the capacity is applied constantly.	○		

DANGER



Mandatory

- Gear oil differs depending on the specification. Use of wrong gear oil may result in the drop of the lifted load. Be sure to use the designated gear oil.

Failure to comply with this instruction may result in death or serious injury.

Type of gear oil and its amount for one body

Specification	Code	Gear oil amount (ml)	Oil manufacturer	Oil type
Friction Clutch	ER2-001H, 001IH, 001HD, 003S, 003IS, 003SD	520	KITO genuine oil	KITO genuine oil
	ER2-005L, 005IL, 005S, 005IS,	540		
	ER2-005LD, 005SD	470		
	ER2-010L, 010IL, 010SD, 010LD	620		
	ER2-010S, 010IS	680		
	ER2-015S, 015IS, 015SD, 020L, 020IL, 020LD	1300		
	ER2-020S, 020IS, 030S, 030IS	1900		
	ER2-020SD, 030SD	1800		
	ER2-025S, 025IS, 025SD, 050S, 050IS, 050SD	1900		
Friction Clutch with Mechanical Brake	ER2-001H, 001IH, 003S, 003IS, 003SD	680	KITO genuine oil	KITO genuine oil
	ER2-005L, 005IL, 005LD, 005SD	820		
	ER2-005S, 005IS	900		
	ER2-010L, 010IL, 010LD, 010SD	1050		
	ER2-010S, 010IS	1100		
	ER2-015S, 015IS, 015SD, 020L, 020IL, 020LD	2000		
	ER2-020S, 020IS, 030S, 030IS	2500		
	ER2-020SD, 030SD	2300		
	ER2-025S, 025IS, 025SD, 050S, 050IS, 050SD	2700		

* Oil is available in 0.7L and 1.0L bottles only.

■ Guidelines on Needle Bearing (for Idle Sheave) Grease Change Cycle

Rate of loading		Operating hour for gear oil change	
		Every 200 hrs	Every 400 hrs
Light	A case where the capacity is rarely applied. Usually the hoist is used with a light load.		○
Medium	A case where the capacity is applied considerably frequently. Usually the hoist is used with a medium load.		○
Heavy	A case where the capacity is applied considerably frequently. Usually the hoist is used with a heavy load.	○	
Ultra heavy	A case where the capacity is applied constantly.	○	

Note) Apply an appropriate amount of Shell Sunlight Grease 3 for lubrication.

■ Guidelines on the service life of contactor and its replacement

Replace the Contactor in accordance with the following rate of inching and the number of start. Replace the Contactor every five years even if the number of start does not reach at the following.

Rate of inching		Number of start to replace contactor		
		Every 200,000 times	Every 500,000 times	Every 1 million times
Low	Normally operating with scarce inching			○
Medium	Normally operating with occasional inching		○	
High	Normally operating with inching at a half times or more	○		

NOTE

Be sure to use the designated contactor.

■ Guidelines on Brake Inspection

When the number of start reaches at one million times, inspect the brake gap and carry out the following treatment depending on the condition of the brake gap.

When the number of start reaches at two million times, replace the brake unit as a whole irrespective of the condition of the brake gap.

Condition of brake gap	Treatment
Brake gap reaches at the limit gap.	Replace the brake as a whole.
Brake gap reaches at 50 to 100 % of the limit gap.	Check the Brake at every 100,000 times until the brake gap reaches at the limit gap.
Brake gap is less than 50 % of the limit gap.	Check the Brake at every 200,000 times.

■ Guidelines on Gear Parts Replacement (Load Gear, Gear B, Pinion, Friction Clutch, Friction Clutch with Mechanical Brake)

Body grade		Operating hours to replace parts		
		Every 800 hours	Every 1600 hours	Every 3200 hours
M6, 3m		–	–	Parts replacement
M5, 2m		–	Parts replacement	–
M4, 1Am		Parts replacement	–	–

(to be continued)

Parts Replacement based on Indication of the CH Meter (continued)

Guidelines on Motor Shaft (with Rotor) Replacement

Operating hours to replace parts		Every 400 hours	Every 800 hours	Every 1600 hours	Every 3200 hours
Body grade					
	M6, 3m	–	Apply grease on spline*	–	Parts replacement
	M5, 2m	–	Apply grease on spline	Parts replacement	–
	M4, 1Am	Apply grease on spline	Parts replacement	–	–

* Grease needs to be applied on spline part every 800, 1600 and 2400 hours.

Guidelines on Bearing Replacement

Operating hours to replace parts		Every 800 hours	Every 1600 hours	Every 3200 hours
Body grade				
	M6, 3m	–	–	Parts replacement
	M5, 2m	–	Parts replacement	–
	M4, 1Am	Parts replacement	–	–

Guidelines on Hook and Yoke Replacement

Replace the Hook and Yoke in accordance with the rate of loading and the number of start in the following table.

Number of start to replace parts		Every million times	Every 1.5 million times	Every 2 million times
Rate of loading				
Light	A case where the capacity is rarely applied. Usually the hoist is used with a light load.			○
Medium	A case where the capacity is applied considerably frequently. Usually the hoist is used with a medium load.		○	
Heavy	A case where the capacity is applied considerably frequently. Usually the hoist is used with a heavy load.	○		
Ultra heavy	A case where the capacity is applied constantly.	○		

Guidelines on V ring Inspection

Apply grease every 200 hours of operation. (Grease: Sumico Lubricant Co., Ltd. Molytherm No. 2 or general grease for oil seal.) Refer to "Product Structure and Names of Each Part" (P124) for the location of the V ring.

Check of Operating Hours and Number of Start (CH Meter)

■ Single Speed Model

■ CH Meter: Start Times/Operating Hour Display Device

Contactor ON/OFF (lowering) times and operating hours(motor energizing hours for lowering × 2) are displayed.

Use these values for control of operating condition and maintenance at inspection and annual inspection.

<How to use the CH Meter>

Open the controller cover and press the button at the side of the terminal panel.

The display ①, ② and ③ appears in the LCD window in the sequence and then disappears automatically.

- ① Operating hours (1,089 hours in the right example)
- ③ + ② Number of start (2,031,091 times in the right example)

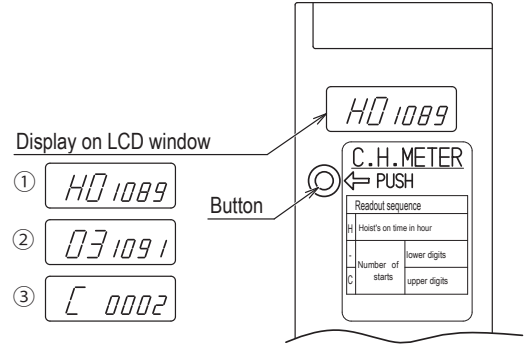

⚠ CAUTION

Prohibited

- Do not disassemble or replace the battery.

Failure to comply with this instruction causes bodily injury or loss of property.

■ Dual Speed VFD Model

■ Check with the VFD (CH Meter Function)

NOTE

This section is an excerpt from the VFD Manual. The maintenance administrator should perform the operation. For details about the operation method and other items, refer to the VFD Manual (separate volume).

The number of starts is split into the higher order and lower order when displayed on the LED panel. Calculate the number of starts based on the displayed information.

■ Display Content of the Number of Starts and Operating Hours

The number of starts is split into the higher order and lower order when displayed, as shown in the following table.

















No.	Name	Description
U7-01	Number of starts (higher order)	1000 times of starts of lowering are displayed as 1. Up to 10,000 are displayed. The maximum indicates 10,000 × 1,000 = 10 million times.
U7-02	Number of starts (lower order)	One time of start of lowering is displayed as 1. Up to 999 are displayed. When it reaches 1000 after 999, the value of U7-01(higher order) is incremented by 1. At the same time, the value of U7-02 (lower order) is reset to 0.
U7-03	Operating hours	One hour of operating hours is displayed as 1. Up to 65535 hours are displayed.

Note: The maximum value that can be displayed does not indicate the service life.

■ How to Display the Number of Starts and Operating Hours

The following shows the procedure for the operating hours. To display the number of starts, take the following procedure similarly.

- Example: Displaying U7-03 (operating hours).

Procedure	LED panel
1. Turn on the power supply.	 Initial screen
2. Press  until the monitor display screen is displayed.	
3. Press  to display the parameter setting screen, and then press  .	 Parameter setting screen
4. Press  or  to display U7-01.	
5. Press  and  or  to set it to U7-03 (driving time).	
6. When you press  , the current value is displayed.	 75 hours
7. Monitoring finishes. To restart operation, press  until the display returns to the initial screen.	 2 seconds

■ Calculating the number of starts

Calculate the number of starts based on the displayed information in the higher order and lower order.

Example: When "81" is displayed in U7-01, and "567" is displayed in U7-02

$$\text{Number of starts of lowering} = 81 \times 1,000 + 567 = 81,567 \text{ times}$$

■ Operating Hours

When "122" is displayed in U7-03, the operating hours is 122 hours.

Chapter 3

Troubleshooting

This chapter describes the main failure cause and inspection items based on the fault conditions. The repair work (and maintenance work as well) of the electric chain hoist is accompanied with disassembling/assembling work. Refer to the separate "Disassembling/Assembling Manual" for the correct work.

■ Guidance on Troubleshooting.....	96
■ Safety Precautions	100
■ Troubleshooting.....	101

Guidance on Troubleshooting

Following table is the summary of the main failure causes based on the failure conditions and their inspection items. Refer to the page of each item for the check method, treatment and the details of countermeasure.

- Refer to “Technical Materials” (P124) for the product structure and the component name of each part.

■ Single speed model

Conditions		Main fault contents	Check item	Reference page	
Electric chain hoist does not operate without load	No brake sound	No Electromagnetic contactor operating sound	Improper source voltage	Power	101
			Breakage or burning of control circuit Faulty electrical part	Circuit breaker	101
				Power Cable	102
				Internal wiring	106
				Electromagnetic Contactor	107
				Transformer	106
				Fuse	107
				Upper/Lower Limit Switch	108
	Push Button Switch	109			
	Contactor Electromagnetic operating sound	Breakage or burning of power circuit, Faulty motor or brake	Motor	103	
Brake			104		
Internal wiring			106		
Electromagnetic Contactor (melted contact points)			107		
Brake operating sound	Breakage of driving part Sticking of Bearing	Load Gear, Gear B, Pinion, Motor Shaft	118		
		Bearing	119		
Electric chain hoist operates without load	Does not operate with a load (Motor sound howling)	Open phase (single phase operation)	Power	101	
			Power Cable	102	
			Motor	103	
			Electromagnetic Contactor (melted contact points)	107	
	Operates slowly with a load	Overload (clutch activated)	Friction Clutch	111	
Friction Clutch with Mechanical Brake			112		
Operates differently from the indication of the Push Button Switch.	Operates differently from the indication of the Push Button Switch (operates in the opposite direction)	Negative phase connection	Power Cable	102	
		Wrong connection	Internal wiring	106	
			Push Button Switch	109	
	Does not operate when operating any one of the Push Button Switch	Breakage of control circuit	Internal wiring	106	
			Push Button Switch	109	
		Faulty electrical part	Electromagnetic Contactor	107	
			Upper/Lower Limit Switch	108	
Does not stop normally.	Does not stop even if the Push Button Switch is released.	Melted contact point	Electromagnetic Contactor	107	
	Too long (or short) stopping distance	Abrasion of brake lining	Brake	104	
	Does not stop at the upper/lower limit.	Negative phase connection	Power Cable	102	
		Wrong connection	Internal wiring	106	
			Push Button Switch	109	

Conditions		Main fault contents	Check item	Reference page	
Abnormal noise	Popping sound	Abrasion of the Load Chain	Load Chain	115	
		Abrasion of the Load Sheave	Load Sheave, Idle Sheave	117	
	Strange operating sound	Abrasion or breakage of Gear	Load Gear, Gear B, Pinion, Motor Shaft	118	
		Deterioration of Bearing	Bearing	119	
	Brake noise	Sound when applied (scraping noise)	Dragging	Brake	104
		Sound when released	Abrasion of brake lining	Brake	104
	Friction Clutch with Mechanical Brake (sound when lowering)	Scraping noise	Use of improper oil other than the designated oil	Friction Clutch with Mechanical Brake	112
	Sound at curved rail (friction noise)		Mechanical interference of the rail and the wheel	Traveling motion of the Trolley	119
	Abnormal noise from the trolley motor		Gears, motor shaft wear or damage	Traveling motion of the Trolley	119
			Deterioration of Bearing	Bearing	119
Unable to travel	Motorized Trolley/Manual Trolley		Slipping wheel	Traveling motion of the Trolley	119
			Inclined rail		
			Pulling a load in an inclined direction (floating wheel)		
			Defective gear engagement		
			Locking of brake		
	Motorized Trolley	Electric system failure (refer to the item of electric chain hoist)	Traveling motion of the Trolley	120	
Manual Trolley	Defective engagement of the Hand Wheel and the Hand Chain				
Serpentine motion Abnormal noise Unable to travel smoothly	Motorized Trolley/Manual Trolley		Mechanical interference of the rail and the wheel	Traveling motion of the Trolley	119
			Wrong adjustment of collar		
			Uneven abrasion of the wheel		
			Deformation of the wheel		
			Deterioration of Bearing		
			Deformation and abrasion of the rail		
			Abrasion of the Brake Pad		
			Poor mating between gears		
Hook and those related to Hook		Deformation	Hook	113	
Load Chain and those related to Load Chain		Abrasion, elongation, twist	Load Chain	115	
Electric shock when touching the body and Push Button Switch		Improper grounding, breakage of earth wire	Electric shock	111	

(to be continued)

Guidance on Troubleshooting (continued)

■ Dual Speed VFD Model

Conditions		Main fault contents	Check item	Reference page
Unable to restart the VFD by resetting with emergency stop (the case when the VFD cannot be reset even after cool down)		Those related to VFD	Check the error code of VFD referring to “VFD Manual”.	“VFD Manual” (annex)
Electric chain hoist does not operate without load	No brake operating sound	Improper source voltage	Power	101
		Breakage and burning of control circuit	Circuit breaker	101
			Power Cable	102
		Faulty electrical part	Internal wiring	106
			Transformer	106
			Fuse	107
		Relay	107	
		Interface Board	110	
		VFD	110	
		Upper/Lower Limit Switch	108	
		Push Button Switch	109	
		Breakage and burning of power circuit	Motor	103
			Brake	104
			Internal wiring	106
Relay (melted contact point)	107			
VFD trip due to motor overheat (electronic thermal relay)	VFD	110		
	VFD overheat	VFD	110	
Brake operating sound	Breakage of driving part Sticking of Bearing	Load Gear, Gear B, Pinion, Motor Shaft	118	
		Bearing	119	
Electric chain hoist operates without load	Does not operate with a load (Motor sound howling)	Overload (Clutch activated)	Friction Clutch	111
			Friction Clutch with Mechanical Brake	112
	Operates slowly with a load	Voltage drop	Power Cable	102
	Electric chain hoist operates in low speed mode, but does not operate in high speed mode or operates slowly.	Low source voltage	Power	101
		Voltage drop	Power Cable	102
Does not operate in lowering or in low speed mode.	Faulty Braking Resistor	Braking Resistor	110	
Operates differently from the indication of the Push Button Switch.	Operates differently from the indication of the Push Button Switch (operates in the opposite direction)	Negative phase connection of motor lead wires	Motor	103
		Wrong connection	Internal wiring	106
			Push Button Switch	109
	Does not operate when operating any one of the Push Button Switch	Breakage of control circuit	Internal wiring	106
			Push Button Switch	109
		Faulty electrical part	VFD	110
			Interface Board	110
	Upper/Lower Limit Switch	108		

Conditions		Main fault contents	Check item	Reference page	
Does not stop normally.	Too long stopping distance	Relay failure or melted contact point	Relay	107	
	Too long (or short) stopping distance	Abrasion of brake lining	Brake	104	
	Does not stop at the upper/lower limit.	Negative phase connection of motor lead wires	Power Cable	102	
		Wrong connection	Internal wiring Push Button Switch	106 109	
Abnormal noise	Popping sound	Abrasion of the Load Chain	Load Chain	115	
		Abrasion of the Load Sheave	Load Sheave, Idle Sheave	117	
	Strange operating sound	Abrasion or breakage of Gear Deterioration of Bearing	Load Gear, Gear B, Pinion, Motor Shaft	118	
			Bearing	119	
	Brake noise	Sound when applied (scraping noise)	Dragging	Brake	104
		Sound when released	Abrasion of brake lining	Brake	104
	Friction Clutch with Mechanical Brake (sounds when lowering)	Scraping noise	Use of improper oil other than the designated oil	Friction Clutch with Mechanical Brake	112
	Sound at curved rail (friction noise)	Mechanical interference of the rail and the wheel	Traveling motion of the Trolley	119	
Abnormal noise from the trolley motor		Gears, motor shaft wear or damage	Traveling motion of the Trolley	119	
		Deterioration of Bearing	Bearing	119	
Unable to travel	Motorized Trolley/Manual Trolley	Slipping wheel	Traveling motion of the Trolley	119	
		Inclined rail			
		Pulling a load in an inclined direction (floating wheel)			
		Defective gear engagement			
		Locking of brake			
	Motorized Trolley	Electric system failure (refer to the item of electric chain hoist)	Traveling motion of the Trolley	120	
Manual Trolley	Defective engagement of the Hand Wheel and the Hand Chain				
Serpentine motion Abnormal noisenable to travel smoothly	Motorized Trolley/Manual Trolley	Mechanical interference of the rail and the wheel	Traveling motion of the Trolley	119	
		Wrong adjustment of collar			
		Uneven abrasion of the wheel			
		Deformation of the wheel			
		Deterioration of Bearing			
		Deformation and abrasion of the rail			
		Abrasion of the Brake Pad			
		Poor mating between gears			
Hook and those related to Hook	Deformation	Hook	113		
Load Chain and those related to Load Chain	Abrasion, elongation, twist	Load Chain	115		
Electric shock when touching the body and Push Button Switch	Improper grounding, breakage of earth wire	Electric shock	111		

Safety Precautions

General Matters on Failure Cause and Countermeasure

⚠ DANGER



Prohibited

- **Do not disassemble or repair the electric chain hoist by the personnel other than maintenance engineer.**
“Disassembling/Assembling Manual” and “Parts List” are provided separately for the maintenance. Disassembling and repair must be performed by the maintenance engineer in accordance with these materials for maintenance.
- **When replacing the part, be sure to use the genuine part for KITO electric chain hoist ER2, ER2M, ER2SP and ER2SG.**
Even if the part is the KITO genuine part, the part for different model may not be used. Use the correct part in accordance with separate “Disassembling/Assembling Manual”.

Failure to comply with this content may result in death or serious injury.



Mandatory

- **When any abnormality is observed during the maintenance (repair) of the electric chain hoist, survey the cause by the maintenance engineer and carry out the repair.**
- **Be sure to keep the following when repairing the electric chain hoist:**
 - **Be sure to turn off the power.**
 - **Be sure to indicate “INSPECTION”.**
 - **Carry out the repair without lifting a load.**
- **Be sure to pay attention to the change of the operating sound of electric chain hoist and trolley.**
The change of operating sound is an important factor to judge the failure.

Failure to comply with this content may result in death or serious injury.

General Matters on Handling the Dual Speed VFD Model

⚠ DANGER





Prohibited

- **Do not change the VFD parameters.**
When parameters need to be changed, ask our distributors nearest to the customer or KITO.
- **Do not carry out the work such as maintenance and inspection within 5 minutes after power off.**
Wait for the completion of discharging of the capacitor inside the VFD.
- **Do not touch the controller cover as it becomes hot during operation.**
- **Do not touch the controller cover until about 30 minutes elapsed after the stop of operation.**
- **USE KITO genuine VFD.**
The VFD requires the special specification for KITO. Be sure to use genuine VFD.
- **Do not change the connection of the VFD.**
When the wires were removed for any reason, connect them again correctly checking the wiring diagram inside the controller cover.
- **Do not carry out withstand voltage test of a circuit while the VFD is connected.**
- **Do not turn off the power while operating.**

Failure to comply with these instructions may result in death or serious injury and the damage of VFD.

Troubleshooting

Power

Symptom	Cause	Remedy	Main factor	Countermeasure
Electric chain hoist does not operate.	Improper source voltage	Measure the voltage of each phase at power receiving terminal. If the source voltage is improper, check the power receiving facility.	Faulty power receiving facility	Check the power receiving facility regularly.
<div style="background-color: black; color: white; padding: 5px; display: inline-block;">  DANGER </div> <ul style="list-style-type: none"> Be careful about electric shock when checking the power. <p>Careless power check may result in death or serious injury due to electric shock.</p>				
<div style="display: flex; align-items: center;">  <p>Mandatory</p> </div>				

Circuit breaker (Distribution panel)

Symptom	Cause	Remedy	Main factor	Countermeasure
Electric chain hoist does not operate.	Breaker was tripped due to short circuit.	Replace or repair the short-circuited part.	Cable breakage, burning of electrical parts	Refer to each item of Power Cable, Motor, Brake, Internal Wiring, Transformer and Electromagnetic Contactor.
	Breaker was tripped due to insufficient breaker capacity.	Check the breaker capacity. Replace it if the capacity is insufficient.	Wrong selection of breaker capacity	Use the breaker with proper capacity. (See P52.)
	Breaker was tripped due to over current.	Check the cause of over current and take the necessary countermeasure. (Refer to each item of Power Cable, Motor, Brake, Internal Wiring, Transformer and Contactor.)	Over voltage, low voltage, over load	Refer to each item of Power Cable, Motor, Brake, Internal Wiring, Transformer and Electromagnetic Contactor.

Troubleshooting (continued)

Power Cable

Symptom	Cause	Remedy	Main factor	Countermeasure
Electric chain hoist does not operate.	Wire breakage (more than two wires)	Check the conduction, flaw, crimping of terminals and soldering of plug. When any deficiency was observed, repair or replace the cable.	Excessive force applied on the cable	Support the cable with Cable Support Arm securely.
			Non use of shake proof cable	Use shake proof cable to the moving part.
			Twist of wire	Layout the wires without twisting.
			Cable was impeded by other facility.	Fix the cable not to be impeded by other facility.
	Wire burning (more than two wires)	Check the cable. Replace it if burnt.	Temperature rise due to insufficient cable capacity	Use the cable with proper capacity. (See P52.)
			Cables are bundled.	Do not bundle wires.
Insufficient insertion of plug	Insert the connector plug to the end of the receptacle. Tighten the coupling ring securely.	Insufficient insertion at the installation	Fix the connector plug to the receptacle securely.	
		Loosening of the fixing thread due to impact or vibration	Use the electric chain hoist avoiding the large impact.	
Slow start or unable to start	Insufficient cable capacity	Check the cable size for adequacy. Replace with the proper cable if the cable capacity is insufficient.	Voltage drop due to insufficient cable capacity	Use the cable with proper capacity. (See P52.)
Electric chain hoist operates but unable to lift a load. (single phase status)	Breakage or burning of one phase only	Refer to the breakage and burning of above items.		
Electric chain hoist operates in the direction different to the push button operation (negative phase).	Wrong connection of power line when wiring	Change two wires of power line.	Wrong connection when assembling	Refer to the connection diagram and connect wires correctly.

Motor

Symptom	Cause	Remedy	Main factor	Countermeasure
Motor does not operate.	Motor coil burning (two or more phases)	Measure the coil resistance of each phase. Replace the motor when the resistance of all phases are infinity.	Over current due to over voltage or low voltage	Operate the electric chain hoist at the rated voltage.
			Over current due to over load	Use the electric chain hoist with a load less than the capacity.
			Operation exceeding short time rating or intermittent rating	Check the short time rating and intermittent rating. Use the electric chain hoist within these ratings.
			Excessive inching or plugging operation (consecutive impression of start rush current)	Do not perform excessive operation.
			Over current due to brake dragging	Refer to the items of Brake.
	Lead wire breakage (more than two lead wires)	Measure the coil resistance of each phase. Replace the motor when the resistance of all phases are infinity.	Lead wire damaged at assembling	Assemble with care.
Electric chain hoist operates but unable to lift a load. (single phase status)	Motor coil burning (only one phase)	Measure the coil resistance of each phase. Replace the motor when the resistance of all phases are infinity.	Layer short due to poor insulation of coil (between phases)	Be careful about the intrusion of foreign matter into the motor when assembling.
	Lead wire breakage (only in one lead wire)	Measure the coil resistance of each phase. Replace the motor when the resistance of all phases are infinity.	Lead wire damaged at assembling	Be careful not to have the lead wire caught when assembling.
			Vibration, impact	Use the electric chain hoist avoiding the impact.

Troubleshooting (continued)

Brake

⚠ DANGER



Prohibited

- Do not adjust/disassemble the Electromagnetic Brake.

Adjusting or disassembling the Electromagnetic Brake may result in death or serious injury.

Symptom	Cause	Remedy	Main factor	Countermeasure
Electromagnetic Brake does not operate.	Brake coil burning	Measure the coil resistance of the Brake coil. Replace the Electromagnetic Brake when the resistance is infinity.	Over current due to over voltage or low voltage	Operate the electric chain hoist at the rated voltage.
			Excessive inching or plugging operation (consecutive impression of start rush current)	Do not perform excessive operation.
			Over current due to over load	Use the electric chain hoist with a load less than the capacity.
			Operation exceeding short time rating or intermittent rating	Check the short time rating and intermittent rating. Use the electric chain hoist within these ratings.
			Over current due to open phase operation	The electric chain hoist cannot lift a load in open phase operation. When any abnormality is observed, stop the operation immediately and check the cause of open phase operation.
	Abrasion of Brake Lining (exceeding the magnetic attraction of the electromagnetic brake)	Measure the brake gap. If the gap exceeds the service limit, replace the electromagnetic brake unit as a whole (See P79.)	Excessive inching operation	Do not perform excessive operation.
	Breakage of Electromagnetic Brake lead wire	Check the conduction of the lead wire. Replace the wire without conduction.	Lead wire damaged at assembling	Be careful not to have the lead wire caught when assembling.
	Insufficient connection of brake lead wire at insertion terminal	Connect the insertion terminal securely. Replace the loose insertion terminal if any.	Insufficient connection at assembling	Connect the insertion terminal securely at assembling.

Symptom	Cause	Remedy	Main factor	Countermeasure	
Electromagnetic Brake does not operate.	Rusting	When the Brake is rusted shut, replace the brake unit as a whole.	Wrong assembling of packings	Assemble the brake cover packings and V ring securely. Replace the packing if deteriorated.	
			Leaving the electric chain hoist in an environment with rich moisture	Operate the electric chain hoist regularly.	
			Dew condensation	Pay attention to the use in an environment where the ambient temperature changes rapidly.	
	Breakage of rectifier	Measure the resistance of the rectifier with circuit tester. Anode terminal : Negative probe of the circuit tester Cathode terminal : Positive probe of the circuit tester (measure the resistance in kΩ range) When the resistance is almost zero, the rectifier is normal. In other cases, replace the rectifier.	Over current due to over voltage or low voltage	Operate the electric chain hoist at the rated voltage.	
			Excessive inching or plugging operation (consecutive impression of start rush current)	Do not perform excessive operation.	
			Over current due to over load	Use the electric chain hoist with a load less than the capacity.	
			Operation exceeding short time rating or intermittent rating	Check the short time rating and intermittent rating. Use the electric chain hoist within these ratings.	
			Over current due to open phase operation	The electric chain hoist cannot lift a load in open phase operation. When any abnormality is observed, stop the operation immediately and check the cause of open phase operation.	
	Too long (or short) stopping distance (stopping distance may change slightly depending on the temperature.)	Abrasion of brake lining	Measure the brake gap. If the gap exceeds the service limit, replace the electromagnetic brake unit as a whole (See P79.)	Excessive inching operation	Do not perform excessive operation.
	Louder operating sounds	Abrasion of brake lining	Measure the brake gap. If the gap exceeds the service limit, replace the electromagnetic brake unit as a whole (See P79.)	Excessive inching operation	Do not perform excessive operation.

(to be continued)

Troubleshooting (continued)

Internal wiring

Symptom	Cause	Remedy	Main factor	Countermeasure
Electric chain hoist does not operate.	Breakage of wire	Check the wire. Repair the wire if broken.	Vibration, impact	Use the electric chain hoist avoiding the impact.
			Lead wire damaged at assembling	Be careful not to have the lead wire caught when assembling.
		Check the terminal. Repair the terminal without conduction.	Improper crimping	Use the proper crimping tool.
	Wrong wiring	Check the wiring in accordance with the wiring diagram. Correct the wiring if it is wrong.	Wrong wiring at assembling	Correct the wiring in accordance with the wiring diagram.
	Loosened terminal screw (results in heat generation to burn)	Tighten the loosened screws.	Insufficient tightening at assembling	Tighten screws securely.
Vibration, impact			Use the electric chain hoist avoiding the impact.	
Incomplete connection of plug, connector and insertion terminal	Connect plug, connector and insertion terminal correctly if they are not connected securely. Tighten the lock ring of the connector plug securely.	Incomplete connection at assembling	Connect plug, connector and insertion terminal securely.	

Transformer

Symptom	Cause	Remedy	Main factor	Countermeasure
Electric chain hoist does not operate. (Electromagnetic Contactor does not operate.)	Burnout or breakage of transformer coil	Measure the resistance of transformer coil. If it is infinity, replace the transformer.	Over voltage	Operate the electric chain hoist with the rated voltage.
			Excessive inching or plugging operation (consecutive impression of start rush current)	Do not perform excessive operation.
			Over current due to defective operation of Electromagnetic contactor	Refer to the items of Electromagnetic Contactor.
			Vibration, impact	Use the electric chain hoist avoiding the impact.
	Breakage of lead wire	Check the lead wires of the transformer. Repair or replace the transformer if the lead wire has no conduction.	Vibration, impact	Use the electric chain hoist avoiding the impact.

Electromagnetic Contactor, Relay

Symptom	Cause	Remedy	Main factor	Countermeasure
Electric chain hoist does not stop	Electromagnetic Contact point welding, or fusing	Operate the contactor manually to check the conduction. When the contact point is welded or fused, replace the contactor. When the device is a miniature relay, check the contact point visually.	Excessive inching or plugging operation (consecutive impression of start rush current)	Do not perform excessive operation.
			Over voltage	Operate the electric chain hoist with the rated voltage.
			Over current due to over load	Use the electric chain hoist with a load less than the capacity.
Electric chain hoist does not operate.	Burnout or breakage of relay coil or contactor coil	Measure the resistance of relay coil or contactor coil. If it is infinity, replace the relay or the contactor.	Excessive inching or plugging operation (consecutive impression of start rush current)	Do not perform excessive operation.
			Over voltage	Operate the electric chain hoist with the rated voltage.
			Chattering due to low voltage (consecutive impression of start rush current)	Operate the electric chain hoist with the rated voltage.
	Damaged moving parts	Operate the Electromagnetic contactor by its manual operation part. Replace the contactor if it does not move smoothly. Check the miniature relay visually if it does not have damaged part.	Vibration, impact	Use the electric chain hoist avoiding the impact.

Fuse

Symptom	Cause	Remedy	Main factor	Countermeasure
Electric chain hoist does not operate. (Electromagnetic Contactor does not operate.)	Blown out	Check the conduction of the fuse. When no conduction, check the cause and then replace the fuse.	Short circuit of the control circuit, burnout of electrical part	Refer to the items related to the electrical part in failure.
			Over current due to defective operation of Electromagnetic contactor	Refer to the items of Electromagnetic Contactor.

(to be continued)

Troubleshooting (continued)

Upper/Lower Limit Switch

Symptom	Cause	Remedy	Main factor	Countermeasure
Electric chain hoist does not operate. (Electromagnetic Contactor or VFD does not operate.)	Contact point fusing	Actuate the limit switch manually to check the conduction of the contact points. Replace the limit switch as a whole when no conduction.	Habitual use of the limit switch	Do not use the limit switch habitually.
	Breakage	Check the wiring. Repair or replace the limit switch as a whole if the limit switch has no conduction.	Vibration, impact	Use the electric chain hoist avoiding the impact.
	Moving part rusted shut (defective return action of the moving part)	Check the moving part of the limit switch such as actuator lever is not stiff. If it is stiff, remove the rust or replace the stiff part.	Leaving the electric chain hoist for a long time at the upper/lower limit.	Do not leave the electric chain hoist at the upper/lower limit.
Electric chain hoist does not stop at the upper/lower limit.	Contact point welding	Actuate the limit switch manually to check the conduction of the contact points. Replace the limit switch as a whole when it does not turn off.	Habitual use of the limit switch	Do not use the limit switch habitually.
	Moving part rusted shut	Check the moving part of the limit switch such as actuator lever is not stiff. If it is stiff, remove the rust or replace the stiff part.	No use for a long time, use in an environment with rich moisture	Check the electric chain hoist regularly.
	Wrong wiring	Check the wiring in accordance with the wiring diagram. Perform the wiring correctly. If the wiring of the limit switch is correct, the cause is in the negative phase connection. Change two wires of the power line.	Wrong wiring	Correct the wiring in accordance with the wiring diagram.

Push Button Switch

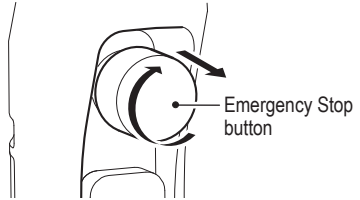
Symptom	Cause	Remedy	Main factor	Countermeasure
Electric chain hoist does not operate. (Electromagnetic Contactor does not operate.)	Emergency Stop button is pressed to its end and locked.	When the Emergency Stop button is pressed and locked, turn it clockwise to release the lock. 	Forgot releasing the Emergency Stop button	Read "How to operate the push button" (P20) and use the electric chain hoist.
	Faulty switch unit	Check the conduction of the contact points. Replace the Push Button Switch if it has no conduction.	Vibration, impact	Use the electric chain hoist avoiding the impact.
	Breakage inside the switch	Check that the Push Button Switch cord is connected with the switch unit correctly. Repair the cord if it has no conduction.	Vibration, impact	Use the electric chain hoist avoiding the impact.
	Loosened terminal screw inside the switch unit	Tighten the screw if loosened	Vibration, impact	Use the electric chain hoist avoiding the impact.
	Wire breakage of Push Button Switch Cord	Check the conduction of the Push Button Switch Cord. If it has no conduction, replace the cable, or the Push Button Switch Cord as a set.	Damage of cable cover	Operate the electric chain hoist not to impede with other facility.
External force applied on the cable due to improper tying of the protection wire			Tie the protection wire securely. (See "Cable Connection" (P55).)	
The electric chain hoist does not operate as indicated.	Wrong wiring	Check the wiring in accordance with the wiring diagram. Perform the wiring correctly. If the wiring of the Push Button Switch is correct, the cause is in the negative phase connection. Change two wires of the power line.	Wrong wiring	Correct the wiring in accordance with the wiring diagram.
	Wrong affixing of N-E-S-W label	Affix the label in the correct direction.	Affixing the label in an improper direction	Affix the label correctly.
Electric chain hoist does not stop even if the Push Button is released	Defective return action of the switch unit	Replace the Push Button Switch if it does not operate smoothly.	Vibration, impact	Use the electric chain hoist avoiding the impact.

Troubleshooting (continued)

VFD

Symptom	Cause	Remedy	Main factor	Countermeasure
Electric chain hoist does not operate.	VFD failure	Reset the VFD by pressing Emergency Stop button. If the VFD still does not operate, check it.	VFD failure	Check the error code indicated by VFD referring to the "VFD Manual".
	Motor overheat	Stop by motor thermal relay function of the VFD Motor resumes operation when the VFD is reset by pressing the Emergency Stop after cool down.	Operation exceeding short time rating or intermittent rating	Check the short time rating and intermittent rating. Use the electric chain hoist within these ratings.
	VFD overheat	Stop by overheat preventive function of the VFD Motor resumes operation when the VFD is reset by pressing the Emergency Stop after cool down.	Operation exceeding short time rating or intermittent rating	Check the short time rating and intermittent rating. Use the electric chain hoist within these ratings.
	Expired service life of the VFD (capacitor)	Refer to the "VFD Manual".	Operation exceeding short time rating or intermittent rating	Check the short time rating and intermittent rating. Use the electric chain hoist within these ratings.

Interface Board

Symptom	Cause	Remedy	Main factor	Countermeasure
Electric chain hoist does not operate.	Damaged circuit component	Press the Push Button to check whether LED on the board lights or not. If LED does not light, replace the board. * This test is carried out with energizing the VFD. Be careful about electric shock.	Over current, over voltage, service life expiry	Operate the electric chain hoist at the rated voltage. Replace the Interface Board.
	Contact failure of connector	Check the conduction of the connector. Replace the connector if it has no conduction.	Defective assembling of the connector	Crimp and insert the connector pins securely.

Braking Resistor

Symptom	Cause	Remedy	Main factor	Countermeasure
Electric chain hoist does not operate.	Resistor breakage	Measure the resistance of the resistor. Replace the resistor if the resistance is infinity.	Operation exceeding short time rating or intermittent rating, over load	Use the electric chain hoist within the ratings.

Electric shock

Symptom	Cause	Remedy	Main factor	Countermeasure
Electric shock when touching the body and Push Button Switch	Improper grounding	Measure the grounding resistance. If it exceeds 100 Ω, perform grounding work in accordance with the relevant laws and regulations.	Defective grounding work	Perform the grounding work securely.
			Contact failure of the grounding wire	Connect the grounding wire securely without loosened screw
			Breakage of grounding wire	Layout the grounding wire to avoid the stress applied on it. (See the item of Power Cable and Push Button Switch.)
	Attachment of waterdrop	Remove the waterdrop, dry the electric chain hoist and then use it.	Operation by wet hand	Do not operate the electric chain hoist by wet hand.

Friction Clutch

⚠ DANGER



- **Do not adjust/disassemble the Friction Clutch.**

Adjusting or disassembling the Friction Clutch may result in death or serious injury.

Prohibited

Symptom	Cause	Remedy	Main factor	Countermeasure
Unable to lift a load, or the load lowers after stop.	Clutch is activated (normal)	Lighten the load less than the rated load and use the electric chain hoist.	Over load	Use the electric chain hoist with a load less than the rated load.
	Abrasion of Clutch Disk	Replace the Friction Clutch.	Too many use of the Friction Clutch	Avoid the over load.
			Approaching service life limit	Do not use the body exceeding the service limit.
	Secular change in mechanical characteristics of the Friction Clutch			Use of oil other than the designated oil
<p style="text-align: center;">⚠ DANGER</p> <div style="display: flex; align-items: center;">  <ul style="list-style-type: none"> • Use KITO genuine gear oil. (The gear oil for Friction Clutch with Mechanical Brake is different from the standard specification oil.) <p>Mandatory Use of the oil other than KITO genuine oil may result in death or serious injury due to the drop of a lifted load.</p> </div>				
	Temperature rise inside the gear box	Resume the operation after cool down. When it is still unable to lift a load, replace the Friction Clutch.	Leaving the electric chain hoist for a long time without use Use in a hot environment, or excessively frequent use	Pay attention to the place to use and the storage place. Avoid the use in a hot environment or excessively frequent use.

(to be continued)

Troubleshooting (continued)

Friction Clutch with Mechanical Brake

⚠ DANGER



Prohibited

- Do not adjust/disassemble the Friction Clutch with Mechanical Brake.

Adjusting or disassembling the Friction Clutch with Mechanical Brake may result in death or serious injury.

Symptom	Cause	Remedy	Main factor	Countermeasure
Unable to lift a load.	Clutch is activated (normal)	Lighten the load less than the rated load and use the electric chain hoist.	Over load	Use the electric chain hoist with a load less than the rated load.
	Abrasion of Clutch Disk	Replace the Friction Clutch with Mechanical Brake.	Too many use of the Friction Clutch	Avoid the over load.
			Use of oil other than the designated oil	Use KITO genuine oil.
	Change in mechanical characteristics of the Friction Clutch with Mechanical Brake		Leaving the electric chain hoist for a long time without use	Do not use the body exceeding the service limit.
Temperature rise inside the gear box	Resume the operation after cool down. When it is still unable to lift a load, replace the Friction Clutch with Mechanical Brake.	Use in a hot environment, or excessively frequent use	Avoid the use in a hot environment or excessively frequent use.	
Unable to lift a load, or the load lowers after stop.	Deteriorated braking performance	Replace the Friction Clutch with Mechanical Brake.	Use of oil other than the designated oil	Use KITO genuine oil.
	Abrasion of the Clutch Disk		Approaching service life limit	Do not use the body exceeding the service limit.
Electric chain hoist of VFD specification became tripped frequently at lowering a load.	Abrasion of the Clutch Disk	When the electric chain hoist trips frequently, replace the Friction Brake with Mechanical Brake with a new one.	Approaching service life limit	Do not use the body exceeding the service limit.

⚠ DANGER





Mandatory

- Use KITO genuine gear oil. (The gear oil for Friction Clutch with Mechanical Brake is different from the standard specification oil.)

Use of the oil other than KITO genuine oil may result in death or serious injury due to the drop of a lifted load.

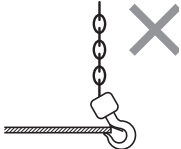
Hook

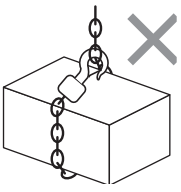
Symptom	Cause	Remedy	Main factor	Countermeasure
Widened Hook opening	Deformation of the Hook	Replace the Hook if the deformation exceeds the criteria. (See P70.)	Over load	Use the electric chain hoist with a load less than the capacity.
			Earth lifting	Do not carry out earth lifting. Be careful not to impede the Hook with protruding object during lifting.
			Slinging a load at the tip of the Hook.  Lateral pulling of the Hook	Sling a load at the center of the Hook
			Improper slinging	Angle formed by two slings must be 120 degrees or less.  120 degrees or less
			Use of the sling with a size improper to the Hook	Use the proper sling.
Twisted hanging of the Hook			Use of the Hook with the Load Chain wound on a load 	Do not wind the Load Chain directly on a load.
Hook unable to swivel smoothly at the neck	Rusting shut or corrosion of Bearing	Swivel the Hook at the neck by hand. If it is difficult to swivel smoothly, overhaul or replace the Bearing.	Insufficient grease application, corrosion due to environment of use	Apply grease regularly. Use the sling to avoid the dipping of the Hook into chemicals.
	Damaged Bearing		Intrusion of dust	Be careful about the intrusion of foreign matter into the neck.

(to be continued)

Troubleshooting (continued)

Hook (continued)

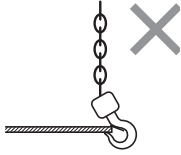
Symptom	Cause	Remedy	Main factor	Countermeasure
Hook Latch has come off	Deformation of the Hook	Replace the Hook if the deformation exceeds the criteria. (See P70.)	Over load	Use the electric chain hoist with a load less than the capacity.
			Earth lifting	Do not carry out earth lifting. Be careful not to impede the Hook with protruding object during lifting.
			Use of the sling with a size improper to the Hook	Use the proper sling.
	Deformation and come-off of the Hook Latch	Replace the Hook Latch if it has come off or is deformed.	Sling put on the Hook Latch	Do not put the sling on the Hook Latch.
Hook bent at the neck (shank)	Deformation or damage of the Hook at its neck	Replace the Hook bent at the neck	Lifting a load at the tip of the Hook  Lateral pulling of the Hook	Sling a load at the center of the Hook
Hook unable to swivel smoothly at the neck	Rusting shut or corrosion of Bearing	Swivel the Hook at the neck by hand. If it is difficult to swivel smoothly, overhaul or replace the Bearing.	Insufficient grease application, corrosion due to environment of use	Apply grease regularly. Use the sling to avoid the dipping of the Hook into chemicals.
	Damaged Bearing		Intrusion of dust	Be careful about the intrusion of foreign matter into the neck.

Load Chain

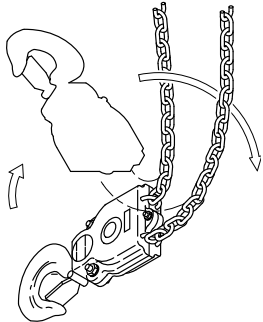
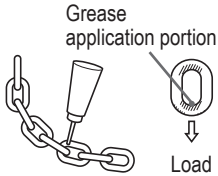
Symptom	Cause	Remedy	Main factor	Countermeasure
Twisted Load Chain	Capsized Bottom Hook	Turn over the Bottom Hook to the original position to cancel the capsizing. 	Bottom Hook was turned over by one turn during working.	When using multi fall model hoist, check that the Hook is not capsized before use.
	Load Chain is twisted inside the main body of the electric chain hoist.	Remove the Chain Guide A and the Load Chain, and then reassemble them.	Improper assembling	Assemble the electric chain hoist correctly. (See Disassembling/Assembling Manual)
Sudden activation of the Friction Clutch when lowering	Knot of the Load Chain due to entanglement in the Chain Container	Check the capacity of the Chain Container (with the nameplate on the Chain Container). If insufficient, replace the Chain Container with a larger capacity.	Insufficient capacity of the Chain Container	When installing the electric chain hoist, check the lift and the capacity of the Chain Container, and assemble them correctly.
Popping sound	Abrasion of the Load Chain links	Measure the abrasion of wire diameter. Replace the Load Chain if it reaches at the abrasion limit. (See P69)	Long hour operation without grease	Apply lubricant regularly. (See P40) 
			Excessive inching operation	Do not perform excessive operation.
			Over load	Use the electric chain hoist with a load less than the capacity.
			Pulling a load in an inclined direction	Do not pull a load in an inclined direction.
	Abrasion of Load Sheave, Idle Sheave	Refer to the item of Load Sheave, Idle Sheave.		
Elongation of pitch	Measure the sum of pitches of 5 links. Replace the Load Chain if this value exceeds the limit value. (See P69)	Over load	Use the electric chain hoist with a load less than the capacity.	

(to be continued)

Troubleshooting (continued)

Load Chain (continued)

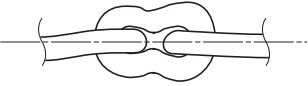
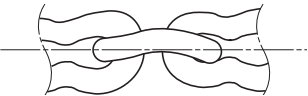
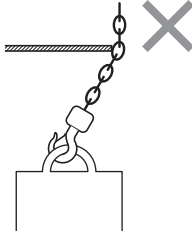
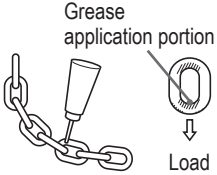
Symptom	Cause	Remedy	Main factor	Countermeasure
Irregular noise	Flaw and deformation of the Load Chain surface	Replace the Load Chain with apparent flaw or deformation. 	Use of the Load Chain without canceling capsized state	When using multi fall model hoist, check that the Hook is not capsized before use.
	Hit flaw on the Load Chain surface		Use of the Load Chain as twisted Hit with other object strongly 	Assemble the electric chain hoist correctly. (See Disassembling/Assembling Manual) Use the electric chain hoist carefully paying attention not to impede with other object.
Surface losing lustre and discolored	Rusting and corrosion	Remove rust and apply oil. Replace the Load Chain if the rust and corrosion is apparent.	Run-out of oil	Apply lubricant regularly. (See P40) 
			Use of electric chain hoist exposed to rain	Store the electric chain hoist indoor or under the roof when not using.
			Influence of sea water and chemicals	Contact KITO for the use in special environment in advance. Use the electric chain hoist correctly within the scope guaranteed by the manufacturer.
Breakage of the Load Chain	Expiry of the service life	Check the Load Chain and replace it if exceeded the criteria. (See P69)	Mechanical service life expiry	Handle the Load Chain correctly and perform the appropriate control including daily inspection and inspection.

Load Sheave, Idle Sheave

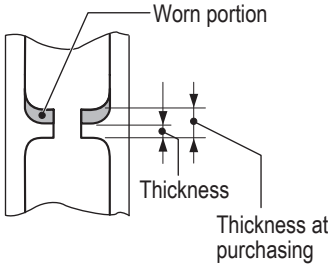
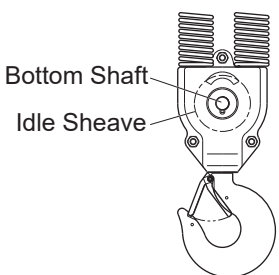
Symptom	Cause	Remedy	Main factor	Countermeasure																																				
Popping sound 	Abrasion of sheave pocket or flaw by the Load Chain out of mesh with the Sheave	Measure the thickness of the crest. Replace the Sheave if the thickness is less than the service limit. (The Load Chain may be worn. Check also the Load Chain.) Service limit	Long hour operation without grease, expiry of service life Excessive inching operation Over load	Apply lubricant regularly. (See P40) Do not perform excessive operation. Use the electric chain hoist with a load less than the capacity.																																				
		<table border="1"> <thead> <tr> <th rowspan="2">Code</th> <th rowspan="2">Capacity (t)</th> <th colspan="2">Thickness (mm)</th> </tr> <tr> <th>Standard</th> <th>Limit</th> </tr> </thead> <tbody> <tr> <td>ER2-001H/IH/HD</td> <td>125kg</td> <td rowspan="2">1.5</td> <td rowspan="2">1.0</td> </tr> <tr> <td>ER2-003S/IS/SD</td> <td>250kg</td> </tr> <tr> <td>ER2-005L/IL/LD</td> <td rowspan="2">500kg</td> <td rowspan="2">3.0</td> <td rowspan="2">2.0</td> </tr> <tr> <td>ER2-005S/IS/SD</td> </tr> <tr> <td>ER2-010L/IL/LD</td> <td rowspan="2">1</td> <td rowspan="2">4.5</td> <td rowspan="2">3.0</td> </tr> <tr> <td>ER2-010S/IS/SD</td> </tr> <tr> <td>ER2-015S/IS/SD</td> <td rowspan="2">1.5</td> <td rowspan="2">6.5</td> <td rowspan="2">4.3</td> </tr> <tr> <td>ER2-020L/IL/LD</td> </tr> <tr> <td>ER2-020S/IS/SD</td> <td rowspan="2">2</td> <td rowspan="2">7.3</td> <td rowspan="2">4.9</td> </tr> <tr> <td>ER2-030S/IS/SD</td> </tr> <tr> <td>ER2-025S/IS/SD</td> <td rowspan="2">2.5</td> <td rowspan="2">7.3</td> <td rowspan="2">4.9</td> </tr> <tr> <td>ER2-050S/IS/SD</td> <td>5</td> </tr> </tbody> </table>	Code	Capacity (t)	Thickness (mm)		Standard	Limit	ER2-001H/IH/HD	125kg	1.5	1.0	ER2-003S/IS/SD	250kg	ER2-005L/IL/LD	500kg	3.0	2.0	ER2-005S/IS/SD	ER2-010L/IL/LD	1	4.5	3.0	ER2-010S/IS/SD	ER2-015S/IS/SD	1.5	6.5	4.3	ER2-020L/IL/LD	ER2-020S/IS/SD	2	7.3	4.9	ER2-030S/IS/SD	ER2-025S/IS/SD	2.5	7.3	4.9	ER2-050S/IS/SD	5
Code	Capacity (t)	Thickness (mm)																																						
		Standard	Limit																																					
ER2-001H/IH/HD	125kg	1.5	1.0																																					
ER2-003S/IS/SD	250kg																																							
ER2-005L/IL/LD	500kg	3.0	2.0																																					
ER2-005S/IS/SD																																								
ER2-010L/IL/LD	1	4.5	3.0																																					
ER2-010S/IS/SD																																								
ER2-015S/IS/SD	1.5	6.5	4.3																																					
ER2-020L/IL/LD																																								
ER2-020S/IS/SD	2	7.3	4.9																																					
ER2-030S/IS/SD																																								
ER2-025S/IS/SD	2.5	7.3	4.9																																					
ER2-050S/IS/SD				5																																				
The Idle Sheave does not rotate smoothly	Abrasion and flaw of the Needle Bearing for Idle Sheave or Bottom Shaft.	Replace the Needle Bearing or Bottom Shaft if it is worn or damaged. 	Long hour operation without grease, expiry of service life Excessive inching operation Over load	Apply lubricant regularly. (See P91) Do not perform excessive operation. Use the electric chain hoist with a load less than the capacity.																																				
			Pulling a load in an inclined direction	Do not pull a load in an inclined direction.																																				

Chain Guide A

Symptom	Cause	Remedy	Main factor	Countermeasure
Swinging of a load became larger than when purchasing	Such as the wear of the cross-shaped holes that guide the chain.	<ul style="list-style-type: none"> • Replace the Chain Guide if the cross-shaped hole that guides the chain is significantly worn, deformed, or damaged. • Replace the Chain Guide if it has dents caused by the chain. • At this time, check the Load Chain as well because it may also be worn. 	Pulling a load in an inclined direction	Do not pull a load in an inclined direction.

Load Gear, Gear B, Pinion, Motor Shaft

Symptom	Cause	Remedy	Main factor	Countermeasure
Unable to lift a load.	Abrasion, Damage	Visually check the teeth and spline, and replace parts if they are significantly worn or damaged. After replacing the parts, also replace the oil and apply grease to the spline (joint part).	Long hour operation without oil <div style="border: 1px solid black; padding: 5px; margin-top: 5px;"> <p style="text-align: center;">⚠ DANGER</p> <p>! Mandatory</p> <ul style="list-style-type: none"> • Use KITO genuine gear oil. (The gear oil for Friction Clutch with Mechanical Brake is different from the standard specification oil.) <p>Use of the oil other than KITO genuine oil may result in death or serious injury due to the drop of a lifted load.</p> </div>	Keep the oil change cycle. (See P90)
			Long hour operation without grease (motor joint)	Apply grease regularly. (See P92)
Irregular motion	Partial abrasion or damage		Too many use of the Friction Clutch	Avoid the over load.
			Habitual use of Upper/Lower Limit Switch	Do not use Upper/Lower Limit Switch habitually.

Troubleshooting (continued)

Bearing

Symptom	Cause	Remedy	Main factor	Countermeasure
Unable to lift a load.	Sticking, Breakage	<ul style="list-style-type: none"> Replace the bearing with harmful defects such as significant abrasion, deformation, scratches and breakage. Turn the bearing by hand and replace the bearing if it does not rotate smoothly. 	Use under hot environment or excessively frequent use	Avoid using under hot environment or excessively frequent use
Abnormal noise	Deterioration			

Traveling motion of the Trolley (common for motorized/manual trolley)

Symptom	Cause	Remedy	Main factor	Countermeasure
Unable to travel due to slipping of wheel	Inclination of Travel Rail	Make sure that rail gradient is within 1 degree.	Improper installation of Travel Rail	Install the Travel Rail correctly.
Unable to travel due to slipping of wheel, or unable to travel in uniform motion	Oil attachment on running surface of the rail	Wipe off the attached foreign matter.	Use under the environment likely to attach foreign matter	Clean the Travel Rail regularly.
Abrasion sound when running on a curved rail	Friction resistance between wheel and rail	Apply small amount of oil on the rail surface where noise generates.		
Unable to travel on the curved rail	Interference of the trolley and the curved rail	Make sure that the rail curvature is larger than the minimum turning radius.	Use of the curved rail of curvature less than minimum turning radius	Do not use the curved rail of curvature less than minimum turning radius
Unable to travel due to wheel floating	Pulling a load in an inclined direction (floating wheel)	—	Operating method	Use the electric chain hoist correctly.
Wheel unable to rotate	Defective gear engagement	Remove the stain and foreign matter on the wheel and the gear.	Ambient conditions, environment	Check regularly.
Serpentine motion Abnormal noise Unable to travel smoothly	Wrong adjustment of collar	Check the number of collars and their assembled positions	Incomplete checking	Assemble correctly.
	Uneven abrasion of the wheel	Check the abrasion of the wheel	Traveling on curved rail or unevenness of running surface	Check regularly.
	Deformation of wheel	Check the distortion of wheel and damage of running surface	Excessively frequent collision with stopper or unevenness of running surface	Replace the wheel Use the electric chain hoist correctly.

Traveling motion of the Trolley (common for motorized/manual trolley) (continued)

Serpentine motion Abnormal noise Unable to travel smoothly (continued)	Deterioration of wheel bearing	Check if rolling noise sounds when the wheel is rotating.	Expiry of service life	Replace the wheel bearing.
	Deformation and abrasion of the rail	Check the abrasion and deformation of the rail.	Over load or expiry of service life	Replace the rail. Use the electric chain hoist correctly.
	Poor mating between gears	Check the lubrication status of the mating section of the gears.	Insufficient lubrication	Lubricate periodically.

Traveling motion of the Trolley (only for motorized trolley)

Symptom	Cause	Remedy	Main factor	Countermeasure
Wheel unable to rotate	Locking of brake	Disassemble the motor cover. Remove rust and stains.	Ambient conditions, environment	Check regularly.
	Electric system failure (Refer to the items of Electric chain hoist)	(Refer to the items of Electric chain hoist)		
Serpentine motion Abnormal noise	Abrasion of the side roller	Check the abrasion	Traveling on curved rail or expiry of service life	Check regularly.
	Abrasion of the Brake Pad	Check the abrasion of the Brake Pad	Expiry of service life	Check regularly.
The traveling motor has abnormal noise	Abrasion and flaw of gears and motor shaft	<ul style="list-style-type: none"> • Visually check the teeth and spline, and replace parts if they are significantly worn or damaged. • After replacing the parts, also replace the grease. 	<ul style="list-style-type: none"> • Service life expiry • Long hour operation without sufficient grease 	Apply grease regularly.

Traveling motion of the Trolley (only for manual trolley)

Symptom	Cause	Remedy	Main factor	Countermeasure
Unable to pull the Hand Chain	Defective engagement of the Hand Wheel and the Hand Chain	Engage the Hand Chain with the Hand Wheel correctly.	Rapid operation	Replace the Hand Chain with abrasion or deformation.

Appendix

This Appendix summarizes the information helpful for the use of KITO electric chain hoist, such as optional parts, technical materials and service network.

■ Optional Parts.....	122
■ Product Structure and Names of Each Part	124
■ Technical Material	126
• Hook Dimensions (for ER2)	126
• Table of Lifting Load.....	126
• Rated Motor Current.....	126
• Conversion Table between Lift/Travel/Speed.....	128
• Clearance between Trolley and Applicable Rail.....	129
• Wiring Diagram of Single Speed ER2/ER2SP/ER2SG	130
• Wiring Diagram of Dual Speed ER2/ER2SP/ER2SG	133
• Wiring Diagram of Single Speed ER2M	136
• Wiring Diagram of Dual Speed ER2M	139
■ Daily Inspection Check Sheet.....	142
■ Monthly Inspection Check Sheet.....	144
■ Annual Inspection Check Sheet	146

Optional Parts

Friction Clutch with Mechanical Brake

KITO's original friction clutch equipped with mechanical brake

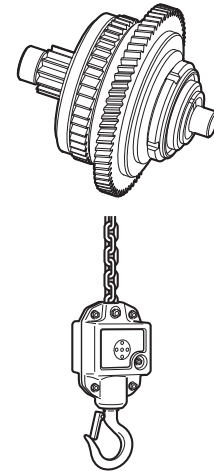

Load Bell: Over load alarm

An alarm unit to detect over load

Detection load: 100 to 110 % of the capacity

Alarm sound level: 85 dB or more



NR Relay: Negative Phase Connection Preventive Device

A device to detect the negative phase connection and open phase connection immediately and shut down the power automatically.

T-shape cable hanger: Attachment for power feeding

Code	Travel Rail width (mm)	Hole pitch
T-shape cable hanger 100	75	A : (53mm)
	100	B : (78mm)
	125	C : (103mm)
	150	D : (128mm)
T-shape cable hanger 175	175	A : (153mm)

- Contact KITO when the Travel Rail width exceeds 175 mm.

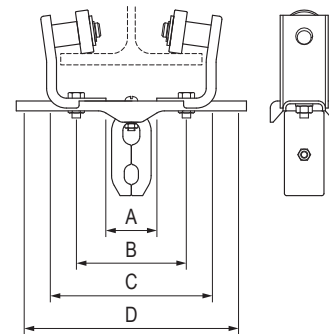

● Cable hanger Pusher

< Manual Trolley 125 kg to 3 t >

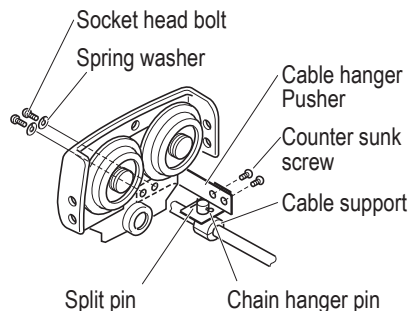

< Manual Trolley 5 t >

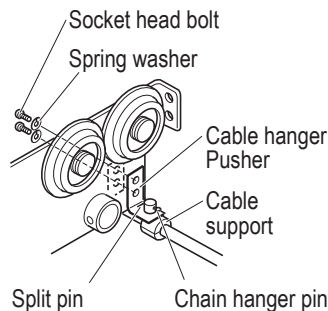

< MR2 >

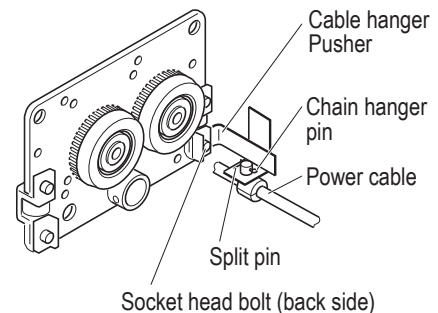

■ Angle Suspender: Accessory for power feeding

Code	Angle	Hole pitch
THLT and THLP	50×50	53 mm
	65×65	66 mm
	75×75	79 mm

< THLT (for intermediate support) > < THLP (for Push Button Switch cord) >

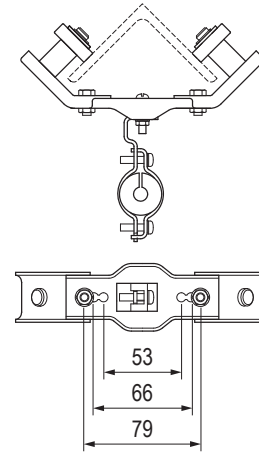
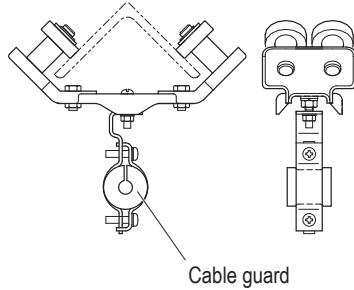
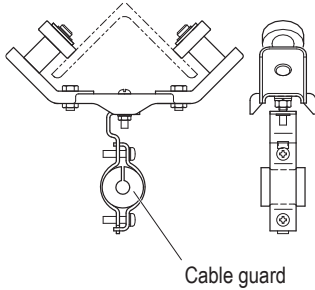

■ End Suspender

Capacity	Code	Part number	Part name	Part code	Note
125kg 250kg	ER2-001H ER2-001IH ER2-001HD ER2-003S ER2-003IS ER2-003SD	408	Chain End Suspender	ER2BS9408	
		417	Socket Bolt	J1BE1-0806528	
		418	Lever Nut	C2BA100-9074	
		396	Socket Bolt	J1BE1-0503012	
		397	U Nut	E2DBX10S9853	
		399	Plain Washer	J1WD011-00050	
		500kg	ER2-005S ER2-005L ER2-005IS ER2-005SD ER2-005IL ER2-005LD	408	Chain End Suspender
417	Socket Bolt			J1BE1-0807528	
418	Lever Nut			C2BA100-9074	
396	Socket Bolt			J1BE1-0604018	
397	U Nut			E5SE003S9855	
399	Plain Washer			J1WD011-00060	
1t	ER2-010S ER2-010L ER2-010IS ER2-010SD ER2-010IL ER2-010LD			408	Chain End Suspender
		417	Socket Bolt	J1BE1-0809012	
		418	Lever Nut	C2BA100-9074	
		396	Socket Bolt	J1BE1-0804013	
		397	U Nut	C2BA100-9074	

Capacity	Code	Part number	Part name	Part code	Note		
1.5t 2t	ER2-015S ER2-015IS ER2-015SD ER2-020S ER2-020L ER2-020IS ER2-020SD ER2-020IL ER2-020LD	408	Chain End Suspender	ER2ES9408			
		417	Socket Bolt	J1BE1-1010532			
		418	Lever Nut	C2BA200-9074			
		396	Socket Bolt	J1BE1-0804013			
		397	U Nut	C2BA100-9074			
		2.5t	ER2-025S ER2-025IS ER2-025SD	408	Chain End Suspender	ER1ES9408	
				417	Socket Bolt	J1BE1-1008532	
418	Lever Nut			C2BA200-9074			
396	Socket Bolt			J1BE1-1006032			
397	U Nut			C2BA200-9074			
3t	ER2-030S ER2-030IS ER2-030SD	417	Socket Bolt	J1BE1-1010532	*		
		418	Lever Nut	C2BA200-9074			
5t	ER2-050S ER2-050IS ER2-050SD	417	Socket Bolt	J1BE1-1008532	*		
		418	Lever Nut	C2BA200-9074			

* Chain End Suspender is not used for double chain fall type due to the orientation of the chain.
For double chain fall type, attach the terminal chain directly to Chain Guide A.

Product Structure and Names of Each Part

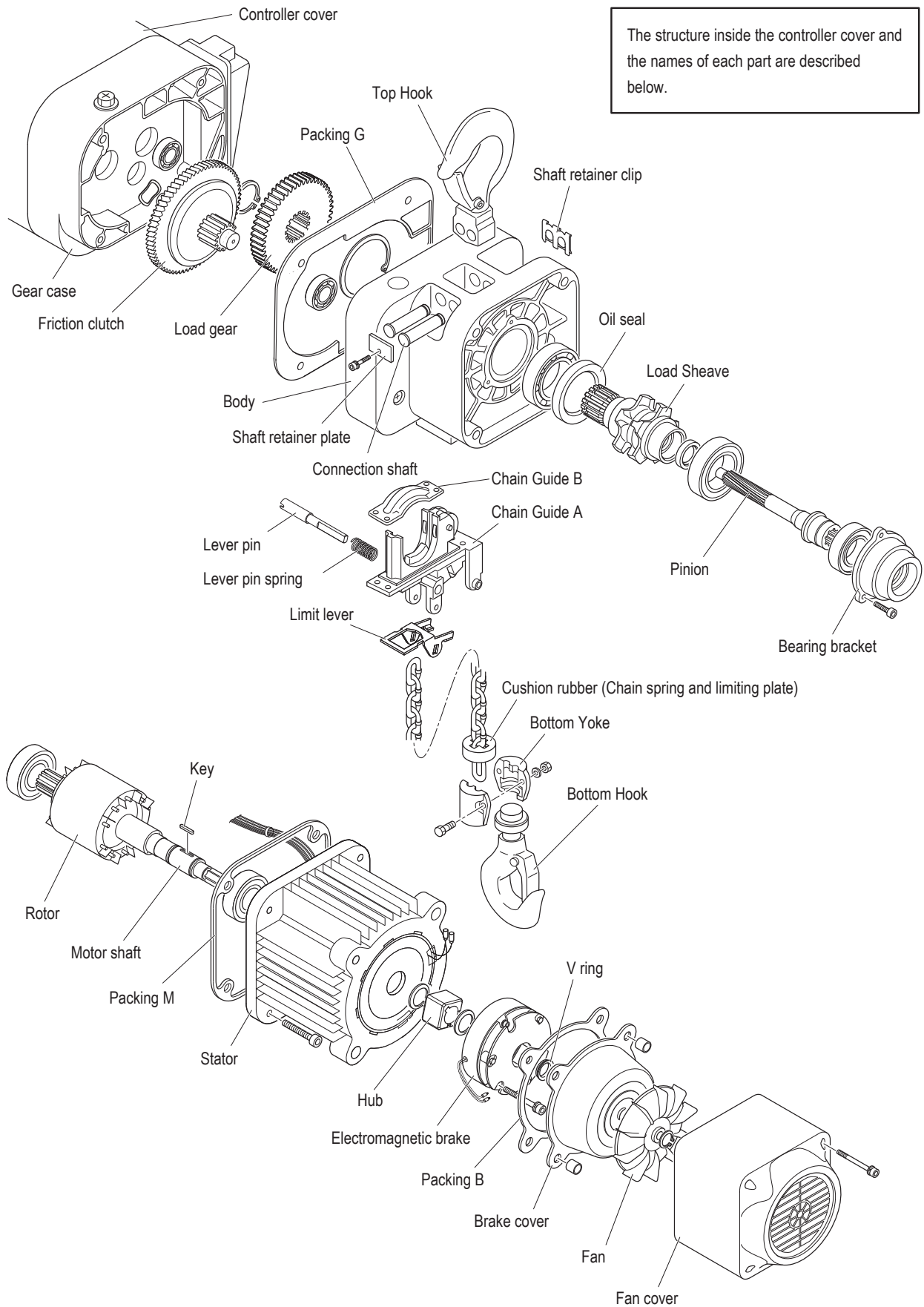

Single Speed Model
 (500V Class Dual Speed Model)

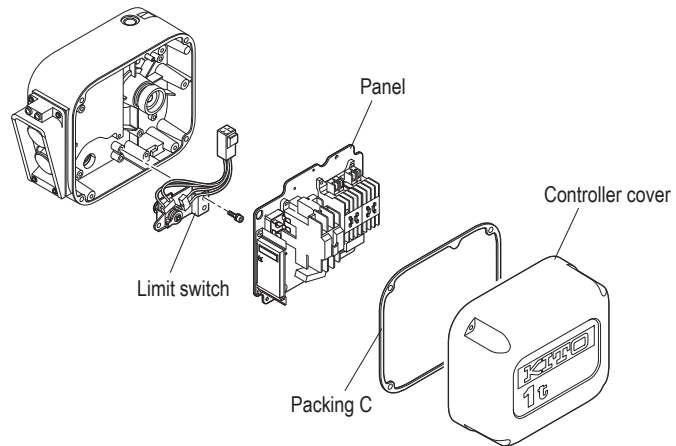

Dual Speed VFD Model (Body size B, C)

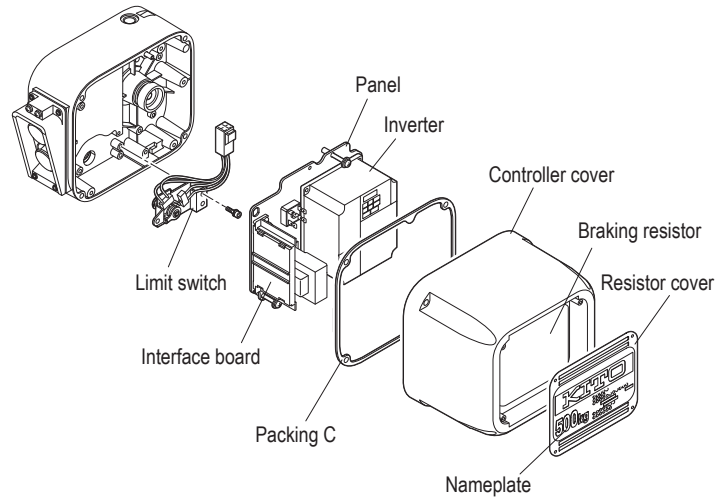

Dual Speed VFD Model (Body size D, E, F)

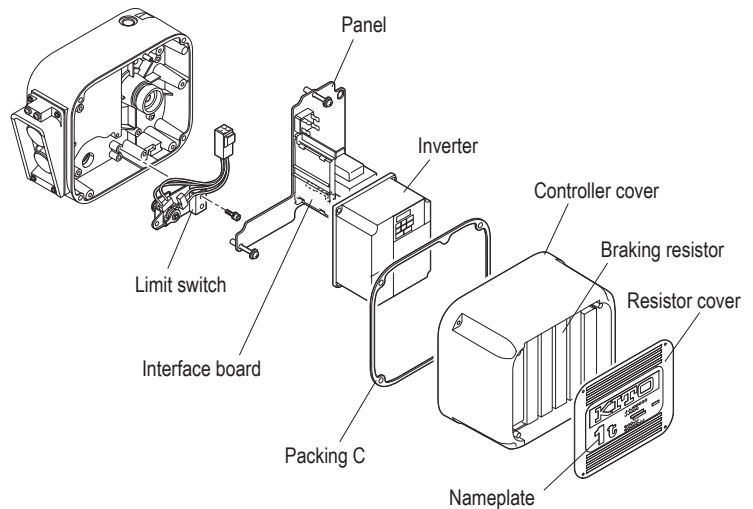

Technical Material

Hook Dimensions (for ER2)

● Top Hook

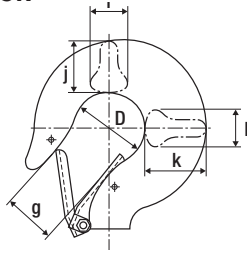

● Bottom Hook

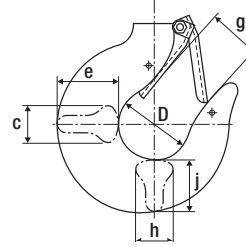

Code	Top Hook (mm)						Bottom Hook (mm)											
	D	g	i	j	k	l	D	g	h	j	e	c						
ER2-001H/IH/HD	35.5	27.0	17.5	23.5	28.0	17.5	35.5	27.0	17.5	23.5	28.0	17.5						
ER2-003S/IS/SD																		
ER2-005L/IL/LD																		
ER2-005S/IS/SD																		
ER2-010L/IL/LD	42.5	31.0	22.5	31.0	36.5	22.5	42.5	31.0	22.5	31.0	36.5	22.5						
ER2-010S/IS/SD																		
ER2-015S/IS/SD	53.0	39.0	31.5	43.5	51.5	31.5	47.5	34.0	26.5	36.5	43.5	26.5						
ER2-020L/IL/LD							53.0	39.0	31.5	43.5	51.5	31.5	53.0	39.0	31.5	43.5	51.5	31.5
ER2-020S/IS/SD																		
ER2-025S/IS/SD	60.0	44.0	32.5	44.0	52.0	32.5	60.0	44.0	34.5	47.5	56.0	34.5						
ER2-030S/IS/SD			34.5	47.5	56.0	34.5												
ER2-050S/IS			42.5	56.0	67.0	42.5							63.0	47.0	42.5	56.0	67.0	42.5

Table of Lifting Load

Capacity (t)	125kg	250kg	500kg	1	1.5	2	2.5	3	5
Lifting Load (t)	0.126	0.251	0.501	1.002	1.504	2.004	2.504	3.005	5.014

Note) Above figures are for the standard specification Hook for Electric Chain Hoist ER2.

Rated Motor Current

■ Lifting motor (Single speed)

(Unit:A)

Capacity (t)	Code	Motor output (kW)	230/460V Class		500V Class	
			208-230V	415-460V	500V	575V
			60Hz		50Hz	60Hz
125kg	ER2-001H	0.56	3.4	1.7	1.6	1.4
250kg	ER2-003S					
500kg	ER2-005L					
500kg	ER2-005S	0.9	4.8	2.5	2.0	1.8
1	ER2-010L					
1.5	ER2-010S	1.8	8.6	4.2	3.0	3.3
2	ER2-015S					
2	ER2-020L	1.8	8.6	4.2	3.0	3.3
2.5	ER2-020S					
2.5	ER2-025S	3.5	16.4	7.9	6.0	6.2
3	ER2-030S					
5	ER2-050S					
Motor Insulation Class			B		B	

■ Lifting motor (Dual speed)

(Unit:A)

Capacity (t)	Code	Motor output (kW)	230/460V Class		500V Class			
			208-230V	415-460V	Code	Motor output (kW)	500V	575V
			60Hz				50Hz	60Hz
125kg	ER2-001IH	0.56	3.6	1.8	ER2-001HD	0.5/0.13	1.6/0.9	1.4/0.9
250kg	ER2-003IS				ER2-003SD			
500kg	ER2-005IL				ER2-005LD			
1	ER2-005IS	0.9	5.1	2.7	ER2-005SD	0.9/0.23	1.8/1.4	1.7/1.4
	ER2-010IL				ER2-010LD			
1.5	ER2-010IS	1.8	9.1	4.5	ER2-010SD	1.8/0.45	3.2/2.2	3.2/2.0
	ER2-015IS				ER2-015SD			
2	ER2-020IL	1.8	9.1	4.5	ER2-020LD	1.8/0.45	3.2/2.2	3.2/2.0
	ER2-020IS				ER2-020SD			
2.5	ER2-025IS	3.5	17.3	8.3	ER2-025SD	3.5/0.88	6.0/3.7	6.0/3.4
3	ER2-030IS				ER2-030SD			
5	ER2-050IS				ER2-050SD			
Motor Insulation Class			B		-		B	

■ Traveling motor (Single speed)

(Unit:A)

Capacity (t)	Code	Motor output (kW)	230/460V Class		500V Class	
			208-230V	415-460V	500V	575V
			60Hz		50Hz	60Hz
125kg	MR2-010S/L	0.4	3.2	1.6	1.5	1.1
250kg						
500kg						
1						
1.5	MR2-020S/L	0.75	5.1	2.5	2.2	1.8
2						
2.5	MR2-030S/L	0.75	5.1	2.5	2.2	1.8
3						
5	MR2-050S/L	0.75	5.1	2.5	2.2	1.8
Motor Insulation Class			B		B	

■ Traveling motor (Dual speed)

(Unit:A)

Capacity (t)	Code	Motor output (kW)	230/460V Class		500V Class			
			208-230V	415-460V	Code	Motor output (kW)	500V	575V
			60Hz				50Hz	60Hz
125kg	MR2-010IS	0.4	3.4	1.7	MR2-010SD	0.32/0.08	1.7/1.0	1.1/0.8
250kg								
500kg					MR2-020SD			
1								
1.5	MR2-020IS	0.75	5.4	2.7	MR2-030SD	0.64/0.16	1.9/1.5	1.3/1.1
2								
2.5	MR2-030IS	0.75	5.4	2.7	MR2-050SD	0.64/0.16	1.9/1.5	1.3/1.1
3								
5	MR2-050IS	0.75	5.4	2.7	MR2-050SD	0.64/0.16	1.9/1.5	1.3/1.1
Motor Insulation Class			B		-		B	

(to be continued)

Technical Material (continued)

■ Conversion Table between Lift/Travel/Speed (m/s → m/min)

Converted value (m/s)	Conventional value (m/min)	Converted value (m/s)	Conventional value (m/min)	Converted value (m/s)	Conventional value (m/min)	Converted value (m/s)	Conventional value (m/min)	Converted value (m/s)	Conventional value (m/min)	Converted value (m/s)	Conventional value (m/min)
0.002	0.1	0.067	4.0	0.133	8.0	0.200	12.0	0.267	16.0	0.333	20.0
0.003	0.2	0.068	4.1	0.135	8.1	0.202	12.1	0.268	16.1	0.335	20.1
0.005	0.3	0.070	4.2	0.137	8.2	0.203	12.2	0.270	16.2	0.337	20.2
0.007	0.4	0.072	4.3	0.138	8.3	0.205	12.3	0.272	16.3	0.338	20.3
0.008	0.5	0.073	4.4	0.140	8.4	0.207	12.4	0.273	16.4	0.340	20.4
0.010	0.6	0.075	4.5	0.142	8.5	0.208	12.5	0.275	16.5	0.342	20.5
0.012	0.7	0.077	4.6	0.143	8.6	0.210	12.6	0.277	16.6	0.343	20.6
0.013	0.8	0.078	4.7	0.145	8.7	0.212	12.7	0.278	16.7	0.345	20.7
0.015	0.9	0.080	4.8	0.147	8.8	0.213	12.8	0.280	16.8	0.347	20.8
0.017	1.0	0.082	4.9	0.148	8.9	0.215	12.9	0.282	16.9	0.348	20.9
0.018	1.1	0.083	5.0	0.150	9.0	0.217	13.0	0.283	17.0	0.350	21.0
0.020	1.2	0.085	5.1	0.152	9.1	0.218	13.1	0.285	17.1	0.352	21.1
0.022	1.3	0.087	5.2	0.153	9.2	0.220	13.2	0.287	17.2	0.353	21.2
0.023	1.4	0.088	5.3	0.155	9.3	0.222	13.3	0.288	17.3	0.355	21.3
0.025	1.5	0.090	5.4	0.157	9.4	0.223	13.4	0.290	17.4	0.357	21.4
0.027	1.6	0.092	5.5	0.158	9.5	0.225	13.5	0.292	17.5	0.358	21.5
0.028	1.7	0.093	5.6	0.160	9.6	0.227	13.6	0.293	17.6	0.360	21.6
0.030	1.8	0.095	5.7	0.162	9.7	0.228	13.7	0.295	17.7	0.362	21.7
0.032	1.9	0.097	5.8	0.163	9.8	0.230	13.8	0.297	17.8	0.363	21.8
0.033	2.0	0.098	5.9	0.165	9.9	0.232	13.9	0.298	17.9	0.365	21.9
0.035	2.1	0.100	6.0	0.167	10.0	0.233	14.0	0.300	18.0	0.367	22.0
0.037	2.2	0.102	6.1	0.168	10.1	0.235	14.1	0.302	18.1	0.368	22.1
0.038	2.3	0.103	6.2	0.170	10.2	0.237	14.2	0.303	18.2	0.370	22.2
0.040	2.4	0.105	6.3	0.172	10.3	0.238	14.3	0.305	18.3	0.372	22.3
0.042	2.5	0.107	6.4	0.173	10.4	0.240	14.4	0.307	18.4	0.373	22.4
0.043	2.6	0.108	6.5	0.175	10.5	0.242	14.5	0.308	18.5	0.375	22.5
0.045	2.7	0.110	6.6	0.177	10.6	0.243	14.6	0.310	18.6	0.377	22.6
0.047	2.8	0.112	6.7	0.178	10.7	0.245	14.7	0.312	18.7	0.378	22.7
0.048	2.9	0.113	6.8	0.180	10.8	0.247	14.8	0.313	18.8	0.380	22.8
0.050	3.0	0.115	6.9	0.182	10.9	0.248	14.9	0.315	18.9	0.382	22.9
0.052	3.1	0.117	7.0	0.183	11.0	0.250	15.0	0.317	19.0	0.383	23.0
0.053	3.2	0.118	7.1	0.185	11.1	0.252	15.1	0.318	19.1	0.385	23.1
0.055	3.3	0.120	7.2	0.187	11.2	0.253	15.2	0.320	19.2	0.387	23.2
0.057	3.4	0.122	7.3	0.188	11.3	0.255	15.3	0.322	19.3	0.388	23.3
0.058	3.5	0.123	7.4	0.190	11.4	0.257	15.4	0.323	19.4	0.390	23.4
0.060	3.6	0.125	7.5	0.192	11.5	0.258	15.5	0.325	19.5	0.392	23.5
0.062	3.7	0.127	7.6	0.193	11.6	0.260	15.6	0.327	19.6	0.393	23.6
0.063	3.8	0.128	7.7	0.195	11.7	0.262	15.7	0.328	19.7	0.395	23.7
0.065	3.9	0.130	7.8	0.197	11.8	0.263	15.8	0.330	19.8	0.397	23.8
		0.132	7.9	0.198	11.9	0.265	15.9	0.332	19.9	0.398	23.9
										0.400	24.0
										0.500	30.0
										0.600	36.0

■ Clearance between Trolley and Applicable Rail

■ Motorized Trolley

(Unit:mm)

I-beam size			Clearance between trolley and rail									
			~1t		~2t		~3t			~5t		
							Single	Double				
H	B	t	A	B	A	B	A	A	B	A	B	
100	75	5	x	x	x	x	x	x	x	x	x	
125	75	5.5	13.8	9.75	x	x	x	x	x	x	x	
150	75	5.5	13.8	9.75	x	x	x	x	x	x	x	
180	100	6	14.2	22	18.6	19.5	x	x	x	x	x	
200	100	7	14.1	21.5	18.6	19	x	x	x	x	x	
150	125	8.5	11	33.25	15.4	30.75	x	x	x	x	x	
250	125	7.5	12.5	33.75	16.9	31.25	17.2	18.4	28.75	32.4	18.25	
250	125	10	5.9	32.5	10.3	30	10.6	11.8	27.5	25.8	17	
200	150	9	9.8	45.5	14.3	43	14.5	15.7	40.5	29.7	30	
300	150	8	12.9	46	17.3	43.5	17.6	18.8	41	32.8	30.5	
300	150	10	7.3	45	11.7	42.5	12.0	13.2	40	27.2	29.5	
300	150	11.5	3.7	44.25	8.2	41.75	8.5	9.7	39.25	23.7	28.75	
350	150	9	10.8	45.5	15.4	43	15.5	16.7	40.5	30.7	30	
350	150	12	1.7	44	6.2	41.5	6.4	7.6	39	21.6	28.5	
400	150	10	7.8	45	12.2	42.5	12.5	13.7	40	27.7	29.5	
400	150	12.5	x	x	5.1	41.25	5.4	6.6	38.75	20.6	28.25	
450	175	11	x	x	11.1	54.5	11.4	12.6	52	19.5	41.5	
450	175	13	x	x	4.5	53.5	4.3	5.5	51	26.6	40.5	
600	190	13	x	x	6.5	61	6.8	8	58.5	22.0	48	
600	190	16	x	x	x	x	x	x	x	11.9	46.5	

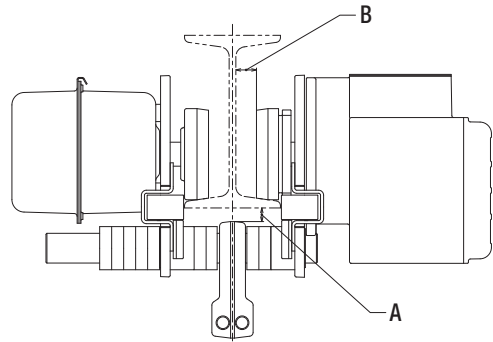

Technical Material

A

■ Manual Trolley

(Unit:mm)

I-beam size			Clearance between trolley and rail									
			TSP		TSP/TSG							
			~500kg		~1t		~2t		~3t		~5t	
H	B	t	A	B	A	B	A	B	A	B	A	B
100	75	5	13.3	12.5	21.1	11.0	x	x	x	x	x	x
125	75	5.5	10.8	12.25	19.5	10.75	x	x	x	x	x	x
150	75	5.5	10.8	12.25	19.5	10.75	x	x	x	x	x	x
180	100	6	11.2	24.5	19.9	23	25.6	18.5	x	x	x	x
200	100	7	11.1	24	19.9	22.5	25.6	18	x	x	x	x
150	125	8.5	7.9	35.75	16.7	34.25	22.4	29.75	24.1	27.25	x	x
250	125	7.5	9.4	36.25	18.2	34.75	23.9	30.25	25.6	27.75	35.2	20.25
250	125	10	2.9	35	11.6	33.5	17.3	29	19	26.5	28.6	19
200	150	9	6.8	48	15.6	46.5	21.2	42	22.9	39.5	32.5	32
300	150	8	9.8	48.5	18.6	47	24.3	42.5	26	40	35.6	32.5
300	150	10	4.2	47.5	13	46	18.7	41.5	20.4	39	30.5	31.5
300	150	11.5	x	x	9.5	45.25	15.2	40.75	16.9	38.25	26.4	30.75
350	150	9	7.8	48	16.6	46.5	22.2	42	23.9	39.5	33.5	32
350	150	12	x	x	7.5	45	13.1	40.5	14.8	38	24.4	30.5
400	150	10	4.7	47.5	13.5	46	19.2	41.5	20.9	39	30.5	31.5
400	150	12.5	x	x	6.4	44.75	12.1	40.25	13.8	37.75	23.4	30.25
450	175	11	3.6	59.5	12.4	58	18.1	53.5	19.7	51	29.3	43.5
450	175	13	x	x	5.3	57	11	52.5	12.7	50	22.3	42.5
600	190	13	x	x	7.8	64.5	13.5	60	15.2	57.5	24.8	50
600	190	16	x	x	x	x	3.4	58.5	5.1	56	14.7	48.5

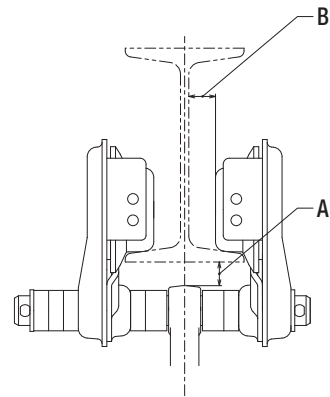

(to be continued)

Wiring Diagram of Single Speed ER2/ER2SP/ER2SG 575V (Plug Connection)

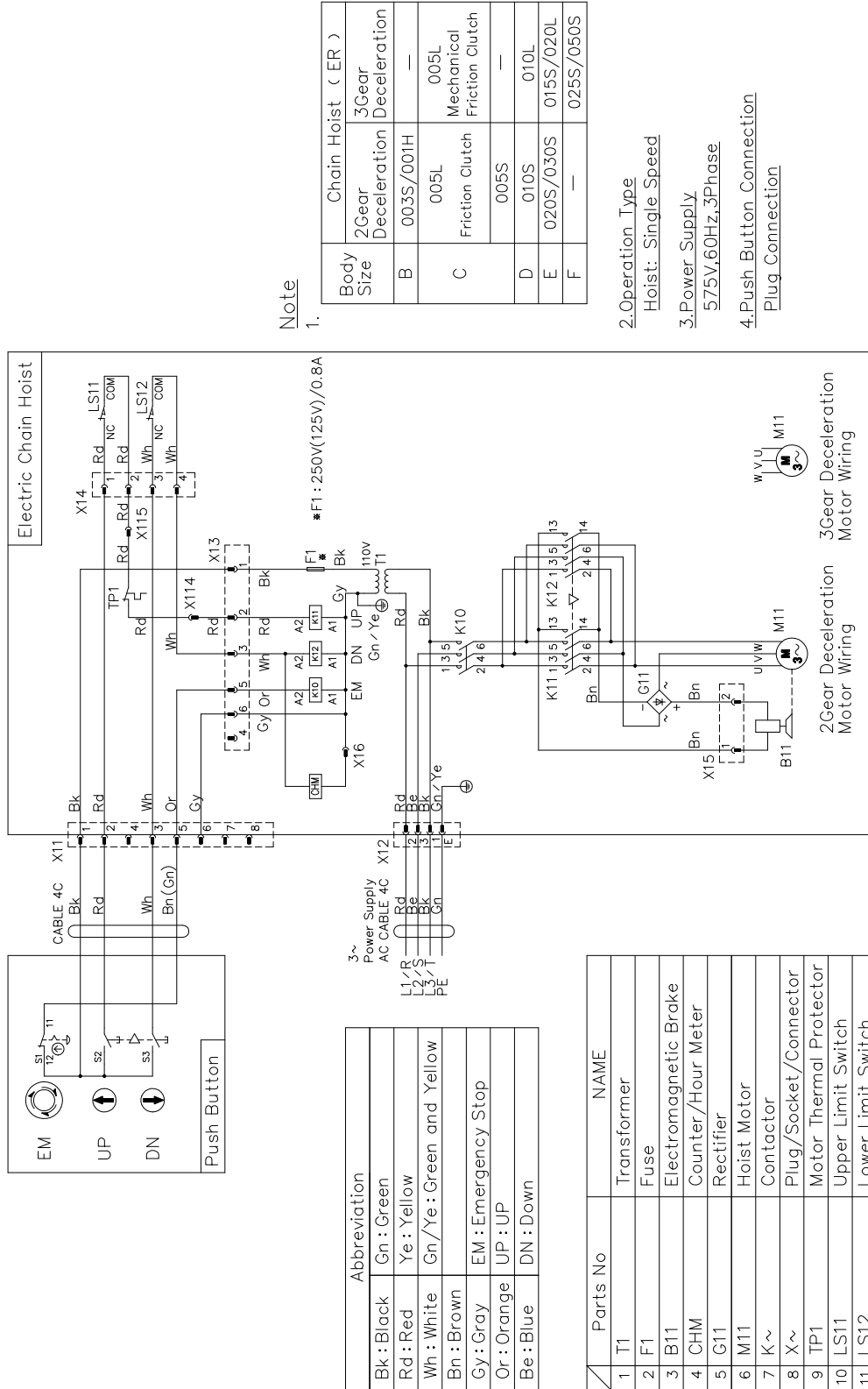

Note

Body Size	Chain Hoist (ER)
B	2Gear Deceleration
C	3Gear Deceleration
D	003S/001H
E	005L
F	005L Mechanical Friction Clutch
	005S
	010S
	020S/030S
	015S/020L
	025S/050S

1. Operation Type
Hoist: Single Speed
2. Power Supply
575V, 60Hz, 3Phase
3. Push Button Connection
Plug Connection

Abbreviation	NAME
Bk : Black	Gn : Green
Rd : Red	Ye : Yellow
Wh : White	Gn/Ye : Green and Yellow
Bn : Brown	
Gy : Gray	EM : Emergency Stop
Or : Orange	UP : UP
Be : Blue	DN : Down

Parts No	NAME
1	T1 Transformer
2	F1 Fuse
3	B11 Electromagnetic Brake
4	CHM Counter/Hour Meter
5	G11 Rectifier
6	M11 Hoist Motor
7	K~ Contactor
8	X~ Plug/Socket/Connector
9	TP1 Motor Thermal Protector
10	LS11 Upper Limit Switch
11	LS12 Lower Limit Switch

220V (Plug Connection)

Abbreviation	
Bk : Black	Gn : Green
Rd : Red	Ye : Yellow
Wh : White	Gn/Ye : Green and Yellow
Bn : Brown	EM : Emergency Stop
Gy : Gray	UP : UP
Or : Orange	DN : Down
Be : Blue	

Note

Body Size	Chain Hoist (ER)
B	2Gear Deceleration 003S/001H
C	3Gear Deceleration 005L Friction Clutch Mechanical Friction Clutch
D	005S
E	010S
F	020S/030S 015S/020L 025S/050S

1. Operation Type
Hoist: Single Speed
2. Power Supply
220V,60Hz,3Phase
3. Push Button Connection
Plug Connection

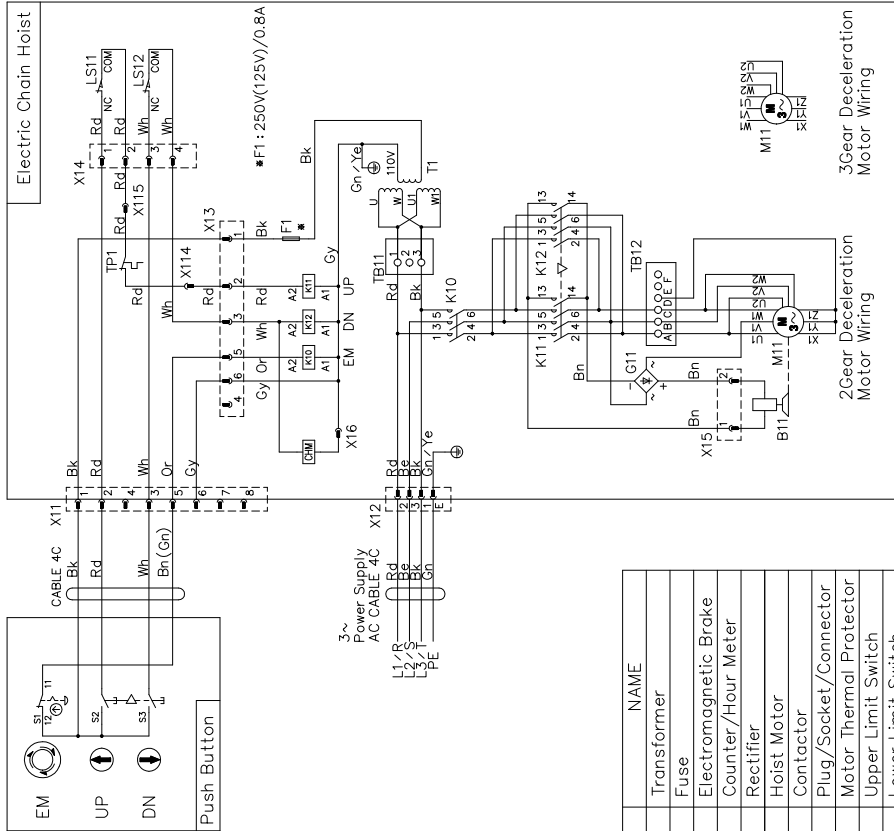

Parts No	NAME
1	T1 Transformer
2	F1 Fuse
3	B11 Electromagnetic Brake
4	CHM Counter/Hour Meter
5	G11 Rectifier
6	M11 Hoist Motor
7	K~ Contactor
8	X~ Plug/Socket/Connector
9	TP1 Motor Thermal Protector
10	LS11 Upper Limit Switch
11	LS12 Lower Limit Switch

440V (Plug Connection)

Abbreviation	
Bk : Black	Gn : Green
Rd : Red	Ye : Yellow
Wh : White	Gn/Ye : Green and Yellow
Bn : Brown	EM : Emergency Stop
Gy : Gray	UP : UP
Or : Orange	DN : Down
Be : Blue	

Note

Body Size	Chain Hoist (ER)
B	2Gear Deceleration
C	3Gear Deceleration
D	005L Friction Clutch
E	005L Mechanical Friction Clutch
F	010L Friction Clutch
	010S Mechanical Friction Clutch
	015S/020L Friction Clutch
	025S/050S Friction Clutch

1. Operation Type
Hoist: Single Speed
2. Power Supply
440V, 60Hz, 3Phase
3. Push Button Connection
Plug Connection

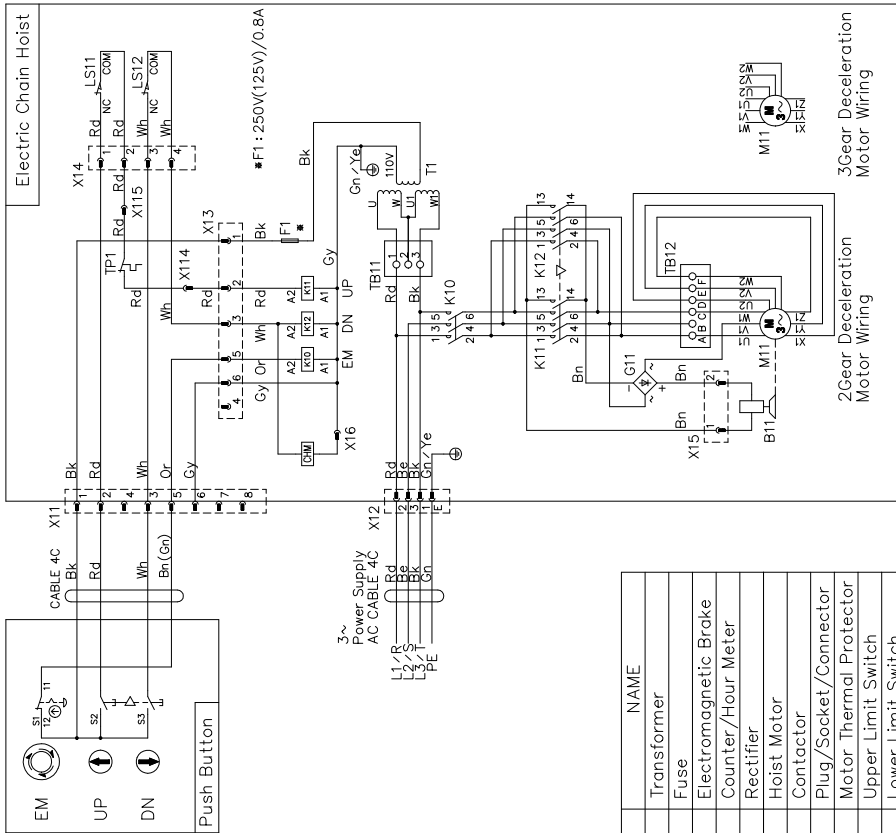

Parts No	NAME
1	T1 Transformer
2	F1 Fuse
3	B11 Electromagnetic Brake
4	CHM Counter/Hour Meter
5	G11 Rectifier
6	M11 Hoist Motor
7	K~ Contactor
8	X~ Plug/Socket/Connector
9	TP1 Motor Thermal Protector
10	LS11 Upper Limit Switch
11	LS12 Lower Limit Switch

Wiring Diagram of Dual Speed ER2/ER2SP/ER2SG 220V (Plug Connection)

Parts No	NAME
1 T1	Transformer
2 F1	Fuse
3 B11	Electromagnetic Brake
4 G11	Rectifier
5 M11	Hoist Motor
6 RV~	Relay
7 CR~	Surge Absorber
8 X~	Plug/Socket/Connector
9 TP1	Motor Thermal Protector
10 LS11	Upper Limit Switch
11 LS12	Lower Limit Switch
12 I/F BRD1	Interface Board
13 INV1	Inverter
14 R1	Resistance

Note

- | Body Size | Chain Hoist (ER) |
|-----------|---|
| B | 2Gear Deceleration
001IH/003IS |
| C | 005IL Mechanical Friction Clutch
005IS |
| D | 010IS |
| E | 020IS/030IS 015IS/020IL |
| F | — 025IS/050IS |

- Operation Type
Hoist: Dual Speed
- Power Supply
220V, 60Hz, 3Phase
- Push Button Connection
Plug Connection

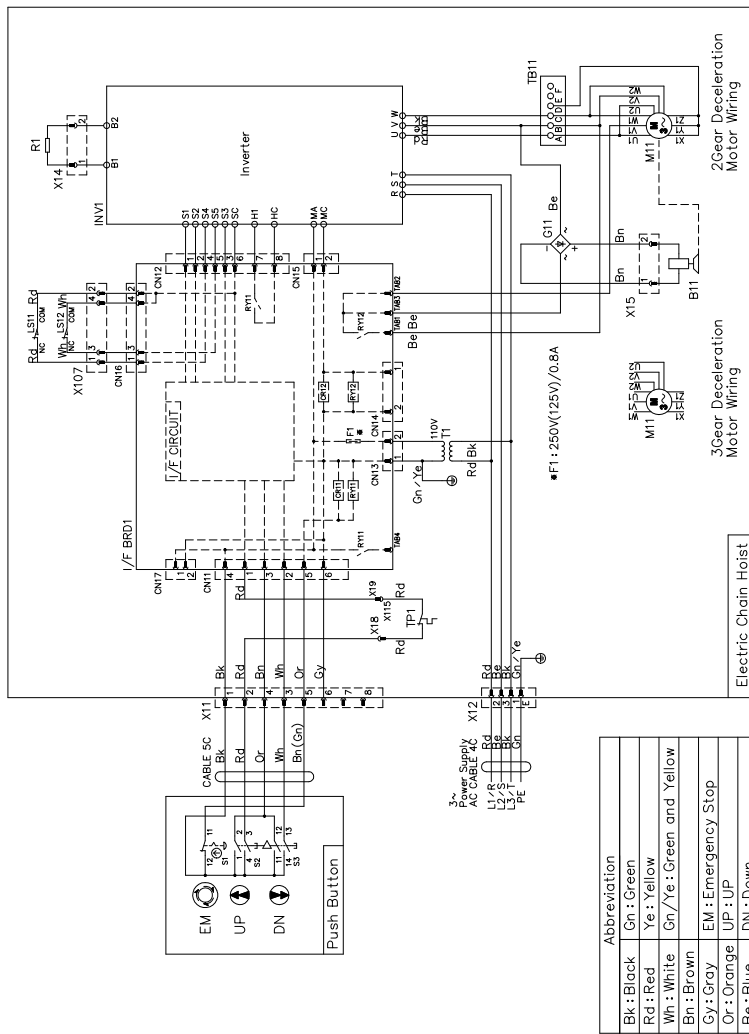

Abbreviation	
Bk	: Black
Gn	: Green
Rd	: Red
Ye	: Yellow
Wh	: White
Gn/Ye	: Green and Yellow
Brn	: Brown
Gy	: Gray
Or	: Orange
EM	: Emergency Stop
UP	: UP
DN	: Down



Technical Material (continued)

440V (Plug Connection)

Parts No	NAME
1	TI Transformer
2	F1 Fuse
3	B11 Electromagnetic Brake
4	G11 Rectifier
5	M11 Hoist Motor
6	RY~ Relay
7	CR~ Surge Absorber
8	X~ Plug/Socket/Connector
9	TP1 Motor Thermal Protector
10	LS11 Upper Limit Switch
11	LS12 Lower Limit Switch
12	I/F BRD1 Interface Board
13	INV1 Inverter
14	RT Resistance

Note

1.

Body Size	Chain Hoist (ER)
B	2Gear Deceleration 001H/003S
C	005IL Mechanical Friction Clutch 005S
D	010IS
E	020IS/030IS
F	025IS/050IS

- 2.Operation Type
Hoist: Dual Speed
- 3.Power Supply
440V,60Hz,3Phase
- 4.Push Button Connection
Plug Connection

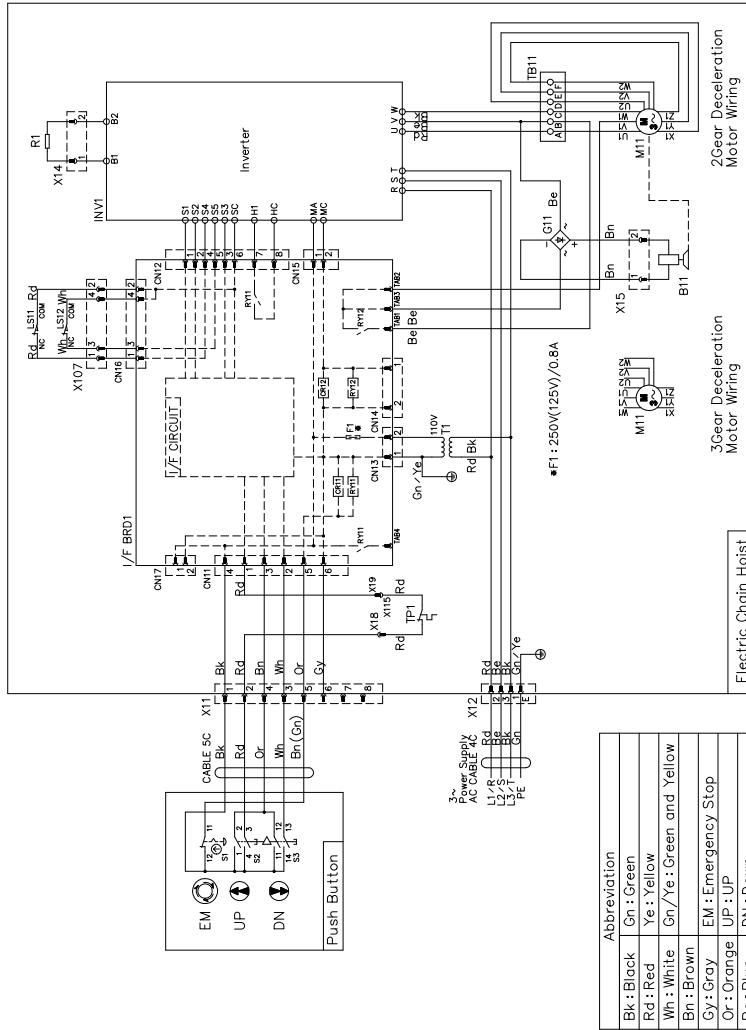

575V (Plug Connection)

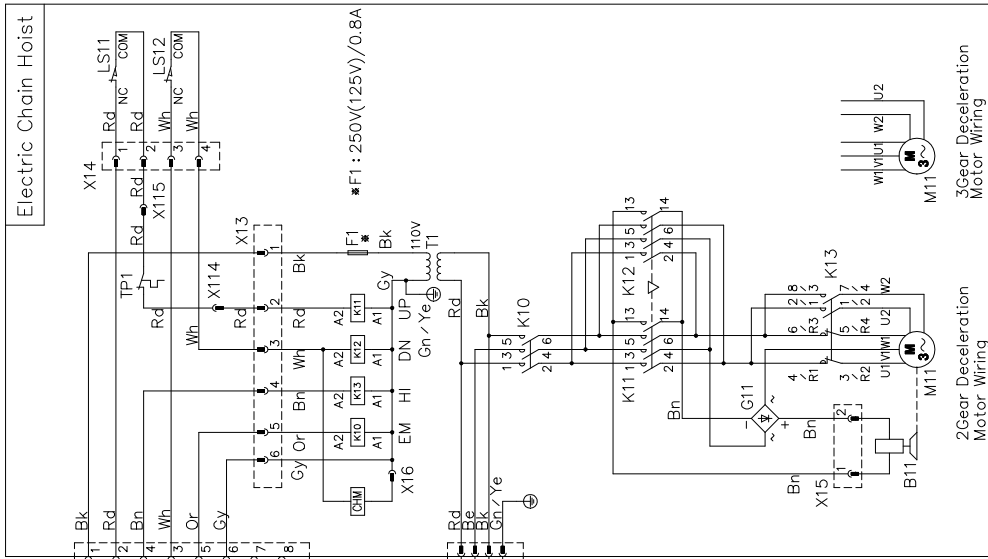

Note

Body Size	Chain Hoist (ER)
B	2Gear Deceleration
C	3Gear Deceleration
D	—
E	—
F	—

1. Operation Type
Hoist: Dual Speed
2. Power Supply
575V, 60Hz, 3Phase
3. Push Button Connection
Plug Connection

Abbreviation	NAME
Bk : Black	Transformer
Gn : Green	Fuse
Rd : Red	Electromagnetic Brake
Wh : White	Counter/Hour Meter
Bn : Brown	Rectifier
Gy : Gray	Hoist Motor
Or : Orange	Contact
Be : Blue	Plug/Socket/Connector
	Motor Thermal Protector
	Upper Limit Switch
	Lower Limit Switch

Parts No	NAME
1	T1
2	F1
3	B11
4	CHM
5	G11
6	M11
7	K~
8	X~
9	TP1
10	LS11
11	LS12

(to be continued)

Technical Material (continued)

Wiring Diagram of Single Speed ER2M 575V (Plug Connection)

Parts No	NAME
1 TT	Transformer
2 F1	Fuse
3 B11	Electromagnetic Brake
4 CHM	Counter/Hour Meter
5 G11	Rectifier
6 M11	Hoist Motor
7 M21	Trolley Motor
8 K~	Contact
9 X~	Plug/Socket/Connector
10 TP~	Motor Thermal Protector
11 LS11	Upper Limit Switch
12 LS12	Lower Limit Switch
13 TB~	Terminal

Abbreviation
Bk : Black
Gn : Green
Rd : Red
Ye : Yellow
Wh : White
Gn/Ye : Green and Yellow
Bn : Brown
Gy : Gray
EM : Emergency Stop
Or : Orange
UP : UP
DN : Down

Note

Body Size	Chain Hoist (ER)
B	2Gear Deceleration
C	3Gear Deceleration
D	003S/001H
E	005L
F	005S
	010S
	020S/030S
	010L
	025S/050S

2.Operation Type
Hoist: Single Speed
Trolley: Single Speed

3.Power Supply
575V,60Hz,3Phase

4.Push Button Connection
Plug Connection

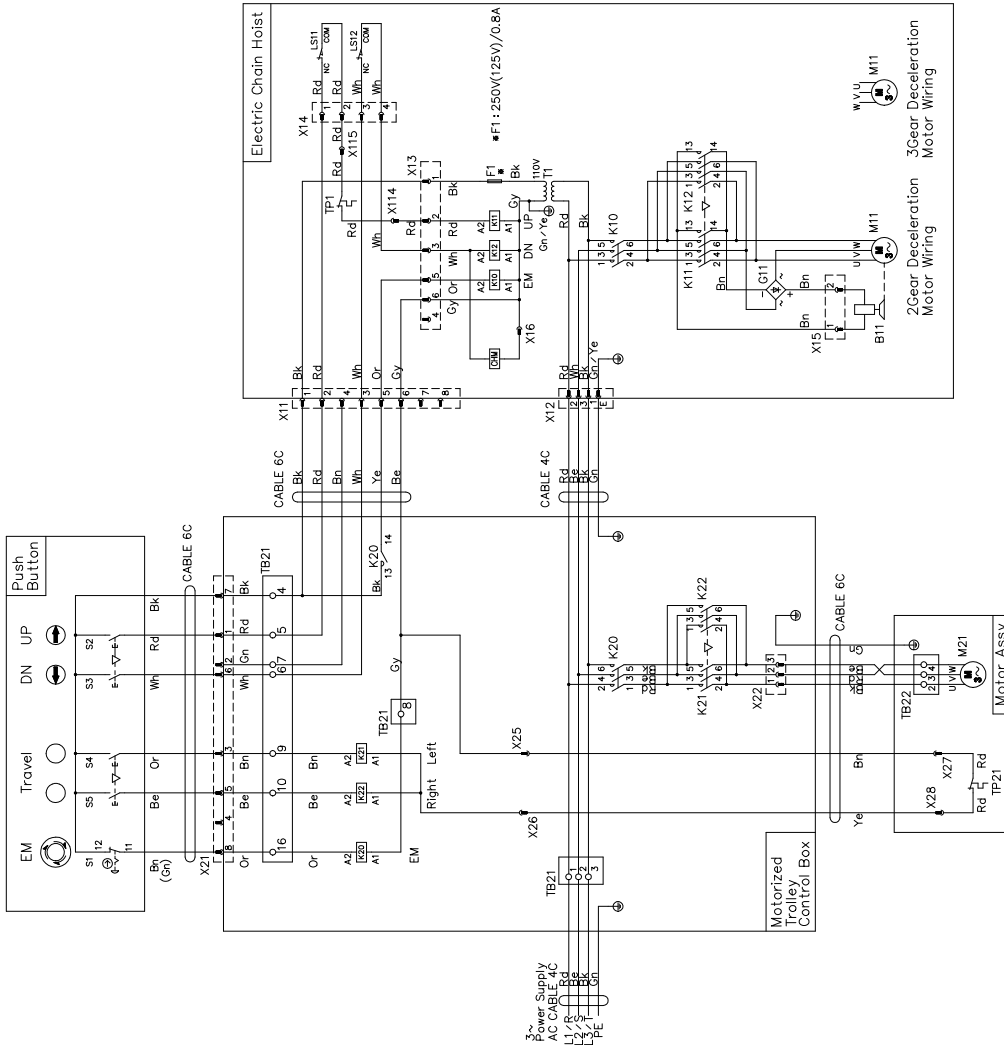

220V (Plug Connection)

Parts No	NAME
1 T1	Transformer
2 F1	Fuse
3 B11	Electromagnetic Brake
4 CHM	Counter/Hour Meter
5 G11	Rectifier
6 M11	Hoist Motor
7 M21	Trolley Motor
8 K~	Contact
9 X~	Plug/Socket/Connector
10 TP~	Motor Thermal Protector
11 LS11	Upper Limit Switch
12 LS12	Lower Limit Switch
13 TB~	Terminal

Abbreviation
Bk : Black
Gn : Green
Rd : Red
Yl : Yellow
Wh : White
Gr/Ye : Green and Yellow
Bn : Brown
Gy : Gray
EM : Emergency Stop
UP : UP
DN : Down

Note

Body Size	Chain Hoist (ER)
B	2Gear Deceleration
C	3Gear Deceleration
D	005L Friction clutch Mechanical Friction Clutch
E	005S —
F	010S —
	020S/030S 015S/020L 025S/050S

- 2.Operation Type
Hoist: Single Speed
Trolley: Single Speed
- 3.Power Supply
220V,60Hz,3Phase
- 4.Push Button Connection
Plug Connection

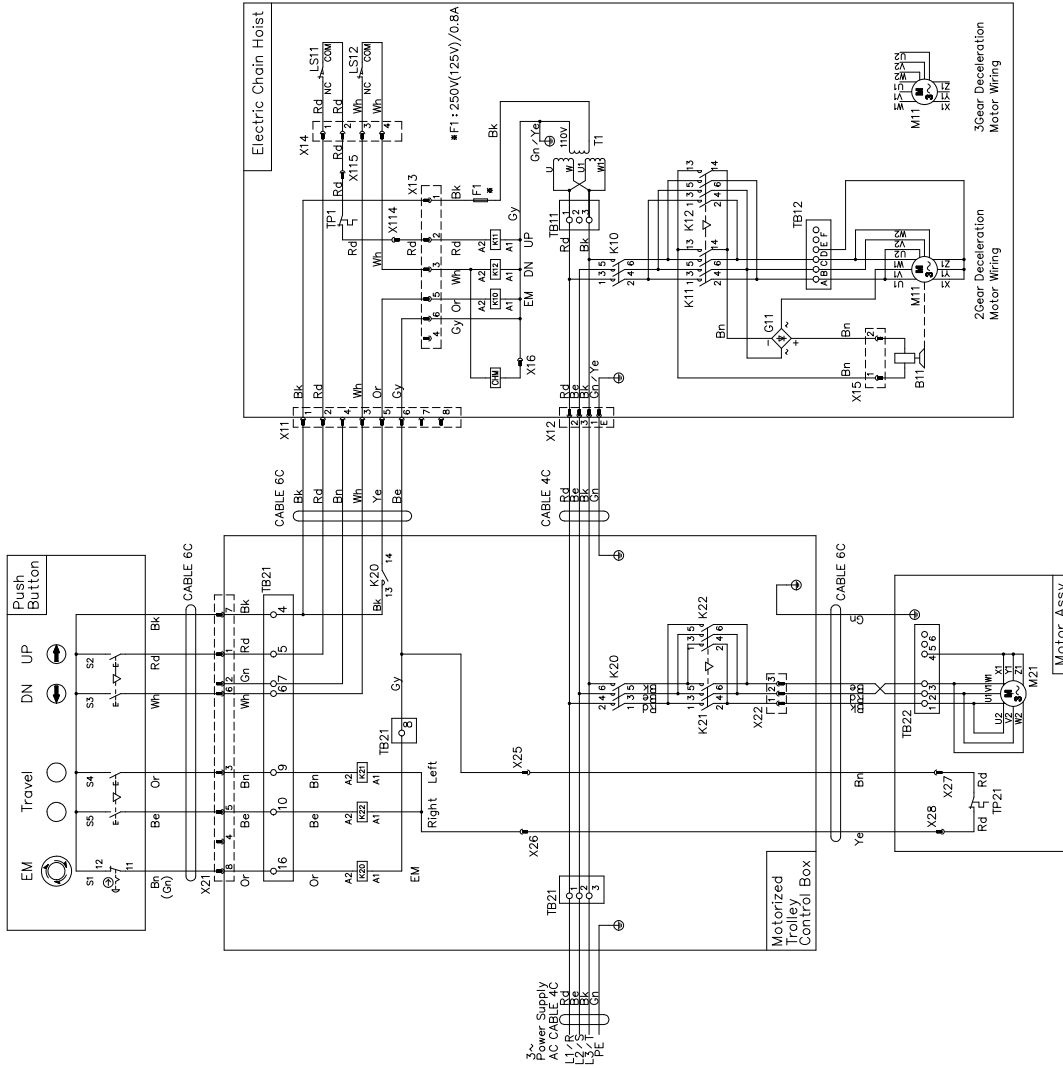

(to be continued)

Technical Material (continued)

440V (Plug Connection)

Parts No	NAME
1 T1	Transformer
2 F1	Fuse
3 B11	Electromagnetic Brake
4 CHM	Counter/Hour Meter
5 C11	Rectifier
6 M11	Hoist Motor
7 M21	Trolley Motor
8 K~	Contact
9 X~	Plug/Socket/Connector
10 TP~	Motor Thermal Protector
11 LS11	Upper Limit Switch
12 LS12	Lower Limit Switch
13 TB~	Terminal

Abbreviation
Bk : Black
Gn : Green
Rd : Red
Ye : Yellow
Wh : White
Gn/Ye : Green and Yellow
Bn : Brown
Gy : Gray
EM : Emergency Stop
UP : Up
DN : Down

Note

Body Size	Chain Hoist (ER)
B	2Gear Deceleration 003S/001H
C	3Gear Deceleration 005L Mechanical Friction Clutch
D	005S
E	010S 020S/030S
F	010L 015S/020L 025S/050S

1. Operation Type
Hoist: Single Speed
Trolley: Single Speed
2. Power Supply
440V, 60Hz, 3Phase
3. Push Button Connection
4. Plug Connection

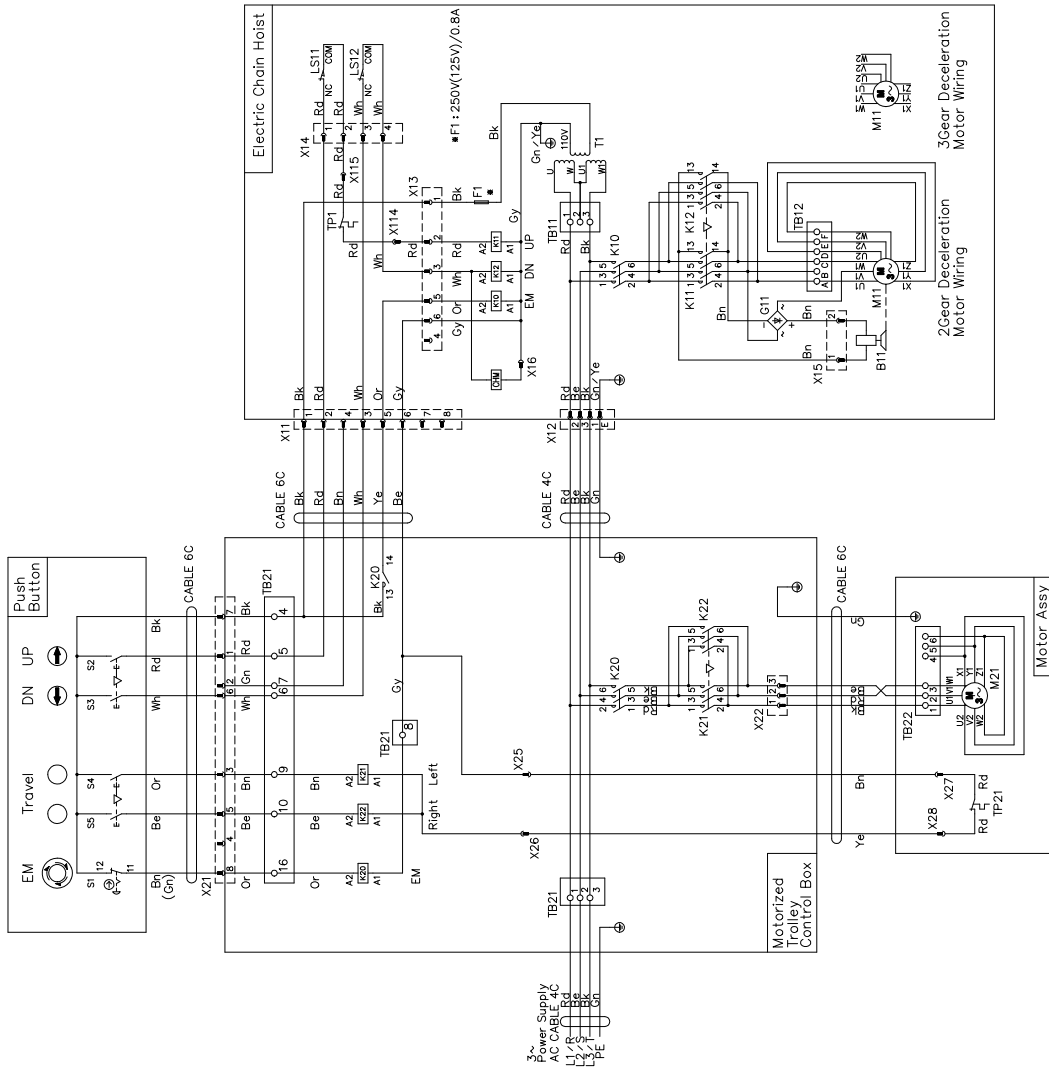

Wiring Diagram of Dual Speed ER2M

220V (Plug Connection)

Parts No	NAME
1	T1 Transformer
2	F1 Fuse
3	B11 Electromagnetic Brake
4	G11 Rectifier
5	M11 Hoist Motor
6	M21 Trolley Motor
7	RY~ Relay
8	CR~ Surge Absorber
9	X~ Plug/Socket/Connector
10	TP~ Motor Thermal Protector
11	LS11 Upper Limit Switch
12	LS12 Lower Limit Switch
13	I/F BRD~ Interface Board
14	TB~ Terminal
15	INV~ Inverter
16	R~ Resistance

Abbreviation	Color
Bk	Black
On	Green
Rd	Red
Wh	White
On/Ye	Green and Yellow
Bn	Brown
Gy	Gray
Or	Orange
Be	Blue
DN	Down
UP	Up

Note

Body Size	Chain Hoist (ER)
B	001H/003S
C	005L 005LL Friction Cutch Friction Cutch
D	010S
E	020S/030S
F	015S/020LL 025S/050S

1. Operation Type
Hoist: Dual Speed
Trolley: Dual Speed
2. Power Supply
220V, 60Hz, 3Phase
3. Push Button Connection
Plug Connection

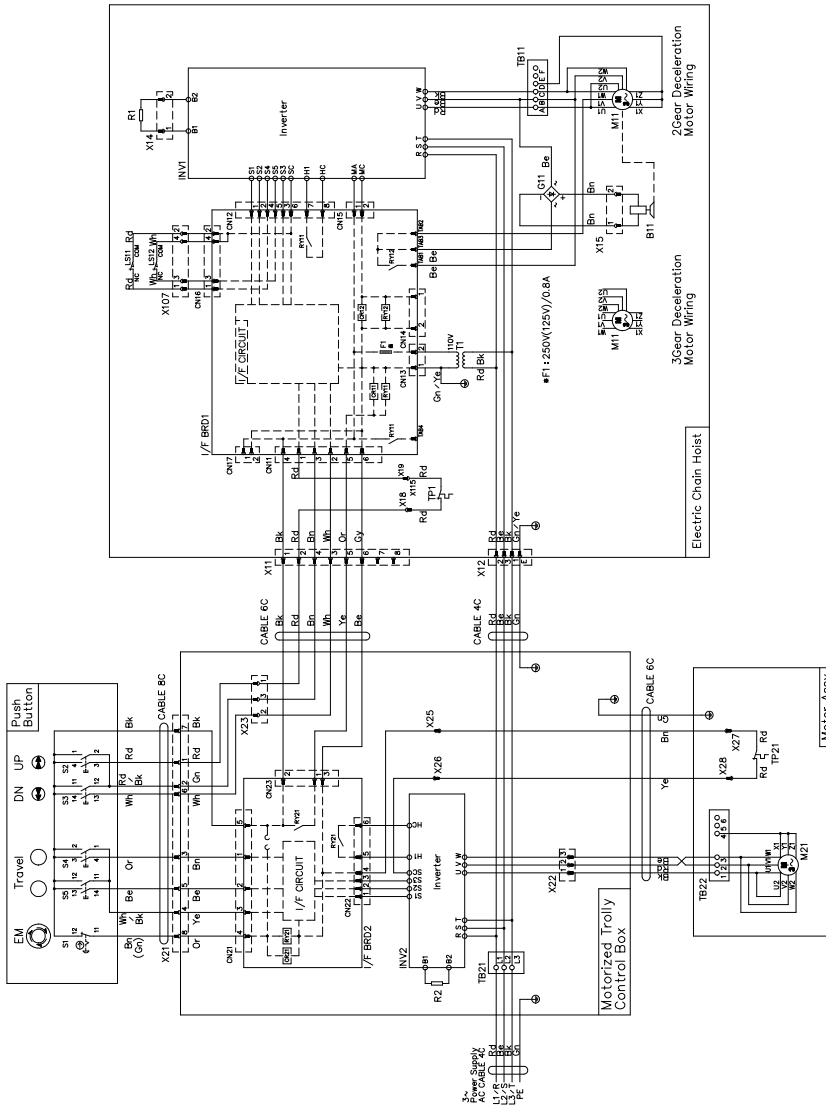

Technical Material (continued)

440V (Plug Connection)

Ports No	NAME
1	TI
2	FT
3	B11
4	G11
5	M1
6	M21
7	R1~
8	CR~
9	Y~
10	TP~
11	LS11
12	LS12
13	1/F BRD~
14	TB~
15	INV~
16	R~

Abbreviation	NAME
Bk: Black	On: Green
Rd: Red	Ye: Yellow
Wh: White	On/Ye: Green and Yellow
Br: Brown	
Gy: Gray	EM: Emergency Stop
Or: Orange	UP: UP
Bl: Blue	DN: Down

NOTE

Body Size	Chain Hoist (ER)
2Gear Deceleration	3Gear Deceleration
B 001H/003S	—
C 005L	005L Mechanical Friction Clutch
D 005S	—
E 020S/030S	015S/020L
F —	025S/050S

1. Operation Type
Hoist: Dual Speed
Trolley: Dual Speed
2. Power Supply
440V/60Hz, 3Phase
3. Plug Connection

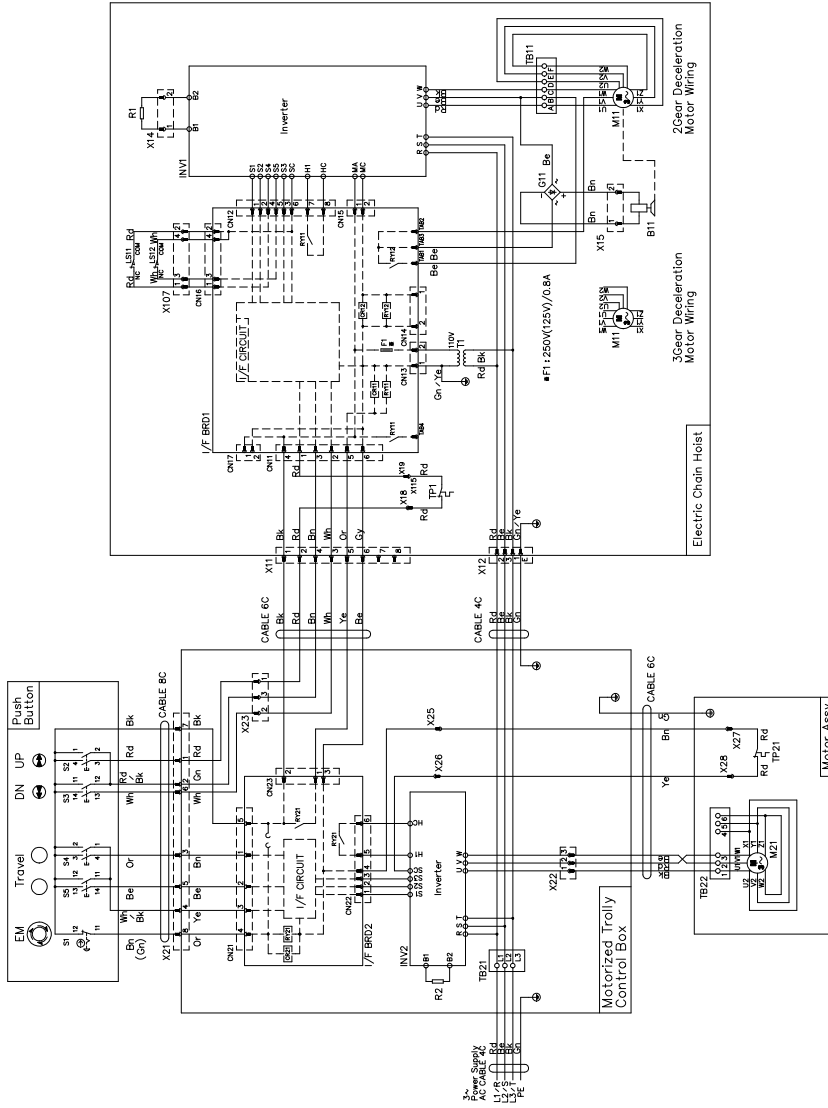

575V (Plug Connection)

Parts No	NAME
1	Transformer
2	F1
3	B11
4	CHM
5	GT1
6	M11
7	IMZ1
8	K~
9	X~
10	TP~
11	LS11
12	LS12
13	TB~

Abbreviation
Gn: Green
Rd: Red
Ye: Yellow
Wh: White
Gn/Ye: Green and Yellow
Bn: Brown
EM: Emergency Stop
Gy: Gray
UP: UP
Or: Orange
DN: Down
Be: Blue
HI: High Speed

Body Size	Chain Hoist (ER)
B	2Gear Deceleration
C	3Gear Deceleration
D	003SD/001HD
E	005SD/005LD
F	010SD/010LD
	015SD
	020LD/020SD
	030SD
	025SD/050SD

1. Note
2. Operation Type
3. Power Supply
4. Push Button Connection

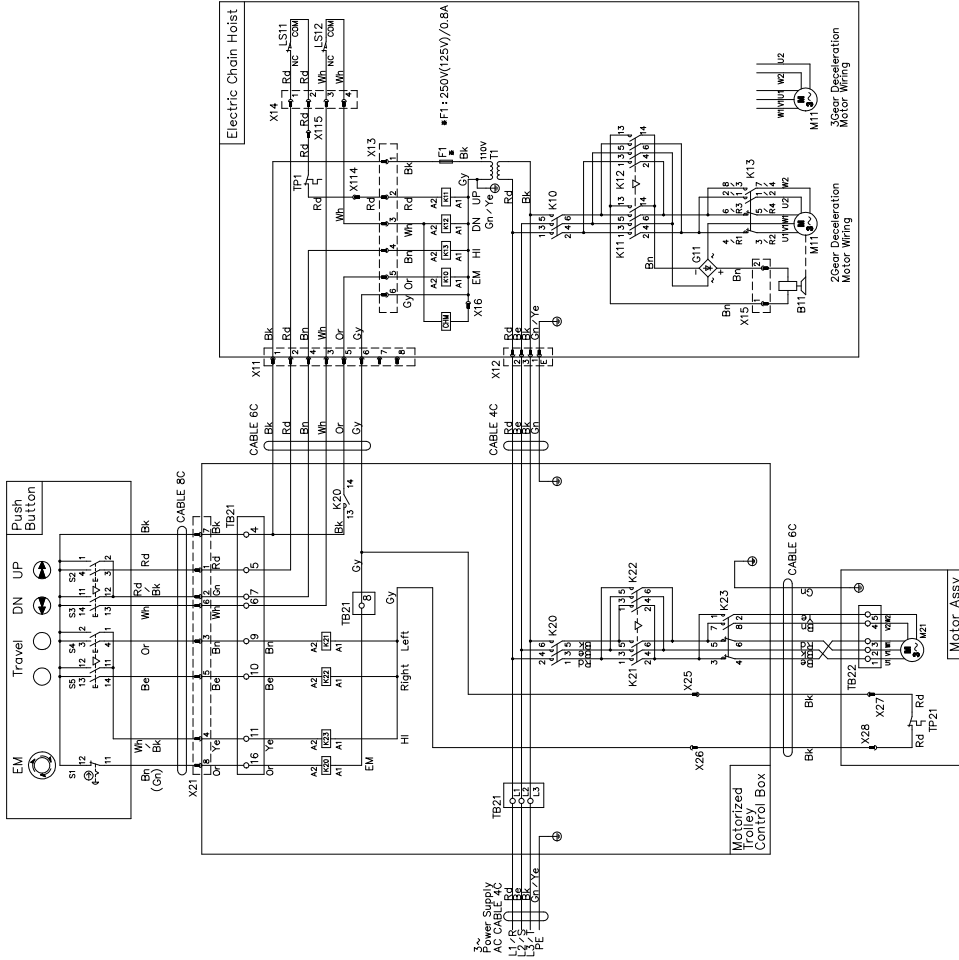

Daily Inspection Check Sheet

Code	Capacity	Lot No.	Your CTRL No.	Installation date	Location	Inspection Certification valid thru
Electric Chain Hoist	ER2					
Motorized Trolley	MR2					
Geared Trolley	TS2 (TSG)					
Plain Trolley	TS2 (TSP)					

Electric Chain Hoist

■ Check result : ○ Good, △ To be replaced (adjusted) next inspection, × Bad, Needs replacement (adjustment)

Category	Check item	Check method	Criteria	Inspection date/result					
				/	/	/	/	/	/
Appearance	Indication of nameplates and labels	Check visually	To have no peeled off. To be legible clearly.						
	Deformation and damage of each part of body	Check visually	To have no apparent deformation or corrosion						
	Bolts, nut, split pins	Check visually	To have no loosened bolts, nuts, and split pins that can be seen from exterior. To have no come-off.						
Load Chain	Elongation of pitch	Check visually	To have no apparent elongation						
	Abrasion of wire diameter	Check visually	To have no apparent abrasion						
	Deformation, flaw, entanglement	Check visually	To have no apparent deformation, harmful flaw and entanglement						
	Rust, corrosion	Check visually	To have no apparent rust and corrosion						
	Twist	Check visually	To have no twisting due to capsized Bottom Hook of double type						
	Oiling	Check visually	To be oiled adequately						
	Mark	Check visually	To have no error in mark and marked pitch						
Top Hook, Bottom Hook	Stretched opening	Check visually	To have no stretched opening						
	Abrasion	Check visually	To have no apparent abrasion						
	Deformation, flaw, corrosion	Check visually	To have no apparent deformation, harmful flaw and corrosion						
	Hook Latch motion	Check visually/inspection by operation	To open/close smoothly						
	Hook motion (swivel)	Check visually/inspection by operation	To have no apparent gap between Hook and Bottom Yoke						
	Idle Sheave motion	Check visually/inspection by operation	Load Chain to move smoothly						
	Bottom Yoke	Check visually	To have no loosened bolt and nut						
Body peripheral part	Chain spring	Check visually	No apparent shrinkage or compression						
	Cushion rubber	Check visually	<ul style="list-style-type: none"> No apparent shrinkage or compression No peel off, crack of deformation of rubber 						
Push Button Switch	Switch body	Check visually	<ul style="list-style-type: none"> To have no deformation, damage and loosened screw Indication to be legible clearly 						
Function/performance	Operational check	Press the push buttons to check the operation	<ul style="list-style-type: none"> Load Chain to be wound smoothly Electric Chain Hoist operates in the same direction as that of the push button operation Motor to stop immediately when stopping the operation All operations to stop when Emergency Stop is pressed Electric Chain Hoist not to operate when pressing the push button while Emergency Stop is pressed Electric Chain Hoist to operate normally when canceling Emergency Stop 						
	Brake	Lifting/lowering operation with no load	Brake to operate securely and Bottom Hook to stop immediately (Guideline: Travel of the load chain is within 2 to 3 links.)						
	Friction Clutch with Mechanical Brake	Lifting/lowering operation with no load	To sound clicking noise of pawl when lifting						
	Limit switch	Lifting/lowering operation with no load	Motor to stop automatically when operating the electric chain hoist to upper/lower limit						
	Abnormal noise	Lifting/lowering operation with no load	To have no strange sound or vibration						

Executed by	Inspector								
Checked by	Maintenance Engineer								

Motorized Trolley

■ Check result : ○ Good, △ To be replaced (adjusted) next inspection, × Bad, Needs replacement (adjustment)

Category	Check item	Check method	Criteria	Inspection date/result					
				/	/	/	/	/	/
Appearance	Indication of nameplates and labels	Check visually	To have no peeled off. To be legible clearly.						
	Deformation and damage of each part	Check visually	To have no apparent deformation and corrosion Frame to have no apparent deformation						
	Bolts, nut, split pins	Check visually or inspection with tools	To have no loosened bolts, nuts, and split pins that can be seen from exterior. To have no come-off.						
Function/performance	Operational check	Traveling operation with no load	<ul style="list-style-type: none"> To travel smoothly. To have no serpentine motion and vibration. Motorized Trolley operates in the same direction as that of the push button operation Motor to stop immediately when stopping the operation All operations to stop when Emergency Stop is pressed Motorized Trolley not to operate when pressing the push button while Emergency Stop is pressed Motorized Trolley to operate normally when canceling Emergency Stop 						
	Brake	Traveling operation with no load	When stopping the operation, brake to operate securely and motor to stop immediately.						

Executed by	Inspector						
Checked by	Maintenance Engineer						

Manual Trolley

■ Check result : ○ Good, △ To be replaced (adjusted) next inspection, × Bad, Needs replacement (adjustment)

Category	Check item	Check method	Criteria	Inspection date/result					
				/	/	/	/	/	/
Appearance	Indication of nameplates and labels	Check visually	To have no peeled off. To be legible clearly.						
	Deformation and damage of each part	Check visually	<ul style="list-style-type: none"> To have no apparent deformation and corrosion Frame to have no apparent deformation 						
	Bolts, nut, split pins	Check visually	To have no loosened bolts, nuts, and split pins that can be seen from exterior. To have no come-off.						
Function/performance	Operational check	Traveling operation with no load	<ul style="list-style-type: none"> To travel smoothly. To have no serpentine motion and vibration. 						

Executed by	Inspector						
Checked by	Maintenance Engineer						

Monthly Inspection Check Sheet

Code	Capacity	Lot No.	Your CTRL No.	Installation date	Location	Inspection Certification valid thru
Electric Chain Hoist	ER2					
Motorized Trolley	MR2					
Geared Trolley	TS2 (TSG)					
Plain Trolley	TS2 (TSP)					

■ Electric Chain Hoist

■ Check result : ○ Good, △ To be replaced (adjusted) next inspection, × Bad, Needs replacement (adjustment)

Category	Check item	Check method	Criteria	Inspection date/result					
				/	/	/	/	/	/
Preceding inspection	Daily inspection	Check the execution	When performing monthly inspection, also perform the daily inspection.						
Load Chain	Elongation of pitch	Pitch measurement	Sum of pitches for 5 links must not exceed the limit value.						
	Abrasion of wire diameter	Diameter measurement	Not to exceed the limit value						
Top Hook, Bottom Hook	Stretched opening	Measurement	Interval between embossed marks not to exceed the limit value						
	Abrasion	Measurement	To have no abrasion exceeding the limit value (5 %)						
	Deformation, flaw, corrosion	Check visually	<ul style="list-style-type: none"> • To have no bending and twist • To have no attached foreign matter such as sputter 						
Body peripheral part	Chain container	Check visually	<ul style="list-style-type: none"> • To be mounted securely • To have no breakage, deformation and foreign matter • Lift must be shorter than the length of the permissible capacity of the chain container 						
Push Button Switch	Switch body	Check visually/ inspection by operation	<ul style="list-style-type: none"> • Operation buttons to move smoothly • Emergency Stop button to be enabled to operate and cancel 						
	Push Button Switch cord	Check visually	<ul style="list-style-type: none"> • To be tied securely • Protection wire to prevent external force to be applied on the cord when being pulled • To have no damage 						
Power feeding	Power cable	Check visually	<ul style="list-style-type: none"> • To have slack • To have no damage • To be connected securely 						
	Cable hanger	Check visually	<ul style="list-style-type: none"> • To have no damage • To move with a small force • To be mounted at equal spacing 						
	Messenger wire	Check visually	<ul style="list-style-type: none"> • To have no slack 						
Function/performance	Abnormal noise	Lifting/lowering operation with no load	<ul style="list-style-type: none"> • To sound no irregular rotating noise. • To sound no howling of motor and scraping sound of the Brake. • To sound no abnormal noise. • To sound no popping sound from the Load Chain. 						

Executed by	Inspector					
Checked by	Maintenance Engineer					

■ Motorized Trolley

■ Check result : ○ Good, △ To be replaced (adjusted) next inspection, × Bad, Needs replacement (adjustment)

Category	Check item	Check method	Criteria	Inspection date/result					
				/	/	/	/	/	/
Preceding inspection	Daily inspection	Check the execution	When performing monthly inspection, also perform the daily inspection.						
Travel Rail (Recommendation)	Appearance	Check visually	To have no apparent deformation and damage						
Refer to check table of electric chain hoist ER2 for electrical parts, push button switch, power feeding and electrical characteristics.									
Connection Status	connection parts	Swing the chain to rock the trolley	<ul style="list-style-type: none"> The electric chain block does not tilt significantly. No looseness at the joints and no rattling between parts. 						

Executed by	Inspector						
Checked by	Maintenance Engineer						

■ Manual Trolley

■ Check result : ○ Good, △ To be replaced (adjusted) next inspection, × Bad, Needs replacement (adjustment)

Category	Check item	Check method	Criteria	Inspection date/result					
				/	/	/	/	/	/
Preceding inspection	Daily inspection	Check the execution	When performing monthly inspection, also perform the daily inspection.						
Travel Rail (Recommendation)	Appearance	Check visually	To have no apparent deformation and damage						
Connection Status	connection parts	Swing the chain to rock the trolley	<ul style="list-style-type: none"> The electric chain block lightly rocks. No looseness at the joints and no rattling between parts. 						

Executed by	Inspector						
Checked by	Maintenance Engineer						

Annual Inspection Check Sheet

Code	Capacity	Lot No.	Your CTRL No.	Installation date	Location	Inspection Certification valid thru
Electric Chain Hoist	ER2					
Motorized Trolley	MR2					
Geared Trolley	TS2 (TSG)					
Plain Trolley	TS2 (TSP)					

Electric Chain Hoist (1/2)

■ Check result : ○ Good, △ To be replaced (adjusted) next inspection, × Bad, Needs replacement (adjustment)

Category	Check item	Check method	Criteria	Inspection date/result					
				/	/	/	/	/	/
Preceding inspection	Daily inspection	Check the execution	When performing annual inspection, also perform the daily inspection.						
	Monthly inspection	Check the execution	When performing annual inspection, also perform the monthly inspection.						
Check of the Operation History		Check the number of starts and operating hours	Perform maintenance by referring to the number of starts and operating hours						
Body peripheral part	Chain guide A	Check visually	<ul style="list-style-type: none"> To have no apparent abrasion and damage To have no flaw due to hitting by Load Chain 						
	Chain spring	Check visually/ inspection by measurement	<ul style="list-style-type: none"> To have no apparent permanent setting (deformation) Length of the chain spring to be longer than the criteria 						
	Stopper	Check visually	Stopper must be mounted securely at the third link from the load chain end at no load side						
	Limit lever	Check visually/ inspection by operation	<ul style="list-style-type: none"> To have no deformation, damage and abrasion To move smoothly To be clean 						
	Chain pin	Check visually/ inspection by measurement	<ul style="list-style-type: none"> To have no apparent deformation and flaw Not to exceed the limit value 						
	Connection Yoke	Check visually/ inspection by measurement	<ul style="list-style-type: none"> To have no apparent deformation, abrasion and damage The difference between the hole diameter in vertical and lateral to be within 0.5 mm 						
	Shaft retainer clip	Check visually	<ul style="list-style-type: none"> To have no deformation, damage and abrasion To be mounted securely without looseness 						
Gear box	Appearance	Check visually	<ul style="list-style-type: none"> To have no harmful deformation, crack, and remarkable corrosion. To have no crack at the connecting part between the body and the hook or suspender. 						
	Oil Leakage	Check visually	<ul style="list-style-type: none"> To have no leakage of oil from the following parts. Joint between body and gear case. Oil plugs and oil check hole. 						
	Oil amount and stain	Check the oil level from the oil check hole.	<ul style="list-style-type: none"> Gear oil is filled enough close to the oil check hole. Gear oil has viscosity and not stained. 						
Electromagnetic brake	Appearance	Check visually	<ul style="list-style-type: none"> To have no loosened bolts and screws To have no flaw and damage 						
	Gap	Measurement	The gap not to exceed the limit value						
	Hub and joint	Check visually	<ul style="list-style-type: none"> To have no deformation and abrasion Hub spring not to come off 						
	V ring	Check visually	To have no deformation and crack						

■ Electric Chain Hoist (2/2)

■ Check result : ○ Good, △ To be replaced (adjusted) next inspection, × Bad, Needs replacement (adjustment)

Category	Check item	Check method	Criteria	Inspection date/result					
				/	/	/	/	/	/
Electrical parts	Electrical parts	Check visually	<ul style="list-style-type: none"> To have no damaged or burnt part To be mounted securely Number of start no to exceed the guidelines for replacement 						
	Wiring	Check visually	<ul style="list-style-type: none"> Wiring to be fixed to electrical parts securely Connector to be inserted securely To have no damaged or burnt part 						
	Intrusion or attachment of foreign matter	Check visually	<ul style="list-style-type: none"> To have no water drop or foreign matter such as dust inside 						
	VFD	Check the CH Meter (check of service life)	<ul style="list-style-type: none"> Electrolytic capacitors 3000 hours (depending on the operating conditions) Refer to "VFD Manual" for other items. 						
Electric characteristics	Source voltage	Measurement	To be supplied power within rated voltage $\pm 10\%$						
	Insulation resistance	Measurement	Insulation resistance to be higher than 5 M Ω						
	Grounding resistance	Measurement	To be grounded with grounding resistance 100 Ω or less						
After replacing the load support member and brake except the chain, check the following with the rated load applied to the electric chain hoist.									
Function and Performance	Operational check	Operate with the rated load.	Refer to the criteria for the same item in the daily inspection section. (See P32)						
	Brake	Operate with the rated load.	When stopping the operation, the Brake must be applied immediately and the motor must stop. Up/Down: Stop distance must be 1 % or less of the traveling distance for one minute.						

Executed by	Inspector								
Checked by	Maintenance Engineer								

Motorized Trolley

■ Check result : ○ Good, △ To be replaced (adjusted) next inspection, × Bad, Needs replacement (adjustment)

Category	Check item	Check method	Criteria	Inspection date/result					
				/	/	/	/	/	/
Preceding inspection	Daily inspection	Check the execution	When performing annual inspection, also perform the daily inspection.						
	Monthly inspection	Check the execution	When performing annual inspection, also perform the monthly inspection.						
Brake	Appearance	Check visually	<ul style="list-style-type: none"> To have no deformation, flaw and damage on the brake drum and motor cover To have no deformation, flaw and damage on brake spring 						
	Brake Pad	Measurement	Abrasion to be less than limit value						
Body component	Wheel	Check visually/ inspection by measurement	<ul style="list-style-type: none"> To have no apparent deformation and damage Abrasion of outer diameter to be less than limit value 						
	Side roller	Check visually/ inspection by measurement	<ul style="list-style-type: none"> To have no apparent deformation and damage Abrasion of outer diameter to be less than limit value 						
	Suspension shaft	Check visually	<ul style="list-style-type: none"> To have no apparent deformation and damage 						
	Suspender	Check visually	<ul style="list-style-type: none"> To have no apparent deformation and damage 						
	Gear frame packing	Check visually	<ul style="list-style-type: none"> To have no damage, breakage and grease leakage. 						
Lubrication	Gearing part of the wheel and drive gear	Check visually	<ul style="list-style-type: none"> Appropriate amount of grease is adhered. 						
Travel Rail (Recommendation)	Rail surface	Check visually	<ul style="list-style-type: none"> To have no attachment of paint, oil and foreign matter To have no dust and powder due to abrasion 						
	Deformation, abrasion	Check visually/ inspection by measurement	<ul style="list-style-type: none"> To have no deformation of beam flange such as twist and shear drop To have no exceeding abrasion of rail surface 						
	Rail fixing bolt	Check visually	To be mounted securely without looseness and come-off						
	Stopper	Check visually	To be mounted securely without looseness and come-off at the rail end						
Relay cable	Appearance	Check visually	To be connected securely without deformation and damage						
Refer to check table of electric chain hoist ER2 for electrical parts, push button switch, power feeding and electrical characteristics.									
After replacing the load support member and brake, check the following with the rated load applied to the trolley.									
Function and Performance	Operational check	Operate with the rated load.	Refer to the criteria for the same item in the daily inspection section. (See P34)						
	Brake	Operate with the rated load.	<ul style="list-style-type: none"> When stopping the operation, the Brake must be applied immediately and the motor must stop. Traveling : Stop distance must be 10 % or less of the traveling distance for one minute. (Without swinging of the load. Except the case when the load is swinging.) 						
	Abnormal noise	Operate with the rated load.	<ul style="list-style-type: none"> To have no irregular rotating noise. To sound no howling of motor and scraping sound of the Brake. 						
Executed by	Inspector								
Checked by	Maintenance Engineer								

Manual Trolley

■ Check result : ○ Good, △ To be replaced (adjusted) next inspection, × Bad, Needs replacement (adjustment)

Category	Check item	Check method	Criteria	Inspection date/result					
				/	/	/	/	/	/
Preceding inspection	Daily inspection	Check the execution	When performing annual inspection, also perform the daily inspection.						
	Monthly inspection	Check the execution	When performing annual inspection, also perform the monthly inspection.						
Body component	Wheel	Check visually/ inspection by measurement	<ul style="list-style-type: none"> To have no apparent deformation and damage Abrasion of outer diameter to be less than limit value 						
	Suspension shaft	Check visually	<ul style="list-style-type: none"> To have no apparent deformation and damage Abrasion of outer diameter to be less than limit value 						
	Suspender	Check visually	<ul style="list-style-type: none"> To have no apparent deformation and damage Abrasion of outer diameter to be less than limit value 						
Lubrication	Gearing part of the wheel and drive gear	Check visually	<ul style="list-style-type: none"> Appropriate amount of grease is adhered. 						
Travel rail (Recommendation)	Rail surface	Check visually	<ul style="list-style-type: none"> To have no attachment of paint, oil and foreign matter To have no dust and powder due to abrasion 						
	Deformation, abrasion	Check visually/ inspection by measurement	<ul style="list-style-type: none"> To have no deformation of beam flange such as twist and shear drop To have no exceeding abrasion of rail surface 						
	Rail fixing bolt	Check visually	To be mounted securely without looseness and come-off						
	Stopper	Check visually	To be mounted securely without looseness and come-off at the rail end						
After replacing the load support member, check the following with the rated load applied to the trolley.									
Function and Performance	Operational check	Operate with the rated load.	Refer to the criteria for the same item in the daily inspection section. (See P35)						
	Abnormal noise	Operate with the rated load.	To have no irregular rotating noise.						
Executed by	Inspector								
Checked by	Maintenance Engineer								

WARRANTY

KITO Corporation (“KITO”) extends the following warranty to the original purchaser (“Purchaser”) of new products manufactured by KITO (KITO’s Products).

- 1) KITO warrants that KITO's Products, when shipped, shall be free from defects in workmanship and/or materials under normal use and service and KITO shall, at the election of KITO, repair or replace free of charge any parts or items which are proven to have said defects, provided that all claims for defects under this warranty shall be made in writing immediately upon discovery and, if there is anything within **a warranty period stated by your dealer from whom you purchased the products** from the date of purchase of KITO's Products by Purchaser and provided, further, that defective parts or items shall be kept for examination by KITO or its authorized agents or returned to KITO's factory or authorized service center upon request by KITO.
- 2) KITO does not warrant components of products provided by other manufacturers. However to the extent possible, KITO will assign to Purchaser applicable warranties of such other manufacturers.
- 3) Except for the repair or replacement mentioned in (1) above which is KITO's sole liability and purchaser’s exclusive remedy under this warranty, KITO shall not be responsible for any other claims arising out of the purchase and use of KITO’s Products, regardless of whether Purchaser’s claims are based on breach of contract, tort or other theories, including claims for any damages whether direct, incidental or consequential.
- 4) This warranty is conditional upon the installation, maintenance and use of KITO’s Products pursuant to the product manuals prepared in accordance with content instructions by KITO. This warranty shall not apply to KITO’s Products which have been subject to negligence, misuse, abuse, misapplication or any improper use or combination or improper fittings, alignment or maintenance.
- 5) KITO shall not be responsible for any loss or damage caused by transportation, prolonged or improper storage or normal wear and tear of KITO’s Products for loss of operating time.
- 6) This warranty shall not apply to KITO’s Products which have been fitted with or repaired with parts, components or items not supplied or approved by KITO or which have been modified or altered.

THIS WARRANTY IS IN LIEU OF ALL OTHER WARRANTIES. EXPRESS OR IMPLIED, INCLUDING BUT NOT LIMITED TO ANY WARRANTY OF MERCHANTABILITY OR OF FITNESS FOR A PARTICULAR PURPOSE.

KITO

URL:<http://www.kito.ca>

Phone:1-888-322-KITO(Toll free)